

# City of Venice

DEPARTMENTS OF ENGINEERING & UTILITIES



## STANDARD DETAILS, GENERAL NOTES AND TESTING REQUIREMENTS

UPDATED: JAN 2024

### VENICE CITY COUNCIL

Nick Pachota – Mayor  
Jim Boldt – Vice Mayor  
Helen Moore  
Rachel Frank  
Rick Howard  
Joan Farrell  
Ron Smith

### CITY MANAGER

Edward Lavallee

### CITY ENGINEER

Kathleen J. Weeden, P.E.

### UTILITIES DIRECTOR

Javier A. Vargas

# City of Venice

## STANDARD DETAILS, GENERAL NOTES AND TESTING REQUIREMENTS

### TABLE OF CONTENTS

DETAILED DRAWING INDEX.....	<b>2</b>
1 – General Requirements and City Permits .....	<b>4</b>
2 – Contact Personnel .....	<b>5</b>
2.1 City of Venice Staff.....	5
2.2 Florida Department of Health.....	5
2.3 Sarasota County Air and Water Quality .....	6
3 – Construction Plan Submittal Requirements .....	<b>6</b>
3.1 Title Sheet.....	7
3.2 Existing Conditions Plan.....	7
3.3 Approved Site Plan.....	8
3.4 Approved Site Plan and Flood Zone.....	8
3.5 Master Grading & Drainage Plan .....	8
3.6 Master Paving & Striping Plan.....	8
3.7 Master Utility Plan.....	8
3.8 City Standard Details.....	8
3.9 Approved Landscape Plan .....	9
3.10 General Submittal Requirements .....	9
4 – Testing Requirements .....	<b>9</b>
4.1 Roadways.....	9
4.2 Gravity Sewer .....	9
4.3 Storm Sewers .....	11
4.4 Pressure Mains.....	11
4.5 Backflow Assemblies .....	12
5 – Record Drawing Requirements .....	<b>12</b>
6 – Turnover Package Requirements.....	<b>13</b>
7 – GIS / CAD Standards.....	<b>15</b>
7.1 GIS / CAD Scope of Work .....	15
7.2 Acceptable Technology and Accuracy Requirements.....	15
7.3 GIS Standards .....	16
8 – General Stormwater Notes .....	<b>18</b>

# DETAILED DRAWING INDEX

## ENGINEERING

## SHEET NUMBER

SIDEWALK RAMPS AND CURBING	ENG-1
PAVEMENT RESTORATION	ENG-2
TYPICAL ROADWAY SECTION	ENG-3
TYPICAL DRIVEWAY & SIDEWALK	ENG-4
ACCESSIBLE & TYPICAL PARKING SPACE	ENG-5
EMERGENCY VEHICLE ACCESS	ENG-6
SILT FENCE & CONSTRUCTION EXIT	ENG-7
BRICK PAVERS & PERVIOUS CONCRETE	ENG-8
STORM CONFLICT MANHOLE & BOLLARD	ENG-9
BICYCLE MARKINGS	ENG-10

## UTILITIES - GENERAL

## SHEET NUMBER

UTILITY PIPE TRENCH	U-1
AUTOMATIC COMBINATION AIR RELEASE VALVE	U-2
AUTOMATIC COMBINATION AIR RELEASE VALVE (ALTERNATE)	U-2a
TAPPING SLEEVE & VALVE	U-3
VALVE BOX	U-4
UTILITY CONFLICTS & SEPARATIONS	U-5
PIPE FITTINGS & MATERIAL	U-6
RESTRAINED JOINT TABLE	U-7
WATER MAIN ABANDONMENT END RESTRAINT	U-8

## UTILITIES - WATER

## SHEET NUMBER

GATE VALVE	W-1
FIRE HYDRANT ASSEMBLY	W-2
AUTOMATIC FLUSHING DEVICE	W-3
WATER & REUSE METER & BACKFLOW	W-4
BACKFLOW ASSEMBLY (NO MASTER METER)	W-5
RESIDENTIAL WATER & FIRE METER	W-6
REUSE METER & TEMPORARY JUMPER	W-7
RESIDENTIAL METER & SERVICE CONNECTION	W-8
FIRE SERVICE BACKFLOW ASSEMBLY	W-9
FIRE SERVICE INDICATOR POST	W-10

## **UTILITIES - SEWER**

## **SHEET NUMBER**

PLUG VALVE & MANHOLE COVERS	S-1
SANITARY SEWER MANHOLE	S-2
PRECAST SHALLOW MANHOLE	S-3
SEWER SERVICE & CLEANOUT	S-4
SANITARY DROP MANHOLE	S-5
SEWER PIPE TRENCH	S-6

## **UTILITIES – LIFT STATION**

## **SHEET NUMBER**

LIFT STATION SITE LAYOUT	LS-1
LIFT STATION	LS-2
ISOLATION MANHOLE & BOOT DETAILS	LS-3
LIFT STATION SCHEDULE	LS-4
LIFT STATION TELEMETRY	LS-5
CONTROL PANEL FRONT	LS-6
CONTROL PANEL BACK	LS-7
ENCLOSURE & DEADFRONT LAYOUT	LS-8
BACKPLATE LAYOUT	LS-9
TERMINAL STRIP DIAGRAM	LS-10
CONTROL SCHEMATIC DIAGRAM	LS-11
CONTROL PANEL BILL OF MATERIALS	LS-12
UPS PANEL & SPARE PARTS LIST	LS-13
EMERGENCY GENERATOR	LS-14

## Section 1. General Requirements and City Permits

1. These City Standard Details are intended to serve as a current set of guidelines and minimum acceptable standards to City staff. Any deviation from these Details, including, but not limited to, alternative materials, suppliers, or manufacturers may be submitted; but are subject to final approval by the City Engineer.
2. These Details are updated and reissued in January of each calendar year. However, due to unique circumstances, changes or modifications may be required by City staff at any time.
3. These Details are intended to meet all current materials for construction qualifications of FDOT as well as applicable ASTM Standards, latest revisions.
4. All construction within the City of Venice shall meet the applicable testing requirements listed in Section 4.
5. A Maintenance of Traffic (MOT) Plan, if applicable, shall be submitted with the Construction Plans to the City Engineering Department.
6. The City Engineering Department issues the following permits:
  - a) Site Preparation Permit - Before any activity such as removal of vegetation, site grading, delivery of fill, or ground breaking, the property owner or his agent will obtain a Site Preparation Permit from the City. No site activity is to begin until a City-approved BMP Plan is in place. A Site Preparation Permit will be issued by the City upon approval of the BMP Plan. A copy of the City of Venice Tree Permit will be required prior to issuance of the Site Preparation Permit. Contact the City of Venice Building Department to apply for the Tree Permit.
  - b) Construction Permit - The Construction Permit allows for all other site improvements not included within a Site Preparation Permit. Requirements for this permit are discussed in Section 3.
  - c) Right-Of-Way Use Permit - Issued for any construction within the City owned Right-Of-Way. Restoration work in the Public ROW must be completed within 7 days unless written approval is received from the City Engineer or designee to extend the restoration timeframe. Restoration work not completed as required may be referred to Code Enforcement for action including daily fines.
  - d) License Agreement – Issued for any improvement within the City owned Right-of-Way which does not meet the City Standard Details design requirements (i.e. brick paver driveway or structural improvements).

Applications for the above permits are available at the Engineering Department, Forms section of the City Website [www.venicegov.com](http://www.venicegov.com) or at the Building Department counter.

7. A Pre-Construction Meeting shall be held for all Construction Permits prior to start of work. The project Engineer of Record (EOR) or Construction Manager shall coordinate the meeting with the Engineering Department, for the purpose of outlining

City Standards, testing and inspection requirements, City Department responsibilities, and other related construction concerns. The EOR or Construction Manager shall provide copies of all applicable State and Federal permits at this meeting, including SWFWMD ERP, NPDES NOI Letter and SWPPP, FDEP, Health Department and/or FDOT.

8. All Shop Drawings shall be submitted as one complete submittal package only, including a shop drawing schedule which catalogs all the shop drawings for the project. Water, Sewer & Stormwater Shop drawing packages shall include all applicable permits (FDEP & SWFWMD) or a letter from the EOR indicating those permits are not required. Submittals will be rejected prior to review if the permits are not included. Shop Drawings must be approved and stamped by the Engineer of Record (EOR) prior to submission to the City Engineering Department for review. Each sheet of the submittal will be individually stamped and initialed by the EOR. Any construction prior to the review and acceptance process is subject to removal at the Contractor's expense. If approved materials are not available, a letter from the supplier or manufacturer shall be provided. Alternatives shall be approved by the Utilities Department prior to installation.
9. The City of Venice Utilities Department will operate all water valves.
10. Installation of parts must meet all manufacturer's guidelines and requirements.
11. No water may be placed in service until turnover has been accepted by City Council, Sec. 86-232(9)d.

## **Section 2. Contact Personnel**

### **2.1 City of Venice Staff:**

<u>Position</u>	<u>Services Provided</u>	<u>Phone Number</u>
City Engineer	Administration and Final Approval	(941) 882-7409
Assistant City Engineer	Coordination/Assistance with Records	(941) 882-7410
Projects Coordinator	Permits/Turnover Packages	(941) 882-7411
Engineering Technicians	Construction Observation & Inspection Requests	(941) 232-2641 (941) 445-7640
Utilities Director	Final Utilities Approval	(941) 486-2788
Utilities Field Operations	Utilities Inspection, Meters, Services, Backflow Devices	(941) 480-3333
City Arborist	Tree Permits	(941) 882-7433

### **2.2 Florida Department of Health:**

1001 Sarasota Center Blvd  
Sarasota, FL 34240

(941) 861-6133

Construction of any water main or extension of an existing system (Including fire services) is required to submit FDEP Form 62-555.900(7): NOTICE OF INTENT TO USE THE GENERAL PERMIT FOR CONSTRUCTION OF WATER MAIN EXTENSIONS FOR PWSs. Please contact the Department of Health for more information. This form is available at the following web address:

<http://www.dep.state.fl.us/water/drinkingwater/forms.htm>

A CERTIFICATION OF CONSTRUCTION COMPLETION AND REQUEST FOR CLEARANCE TO PLACE PERMITTED PWS COMPONENTS INTO OPERATION (FDEP Form 62-555.900(9)) and reproducible record drawings must be signed, sealed, and submitted by the EOR to FDOH. Please contact the Department of Health for more information.

### **2.3 Sarasota County Air and Water Quality:**

Environmental Protection Division  
1001 Sarasota Center Blvd.  
Sarasota, FL 34240

Construction of any wastewater facility or extension of an existing system is required to submit FDEP Form 62-604.300(8)(a): NOTIFICATION/APPLICATION FOR CONSTRUCTION A DOMESTIC WASTEWATER COLLECTION/TRANSMISSION SYSTEM. Please contact the above address for more information. This form is available at the following web address:

<http://www.dep.state.fl.us/water/wastewater/forms.htm>

Please submit applications to the Engineering Department. Permit applications will not be signed by the Utilities Director until the plans have been approved by the Utilities and Engineering Departments.

A CERTIFICATION OF CONSTRUCTION COMPLETION, REQUEST FOR APPROVAL TO PLACE A DOMESTIC WASTEWATER TRANSMISSION SYSTEM INTO OPERATION (FDEP Form 62-60Y 300(8)(B)) and reproducible record drawings must be signed, sealed, and submitted by the EOR to FDEP. Please contact the above address for more information. Please submit applications to the Engineering Department. Certificate of Construction Completion will not be signed by the Utilities Director until the record drawings have been approved by the Utilities and Engineering Departments.

### **Section 3. Construction Plan Submittal Requirements**

Submit construction plans through the City's Online Permitting system after Planning & Zoning technical review approval. Construction plans will not be accepted for review until permit fee has been paid. Construction plan approval will not be issued until Planning Commission approval is obtained, and all required plan revisions are completed. Construction plans must conform to the Planning Commission's approved Site Plan

and SWFWMD Permit documents. The EOR must provide a signed and sealed engineering report, including lift station calculations (if applicable) demonstrating that the existing wastewater system and proposed wastewater system are able to support the proposed development. A City of Venice Construction Permit and all applicable State and Federal permits are required before beginning any work.

Construction plans shall include, but are not limited to, the following:

### **3.1 Title Sheet:**

- a) Project name, as referenced in Technical Review process or note of discrepancy
- b) Plans shall be titled "Construction Plans"
- c) Location map
- d) Index of sheets
- e) Name of owner and contact information
- f) Name of engineer and contact information
- g) Name of surveyor and contact information
- h) Names of providers of all utilities and services for the property
- i) Designation of public versus private improvements (utilities, roads, etc.)
- j) Date plans issued
- k) Percent and acreage of impervious/pervious area (existing and proposed)
- l) Engineer's quantity estimate of infrastructure improvements
  - Linear feet of reclaimed water main
  - Linear feet of potable water main
  - Linear feet of gravity sewer main
  - Linear feet of force main
  - Number of manholes

#### **Required Notes: (To be shown on Cover Sheet)**

1. All work conducted in the City of Venice Right-of-Way (ROW) will require the issuance of a ROW Use Permit.
2. All work conducted in Sarasota County and/or FDOT ROW shall require a copy of the issued permits.
3. Tree Removal Permit must be obtained from the City of Venice.
4. Post-Development Runoff does not exceed Pre-Development Runoff volume or rate for a 24-hour, 25-year storm event.
5. All Fire Service Backflow Assemblies shall be installed by a certified contractor with a Class I, II, or V Certificate of Competency issued by the State Fire Marshall as per F.S. 633.521
6. Construction site must be posted with 24-hour contact information
7. All utilities, whether public or private, shall meet City of Venice Standards.
8. Contact Public Works Solid Waste Division (941-486-2422) for approval of dumpster location and layout prior to construction

### **3.2 Existing Conditions Plan:**

- a) Boundary and Topographic survey with all existing improvements and easements.
- b) Flood zone designation and limits of the regulatory flood plain.



### **3.3 Approved Site Plan:**

- a) Site Plan must conform to plan approved by Planning Commission.
- b) Site Plan to show plan view of all proposed improvements.

### **3.4 Approved Site Plan and Flood Zone:**

- a) A separate sheet with the approved overall site plan with FEMA flood zone information overlaid.

### **3.5 Master Grading & Drainage Plan:**

- a) Construction Plans must conform to the SWFWMD Stamped, Approved Plans and Permit Conditions.
- b) Individual lot grading plan shall be shown with the proposed finished floor elevation.

### **3.6 Master Paving & Striping Plan:**

### **3.7 Master Utility Plan:**

- a) Profiles shall be shown for all pipelines. Valves and fittings shall be shown and called out. Minimum separation and cover shall be maintained and noted at crossing with other utilities in accordance with these Standard Details.
- b) Proposed Swing Table shall be included in Construction Plan submittal.
- c) Proposed site lighting with utility overlay shall be provided to verify that conflicts do not exist (existing and proposed). Lighting and power equipment shall maintain 5 feet of separation from all utilities and appurtenances.

### **3.8 City of Venice Standard Details (latest version):**

- a) Designation (See Sheet ) shall be provided on applicable sheet for improvements to be constructed in accordance with the COV Standard Details.
- b) All applicable City Standard Details shall be included in the Construction Plan submittal in their entirety, placed onto the EOR's project title block. Details which do not apply to the project may be excluded from the plan set.
- c) These City Standard Details represent the minimum acceptable improvements for projects built within the City and must be signed & sealed by the EOR certifying the details are appropriate for the specific project.
- d) Site conditions of an individual project could warrant an increased design standard from these details. No alteration or modification of the individual City Details is permitted, unless the design professional is increasing the design standard. Any proposed detail changes shall be provided on a separate sheet of the Construction Plan submittal with the revision clearly identified.
- e) Any additional Details provided by EOR must meet or exceed the minimum design standard in the COV Standard Details.
- f) Digital copies of the latest Standard Details may be obtained from the Engineering Department, Forms section of the City website @ [www.venicegov.com](http://www.venicegov.com).

### **3.9 Approved Landscape Plan:**

- a) The approved TRC Landscape Plan shall be included in the Construction Plan set. Landscape Plan shall indicate ALL plants proposed for installation and include a utility overlay to verify that conflicts do not exist.
- b) All landscaping shall maintain 5 feet of separation from all utilities and appurtenances.

### **3.10 General Submittal Requirements:**

- a) North arrows and scales shall be shown on each applicable sheet.
- b) Additional sheets may be necessary to accurately depict the scope of the project or as required by the City Staff for clarity.
- c) Construction Plan size shall be 24"X36" Sheets.
- d) All Right-of-Ways, Easements for drainage, utilities, or other public facilities, which will be relinquished to the City, shall be shown on the respective Master Plan Sheets.
- e) As required by the Florida Board of Professional Engineers, each plan sheet must be signed and sealed by the EOR.
- f) If the development will be phased, all phase lines and sub-phases must be clearly shown on a separate **Phasing Sheet**. Any changes of the phase lines shall be submitted as a Construction Plan Modification for City review and approval.

## **Section 4. Testing Requirements**

The Engineer of Record shall provide testing specifications which are consistent with the following:

### **4.1 Roadways:**

All roadways shall be tested in accordance with the City of Venice Standard Details & FDOT Specifications.

### **4.2 Gravity Sewer:**

- a) Compaction testing
  - Shall be performed on the upstream and downstream side of each manhole/structure.
  - Shall be performed at the mid-point of each run of pipe installed.
  - Shall be performed at 12" lifts, beginning at the springline of the pipe and alternate sides of the pipeline with each lift.
  - Shall be minimum of 98% of maximum compaction under pavement, 95% of maximum compaction under other surfaces as determined by AASHTO Method T-180.
- b) Deflection Testing (Mandrel)
  - Shall be performed in accordance with ASTM D3034, latest revision.
  - Minimum mandrel diameter shall be 7.11" for 8" pipe and 95% of the pipeline interior diameter for any other size pipe.
  - Provide 48 hour advance notification to the City of Venice Engineering Department.

c) Air Test gravity lines and services

- The maximum pressure drop allowable shall be one (1) pound per square inch (PSIG): Refer to Air Test Table below. The minimum initial test pressure shall be three and one half (3 1/2) pounds per square inch (PSIG) except when testing in areas with high water tables. For every foot of groundwater above the springline of the pipe, increase the test pressure by (0.43 PSIG). Maximum test pressure shall be nine (9) PSIG, or not exceeding manufacturer's recommendations. Provide 48-Hour advance notification to the City of Venice Engineering Department.

FROM THE UNI-BELL HANDBOOK OF PVC PIPE  
 SPECIFICATION TIME REQUIRED FOR A 1.0 PRESSURE DROP FOR SIZE AND LENGTH OF PIPE INDICATED.  
 SEE DETAIL 4, NOTE 2c ON SHEET G-1 FOR TEST PRESSURE CALCULATION.  
 THE EOR SHALL PROVIDE TESTING SPECIFICATIONS CONSISTENT WITH THE FOLLOWING TABLE FOR PVC AND DIP:

1 PIPE DIAMETER (INCHES)	2 MINIMUM TIME (MIN:SEC)	3 LENGTH FOR MINIMUM (FEET)	4 TIME FOR LONGER (SECONDS)	SPECIFICATION TIME FOR LENGTH (L) SHOWN (MIN., SEC)								
				100 FT.	150 FT.	200 FT.	250 FT.	300 FT.	350 FT.	400 FT.	450 FT.	
4	3.46	597	0.380	L	3.46	3.46	3.46	3.46	3.46	3.46	3.46	3.46
6	5.40	398	0.854	L	5.40	5.40	5.40	5.40	5.40	5.40	5.42	6.24
8	7.34	298	1.520	L	7.34	7.34	7.34	7.34	7.36	8.52	10.08	11.24
10	9.26	239	2.374	L	9.26	9.26	9.26	9.53	11.52	13.51	15.49	17.48
12	11.20	199	3.418	L	11.20	11.20	11.24	14.15	17.05	19.56	22.47	25.38
15	14.10	159	5.342	L	14.10	14.10	17.48	22.15	26.42	31.09	35.36	40.04
18	17.00	133	7.692	L	17.00	19.13	25.38	32.03	38.27	44.52	51.16	57.41
21	19.50	114	10.470	L	19.50	26.10	34.54	43.37	52.21	61.00	69.48	78.31
24	22.40	99	13.674	L	22.47	34.11	45.34	56.58	68.22	79.46	91.10	102.33
27	25.30	88	17.306	L	28.51	43.16	57.41	72.07	86.32	100.57	115.22	129.48
30	28.20	80	21.366	L	35.37	53.25	71.13	89.02	106.50	124.38	142.26	160.15
33	31.10	72	25.852	L	43.05	64.38	86.10	107.43	129.16	150.43	172.21	193.53
36	34.00	66	30.768	L	51.17	76.55	102.34	128.12	153.50	179.29	205.07	230.46
a.) FOR PIPE LENGTHS GREATER THAN FOUR HUNDRED FIFTY (450) FEET BUT LESS THAN LENGTH IN COLUMN 3, USE MINIMUM TIME IN COLUMN 2.				EXAMPLE: DETERMINE TEST TIME FOR 425 FEET OF TWELVE (12) INCH PVC.								
b.) FOR PIPE LENGTHS GREATER THAN FOUR HUNDRED FIFTY FEET AND GREATER THAN LENGTH IN COLUMN 3, SUBTRACT LENGTH OF COLUMN 3 FROM ACTUAL PIPE LENGTH, THEN MULTIPLY DIFFERENCE BY TIME IN COLUMN 4 AND ADD TO TIME IN COLUMN 2.				CONVERT min:sec TO SECONDS (min. X 60) + sec: 400 = 360 s; 450=480s INTERPOLATE 425 = 363s + (408 - 363) X (425 - 400) T425 386s (450 - 400)								
NOTE: INTERPOLATE BETWEEN VALUES ON TABLE AS SHOWN IN EXAMPLE FOR AIR TEST.				CONVERT SECONDS TO min:sec (386 sec/60) = 6.43 min. 6.43 min. = 6 min. + (60 X 0.43) 425 = 6 min. 26 sec. NOTE: FOR LENGTHS GREATER THAN FIVE HUNDRED (500) FEET CONTACT THE EOR.								

d) Television Inspection

- Contractor shall provide pdf of PACP reports of sanitary sewer testing for each gravity sewer segment for City review prior to record drawing approval.
- Upon construction completion, any deflection causing a depth of water greater than 1/2" is unacceptable and must be repaired or replaced. The Owner shall provide an .mpg file of the television inspection for all gravity sewer piping being turned over to the City prior to acceptance of improvements.
- At time of one-year warranty inspection, any deflection causing a depth of water greater than 1" is unacceptable and must be repaired or replaced. The

Owner shall provide an .mpg file of the television inspection for all gravity sewer piping turned over to the City prior to City release of the maintenance bond. The owner must perform a smoke test of the system turned over to the City. The Utilities Department must witness the smoke test and the EOR provide a written report.

- Gravity sewer flow shall be maintained throughout the warranty period and the sewer system free of inflow and infiltration. At time of one-year warranty inspection, CCTV inspection reports shall be provided showing the sanitary sewer to be clean, clear, and free of leaks or defects. Any issues shall be rectified by the Contractor prior to release of bond.

#### **4.3 Storm Sewers:**

- a) Storm Sewers shall be tested as per FDOT Specifications and include compaction testing in conformance with Item 4.2.a above, Gravity Sewer Compaction Testing.
- b) The Owner shall provide a video tape of the camera inspection for all drainage piping being turned over to the City prior to acceptance of the improvements. Video inspection shall be conducted within one year and shall be completed when the ground water is at or above normal elevation.

#### **4.4 Pressure Mains (Potable, Reclaimed, Force Mains):**

- a) Compaction testing shall be performed every 250 feet.
- b) Pressure Test (Main)
  - Prior to testing, all air must be expelled from the pressure main.
  - Test pressure shall be: Water (Potable & Reclaimed) Mains: 150 PSI  
Force (Wastewater) Mains: 100 PSI
  - Test pressure shall be held for a minimum of 2 hours
  - Allowable leakage shall be calculated with the following:  
$$L = S D \sqrt{P} / 148,000$$

L= Allowable leakage, GPH  
S= Length of pipe tested, FT  
D= Diameter of pipe, IN  
P= Average test pressure, PSI
- c) Contact the Building Department for Fire Service testing requirements and scheduling.
- d) Pressure Test (Tapping sleeve & valve) shall be in conformance with these Standards.
- e) Bacteriologic testing of Potable Mains shall be coordinated through COV Engineering Dept. and in conformance with State of Florida Department of Health. Bacterial sample shall be taken by FDOH personnel only.
- f) For all water needed for flushing, pressure testing or bacteriological sampling, please provide 48 hours advance notice to the City of Venice Utilities Department (941) 480-3333. The City will operate all valves.
- g) Disinfecting of water mains must follow ANSI/AWWA 651-99 and must be witnessed by City Utilities. 48-Hr. (480-3333). Disinfection plan to be submitted to COV Utilities Dept. for review & approval prior to scheduling disinfection.
- h) Force Mains shall be a minimum of 4" in diameter.

- i) There shall be no lead products used in any Potable Water infrastructure including pipes, fittings or joints.
- j) All taps and pressure tests shall be coordinated by the Engineering Dept.
- k) A continuity test shall be performed on all tracer wires and a report shall be provided with the turnover documentation.

#### **4.5 Backflow Assemblies:**

- a) Backflow Assemblies shall be tested upon installation In accordance with the City's Cross Connection Control Program Manual. Results shall be submitted to the Utilities Department within 72 hours.
- b) Current Backflow testing certification shall be performed and provided within 90 days of Certificate of Occupancy or transfer of ownership from Developer, whichever comes first.

### **Section 5. Record Drawing Requirements**

- 1.) Record Drawings shall be in the same format as the approved Construction Drawings (Plan and Profile). The Record Drawings shall be developed, signed, and sealed by the EOR. Record Drawings shall be fully reviewed by the EOR and in final form prior to submission. In order to verify conformance with the approved Construction Plans, this certified information shall be provided to the EOR by a Professional Surveyor & Mapper (PSM) licensed in the State of Florida. Water and Sewer Certifications of Completion will not be signed by Utilities Director until Record Drawings are approved. Record Drawings will not be reviewed until the first lift of asphalt has been installed over all applicable utilities.
- 2.) As a minimum, the Record Drawings shall consist of the following:
  - a) Accurate dimension shall be provided for all improvements to be turned over to the City upon construction completion. Typically, this includes pipes, valves, manholes, lift stations, roadways, signage, sidewalks, swales, stormwater facilities, etc.
  - b) A minimum of two (2) swing ties shall be provided for each valve, fitting, and other underground appurtenances and shown in table format. Swing tie locations shall be separate and not along the same line. If distance to swing tie pt. (manhole, curb inlet, etc.) is more than 200', a brass disc (see valve box Detail) may be set in curb with designation "ST#." Proposed Swing Tie Table shall be included with Construction Plans.
  - c) Top of pipe elevations and finish grade elevations shall be provided at a maximum of 100 foot intervals.
  - d) Easements, Right-of-Ways and property lines shall be correctly shown and consistent with any recorded plats. If a Blanket Easement has been granted, place appropriate Note on each pertinent Plan Sheet.
  - e) City Standard Details matching the detail in effect at time of construction.
- 3.) Record Drawing Submittal Procedure:

- a) Submit three (3) Signed & Sealed copies and USB Flash Drive with electronic files to the City Engineer's office labeled as Record Drawings for review and approval by the City. Field verification of said improvements. All spare parts shall be delivered to the City of Venice prior to Record Drawing review.
- b) Submit, in electronic format, approved construction plans in PDF and GIS Data Shape all files necessary to update our Utility Database and to print/plot the Record Drawings. These electronic files shall conform to the requirements in Section 7. A report on the continuity test for the tracer wire shall be provided. The City shall not sign off on DOH or FDEP water and wastewater permits to place the facilities into operation until the Record Drawings are approved and the electronic PDF and GIS files have been provided and accepted. Once all these required items are complete, the utility turnover will be placed on the City Council agenda for approval if applicable.
- c) The EOR (Engineer of Record) shall submit SWFWMD Stormwater Record Drawings and copy of the form - STATEMENT OF COMPLETION AND REQUEST TO TRANSFER TO OPERATION ENTITY, to the City Engineer's office.
- d) A copy of all testing required in Section 4.
- e) A Final Certificate of Occupancy (CO) shall not be granted if the above Record Drawing submittal requirements have not been met and all agency permits have been closed out and provided to the City.

## **Section 6. Turnover Package Requirements**

Upon construction completion, portions of the project that will be maintained by the City must be 'Turned Over' to the City. City acceptance of improvements, such as water, reclaimed water, sewer, stormwater systems and roadways, require that all improvements be constructed in accordance with the latest version of the City Standard Details, be certified complete by the appropriate regulatory authority, submittal of all required Turnover Package documentation and formal acceptance by the Venice City Council via an Adopted Resolution. A copy of the turnover package requirements can be found at [Venicegov.com](http://Venicegov.com) or by contacting the Engineering Dept. at 941-882-7411. A Final Certificate of Occupancy or placing water, reclaimed water or sewer into service will not be authorized until the process is complete including formal acceptance by the City Council and clearance by the regulatory authority.

The City is required to have the Plat reviewed for conformity with FL Statutes by a Professional Surveyor and Mapper contracted or employed by the City and registered under Chapter 472 F.A.C. Costs shall be borne by the legal entity offering the Plat for recording. A minimum of four (4) weeks is necessary before any Plat can be sent to City Council for approval.

All completed Turnover Package documentation must be submitted to the City Engineering Department a minimum of **three (3) weeks** prior to the City Council meeting. City Council meetings are normally the 2nd and 4th Tuesday of the month; therefore, the deadline for submittal of complete Turnover Packages is 4 P.M. on the TUESDAY three (3) weeks prior to the City Council meeting. A copy of the City Council calendar is

available on-line at [www.venicegov.com](http://www.venicegov.com).

A Complete Turnover Package includes all of the following items if applicable to the project:

- a) Bill of Sale for the lines, and/or systems
- b) Affidavit of No Liens
- c) Certification of Contributions in Aid of Construction
- d) Final Cost Letter & Cost Breakdown worksheet (verification of final costs S/S by EOR)
- e) Legal Description including sketch if easement is being granted.
- f) Copy of Plat (if new Subdivision, or if existing is re-divided)
- g) Contractual Guarantees from Owner
- h) Easements granting right of access to lines and/or systems within private property
- i) A Maintenance Bond in the amount of at least 15% of the cost of construction of the improvements to be turned over, secured by an Irrevocable Letter of Credit or Bond from an approved surety company, or cash, whereby the principal agrees to perform any required maintenance or testing for a period of one year from the date of acceptance by the City.
- j) Declaration of Maintenance Responsibilities
- k) Signed and sealed final record drawings approved by the City of Venice Engineering and Utilities Departments. (Please see above for the record drawing requirements and submittal procedure).
  - Record drawings must be approved by the Engineering and Utilities Departments prior to processing Completion Certifications for Sarasota County Air and Water Quality or DOH. An incomplete Turnover Package will not be placed on the Council Agenda for the next scheduled meeting.
  - In order to expedite the record drawing and turnover process, please verify that record drawings are accurate at first submittal. Record drawings must be reviewed by the Engineering and Utilities Departments each time revised drawings are submitted. Turnover Packages will not be considered complete until signed and sealed copies of the record drawings approved by the Engineering and Utilities Departments are submitted and all turnover documents have been completed including required bonds

These requirements are based on Resolution 853-84, approved and adopted by the City Council on November 27, 1984.

A Turnover Package, including instructions and required forms, is available for pick-up, regular mail or via email from the City Engineering Department.

At time of one-year warranty inspection, all systems must be operational. City staff may require property owner to conduct verification testing if necessary to determine condition of improvements. Typically this includes, but is not limited to, the following:

- Valves
- Fire Hydrants
- Backflow Assembly

- Lift Station
- Gravity collection pipes
- Force Mains
- Water Lines
- Manholes
- Roadway condition
- Storm Sewers
- Smoke Testing of Wastewater System
- CCTV of Sanitary Sewer

## **Section 7. GIS / CAD Standards**

### **7.1 GIS / CAD SCOPE OF WORK:**

- 1.) The CITY OF VENICE (COV) has adopted Geographic Information System (GIS) technologies to store, manage, and maintain geographic/spatially-related data. Likewise, the majority of the civil engineering community has evolved to the point where the predominating design environment is Computer-Aided Design. The purpose of this section is to set a basic GIS standard to ensure consistent electronic deliverables. These standards and procedures are for integration of digital engineering CAD drawings and attribute data into the GIS database environments, while maintaining the integrity and positional accuracy of the data. The Engineer of Record shall also submit digital CAD drawings in a GIS file geodatabase format.
- 2.) It is important that the consultant read over the entire standard details document to become as familiar with the requirements as possible, and shall be the first source of reference when questions arise.
- 3.) Upon review of the GIS digital or CAD submittals, the COV shall contact the consultant to discuss problems or omissions in the digital data submission to ensure compliance of these standards.

### **7.2 ACCEPTABLE TECHNOLOGY AND ACCURACY REQUIREMENTS:**

- 1.) GPS units used to collect data must be accurate to sub-foot when differentially corrected and shall depict actual horizontal and vertical locations of utility assets such as: manholes, system valves, hydrants, blow-off valves, air release valves, master meters, and the pump station wet well. Also, the locations at the intersection of water, wastewater and reclaimed water pressure piping, as well as at 100 feet intervals along the pipeline. A surveyor shall certify the state plane coordinates, provide the coordinates on the AS-BUILT DRAWINGS, and provide the coordinate attribute table in an electronic database to the Engineer of Record for final submittal. GPS units that do not meet this standard will not be acceptable (Note: Recreational GPS receivers do not comply with these standards).



### 7.3 GIS STANDARDS:

- 1.) Only drawings relevant to the project's phase of submittal shall be included. For example, do not include "Bid Set" or "Proposed" drawings in the submitted "RECORD DRAWING" submittals. Also, do not include drawings or documents that would not normally be included in the set of printed drawings, except for base drawings or drawings to be externally referenced. City Standard Details for constructed utility improvements shall be included in the Record Drawings.
- 2.) Features will be horizontally projected in NAD83 HARN State Plane Florida West and vertically projected in NAVD88.
- 3.) Data will be sent as ESRI file formats (geodatabase (preferred), shapefiles, or an ESRI map package (.mpk) with all layers included.)
- 4.) All data will be topologically accurate. Valves, hydrants, fittings, etc. must be on the appropriate main. Pipe features will be split at valves, tees, or manholes. Main features must connect at endpoints. Services must start on the appropriate main.
- 5.) Submissions will include all infrastructure that is being installed or modified as part of the project and only those features.
- 6.) Each feature type will have its own layer. Mains and other pipes will be represented as line features. All other features will be represented as points on the appropriate line feature (use center of feature for point location). The following layers shall be included for each type of utility constructed (Potable, Wastewater, Raw, Fire, Reclaimed, Stormwater.)
  - a) Pressurized Main
  - b) Service Lines
  - c) Isolation Valves
  - d) Control Valves
  - e) Hydrants
  - f) Fittings
  - g) Water Meters/Backflow Prevention Devices
  - h) Gravity Mains
  - i) Manholes
  - j) Sewer Cleanouts
  - k) Lift Stations
  - l) Stormwater Only
    - i. Junction Structures (manhole, junction box, pipe to pipe)
    - ii. Network Structures
    - iii. Control Valves
    - iv. Drop Structures

- v. Outfalls
- vi. Weirs

7.) The following information shall be included for all new features:

- a) Ownership (City, County, Private)
- b) Tracer Wire (Yes/No)
- c) Year of Install
- d) Project Name

8.) The following information will be included for all pipes:

- a) Water Type (Potable, Wastewater, Reclaim, Raw, Stormwater)
- b) Pipe Diameter (inches)
- c) Pipe Material (PVC, HDPE, DIP, etc.)
- d) Pipe Class/Diameter Ratio (SDR 26, DR 18, etc.)
- e) Average depth (Ground Elevation to TOP)
  - i. A point feature of top of pipe (TOP) measurements with this information is acceptable in addition to this field.

9.) The following information will also be included for gravity sewer mains:

- a) Calculated Slope (%)

10.) The following information will be included for all valves:

- a) Water Type (Potable, Wastewater, Reclaim, Raw, Fire)
- b) Valve Type (Gate, Ball, ARV, Autoflusher, etc.)
- c) Nominal Valve Size (inches)
- d) Turns to Close
- e) Make/Manufacturer
- f) Ground Elevation
- g) Top of Pipe Elevation

11.) The following information will be included for all hydrants:

- a) Water Type (Potable, Reclaimed)
- b) Make/Manufacturer
- c) Ground Elevation
- d) Top of Pipe Elevation
- e) Bury Depth
- f) Distance to Hydrant Valve

12.) The following information will be included for all manholes:

- a) Manhole Diameter (inches)
  - b) Rim Elevation
  - c) Invert Elevations - Include separate fields for each direction.
  - d) Lined (True/False)
  - e) Liner type (HDPE/Agro, Epoxy, Raven)
  - f) Calculated Depth based on Rim and Lowest Invert (decimal feet)
- 13.) The following information will be included for all fittings:
- a) Fitting Type (Tee, Bend (angle), Adapter, etc.)
  - b) Size (inches)
  - c) Ground Elevation
  - d) Top of Pipe Elevation

A blank geodatabase is available on the City website to facilitate data entry. Exemptions to the GIS requirements for small projects may only be made at the discretion of the Utilities Director.

## **Section 8. Stormwater General Notes**

- 1) All stormwater structures shall be bedded on 6" Min. compacted gravel or crushed stone.
- 2) Stormwater pipes installed below the water table, within wet conditions will require 6" Min. compacted gravel or crushed stone bedding.
- 3) All stormwater pipes and structures within public trafficable areas shall be reinforced concrete unless otherwise approved by the City Engineer.
- 4) Stormwater pipes within private property may be smooth walled HDPE, Polypropylene, or A-2000 PVC with watertight connections and sufficient cover as calculated by the EOR. Roof drainage pipe may be C900 DR-25 PVC white color or blue color with white tape. Note that structures will need to be placed at changes in grades or elevations as well as changes of directions (elbows and tee's cannot be used).
- 5) No lifting holes or other similar penetrations of stormwater piping permitted. All piping joints shall be wrapped with a Mirafi Filter Fabric or equal.
- 6) All pipe joints will be gasketed according to the manufacturer, FDOT and ASTM Standards to provide a leak proof connection
- 7) All pre-cast structures shall meet FDOT and ASTM C-478 Standards.
- 8) Inlet gratings in areas accessible to bicycle or to pedestrian use must be reticuline or of similar manufacture.
- 9) Inlet gratings in corrosive areas shall be galvanized.

- 10) Stormwater inlets should be designed to reject debris, trash, and other pollutants from entering into public stormwater conveyances.
- 11) Outfalls into the surface waters should be designed with devices to reduce the discharge of foreign materials.

# **ENGINEERING DETAILS**

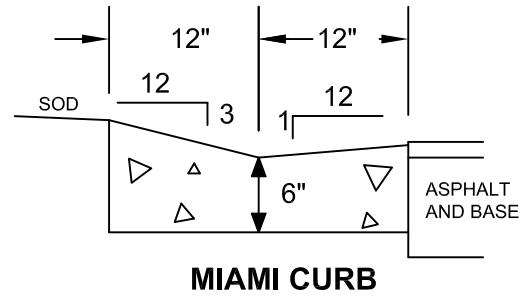
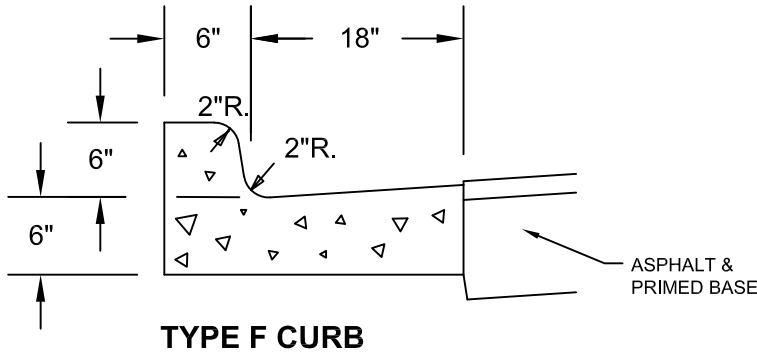

- 1.) ALL STREETS SHALL HAVE A TWO-FOOT WIDE CONCRETE (3000 PSI AT 28 DAYS WITH FIBER REINFORCEMENT) CURB AND GUTTER, AND MEET OR EXCEED FDOT SPECIFICATIONS UNLESS OTHERWISE APPROVED BY THE CITY ENGINEER.

## CURB DETAIL

N.T.S.

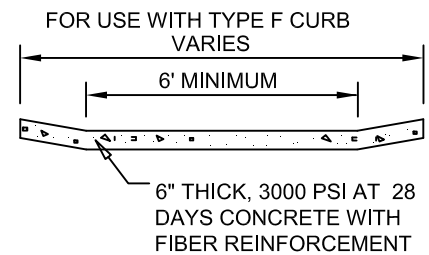
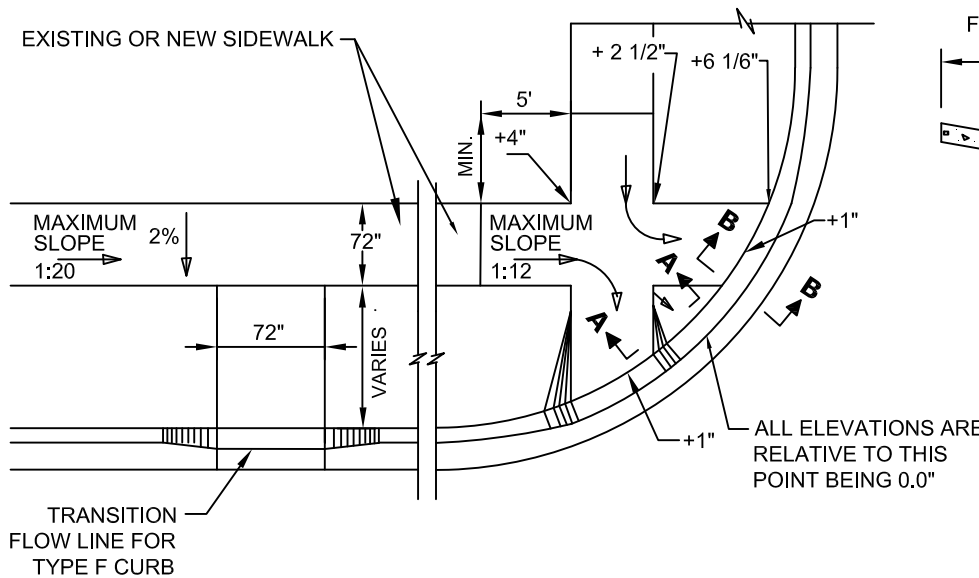

**(SECTION A-A)**  
N.T.S.

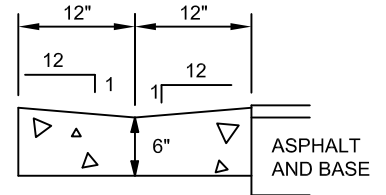

**(SECTION B-B)**  
N.T.S.

- 1.) ALL CONCRETE RAMPS SHALL BE 4" THICK, INCREASING TO 6" THICK WITHIN 48" OF THE CURB
- 2.) ALL CONNECTIONS TO AN EXISTING SIDEWALK SHALL BE AT AN EXPANSION OR CONTRACTION JOINT
- 3.) THE MAXIMUM RAMP SLOPE SHALL BE 1:12, FOR A VERTICAL DISTANCE OF NOT MORE THAN 6 INCHES.
- 4.) THE MAXIMUM RUNNING SIDEWALK SLOPE SHALL BE 1:20, AND MAXIMUM CROSS SLOPE SHALL BE 2%.
- 5.) ALL SIDEWALK RAMPS AND STREET CONNECTIONS WITHIN THE PUBLIC ROW SHALL HAVE A TACTILE SURFACE.
- 6.) TACTILE SURFACES SHALL MEET THE MOST CURRENT AMERICANS WITH DISABILITIES ACT STANDARDS, BE FDOT COMPLIANT AND SHALL BE BRICK RED IN COLOR.
- 7.) ALL MATERIALS & METHODS OF CONSTRUCTION SHALL BE IN ACCORDANCE WITH LATEST EDITION OF THE FDOT, "STANDARDS FOR ROAD & BRIDGE CONSTRUCTION". IN ADDITION, CONCRETE SHALL BE 3000 PSI AT 28 DAYS WITH A MAXIMUM 4" SLUMP AND FIBER REINFORCEMENT.

## SIDEWALK RAMP DETAIL

N.T.S.

**CITY OF VENICE** 401 W VENICE AVE  
VENICE, FL 34285  
ENGINEERING DEPARTMENT (941) 486-2626



**ENGINEERING**

**SIDEWALK RAMPS  
& CURBING**

DATE  
JAN 2024

SHEET NO.  
**ENG-1**

## PLAN VIEW

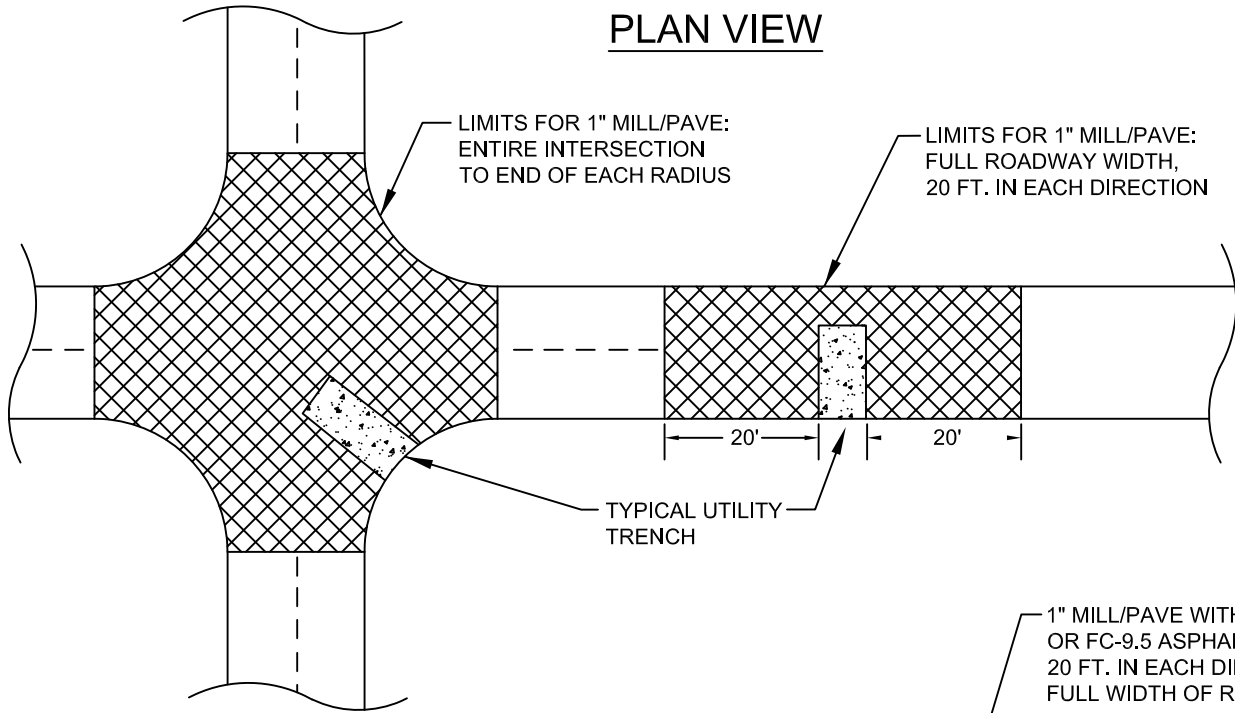

1" MILL/PAVE WITH SP-9.5  
OR FC-9.5 ASPHALT  
20 FT. IN EACH DIRECTION  
FULL WIDTH OF ROADWAY

BASE REPAIR SHALL  
BE 5" OF B-12.5  
ASPHALT OR 10" CCA

C/L PIPE

1" MILL/PAVE WITH SP-9.5  
OR FC-9.5 ASPHALT  
20 FT. IN EACH DIRECTION  
FULL WIDTH OF ROADWAY

1" SP-9.5 ASPHALT WITHIN  
LIMITS OF TRENCH

EXISTING  
PAVEMENT

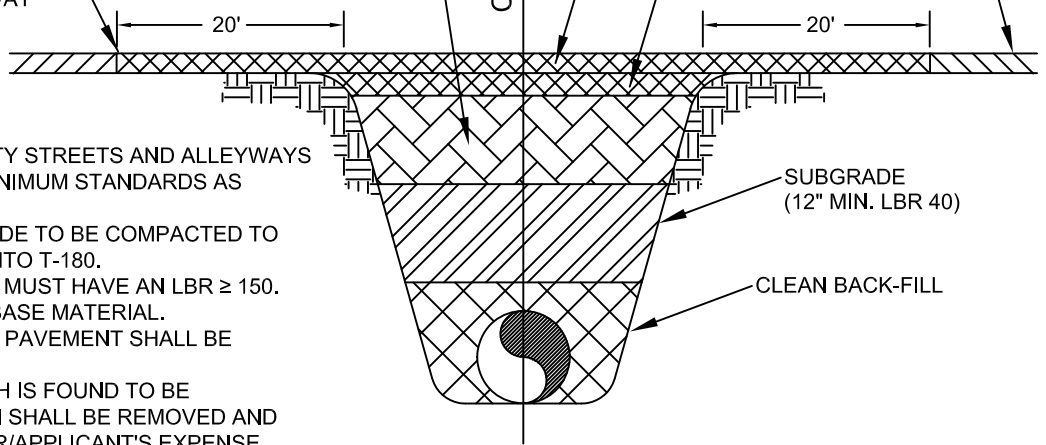

## TRENCH VIEW

- 1.) ALL PAVEMENT CUTS WITHIN CITY STREETS AND ALLEYS SHALL BE RESTORED TO THE MINIMUM STANDARDS AS SHOWN IN THIS DETAILS.
- 2.) TRENCH BACKFILL AND SUBGRADE TO BE COMPACTED TO 98% OF MAX. DENSITY PER AASHTO T-180. CRUSH CONCRETE AGGREGATE MUST HAVE AN LBR  $\geq$  150. SHELL IS NOT AN ACCEPTABLE BASE MATERIAL.
- 3.) ALL CONNECTIONS TO EXISTING PAVEMENT SHALL BE STRAIGHT AND FLUSH.
- 4.) ANY RESTORATION WORK WHICH IS FOUND TO BE UNSATISFACTORY IN CONDITION SHALL BE REMOVED AND REPLACED AT THE CONTRACTOR/APPLICANT'S EXPENSE.
- 5.) RESTORATION WORK IN THE PUBLIC ROW MUST BE COMPLETED WITHIN 7 DAYS UNLESS WRITTEN APPROVAL IS RECEIVED BY THE CITY ENGINEER OR DESIGNEE TO EXTEND THE RESTORATION TIMEFRAME. RESTORATION WORK NOT COMPLETED AS REQUIRED MAY BE REFERRED TO CODE ENFORCEMENT FOR ACTION INCLUDING DAILY FINES.

# PAVEMENT RESTORATION DETAIL

N.T.S.

**CITY OF VENICE** 401 W VENICE AVE  
VENICE, FL 34285  
ENGINEERING DEPARTMENT (941) 486-2626



**ENGINEERING**

**PAVEMENT  
RESTORATION**

DATE  
JAN 2024

SHEET NO.  
**ENG-2**

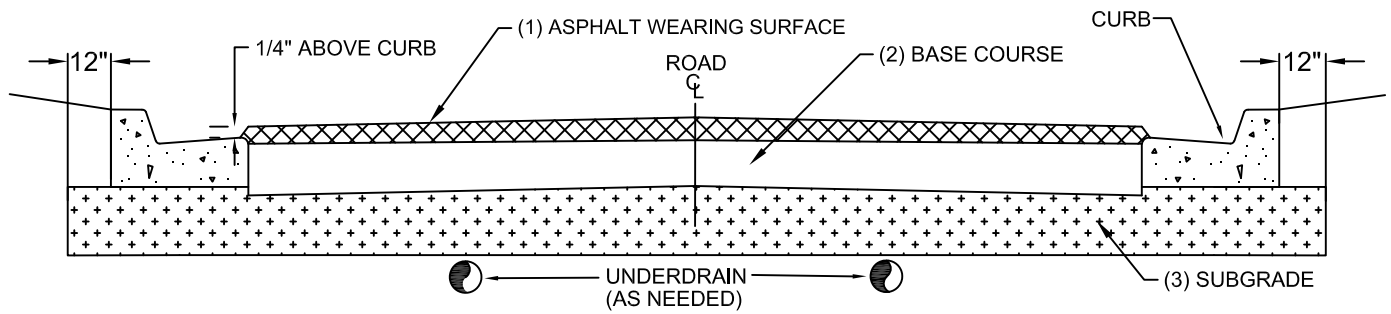

**ROADWAY SECTION DESIGN (MINIMUM THICKNESS)**

STREET CLASSIFICATION	(1) ASPHALT SURFACE:	(2) BASE:			(3) SUB-GRADE: TYPE B STAB.
		B-12.5	CTB	CCA	
PRIVATE ACCESSWAY & LIGHT DUTY PARKING	2" TYPE SP-9.5 (INSTALLED AS TWO 1" LIFTS)	4"	8"	8"	8" MIN 40 LBR
RESIDENTIAL STREET	2" TYPE SP-9.5 (INSTALLED AS TWO 1" LIFTS)	5"	10"	10"	12" MIN 40 LBR
INDUSTRIAL STREET (PUBLIC/PRIVATE)	2" TYPE SP-12.5 & 1" TYPE FC-9.5	5"	10"	10"	12" MIN 40 LBR
COLLECTOR / ARTERIAL STREET	3" TYPE SP-12.5 & 1" TYPE FC-9.5	5"	10"	10"	12" MIN 40 LBR

- 1.) ALL STREETS WITHIN THE CITY LIMITS SHALL MEET THE MINIMUM DESIGN STANDARDS AS ESTABLISHED IN THIS DETAIL.
- 2.) ALL INSTALLATION METHODS AND MATERIALS SHALL CONFORM WITH THE LATEST EDITION OF THE FDOT STANDARD SPECIFICATIONS FOR ROAD AND BRIDGE CONSTRUCTION.
- 3.) CRUSHED CONCRETE AGGREGATE (CCA) MUST HAVE AN LBR ≥150. SHELL IS NOT AN ACCEPTABLE BASE MATERIAL.
- 4.) CEMENT TREATED BASE:
  - a.) THE MATERIAL TO BE USED AS THE FILLER AGGREGATE IN CTB MUST BE LBR TESTED PRIOR TO DESIGN FORMULATION (ADDING CEMENT). THIS MATERIAL MUST ACHIEVE AN LBR VALUE OF ≥ 100.
  - b.) CTB DESIGN CRITERION SHOULD TARGET RANGE FROM 175 TO 275 PSI ON 7 DAY BREAK. TESTING MUST BE PROVIDED TO VERIFY THE COMPRESSIVE STRENGTH OF THE MIX.
- 5.) ALL GRANULAR COURSES OF ROAD CONSTRUCTION MUST BE COMPACTED TO 98% OF ITS OPTIMUM DENSITY AS PER T-180 (AASHTO). CTB SHALL BE COMPACTED TO 98% OF ITS LAB FORMULATION DENSITY (AASHTO T-99).
- 6.) ALL MINERAL MATERIALS USED IN CONSTRUCTION OF ROADWAYS MUST MEET THE FOLLOWING CRITERIA:
  - a.) FINES (PASSING # 200 SIEVE) MUST BE LIMITED TO ≤ 12%, ORGANICS LIMITED TO ≤ 5%, NO DELETERIOUS MATERIALS.
- 7.) SIGNAGE AND PAVEMENT MARKINGS SHALL BE IN ACCORDANCE WITH LATEST EDITION OF THE FDOT ROADWAY AND TRAFFIC DESIGN STANDARDS AND THE MANUAL ON UNIFORM TRAFFIC CONTROL DEVICES (MUTCD MANUAL).
- 8.) ALL CITY STREET SIGNS WILL BE BLUE BACKGROUND WITH 6" WHITE LETTERS AND CONSTRUCTED WITH HIGH INTENSITY REFLECTORIZED MATERIAL. ALL STREET SIGNS SHALL BE 9 INCHES WIDE AND APPROVED BY THE DIRECTOR OF PUBLIC WORKS PRIOR TO INSTALLATION.
- 9.) ALL CURB PADS SHALL MEET THE SAME STRUCTURAL AND COMPACTION STANDARDS AS ROAD SUB GRADE. THESE PADS WILL EXTEND TO AT LEAST 12" BEYOND THE CURB.
- 10.) UNDERDRAINS OR SIDEDRAINS MAY BE INCLUDED WHEN THE GROUND WATER LEVELS MAY AFFECT THE STRUCTURAL INTEGRITY OF THE ROAD. THIS DESIGN SHALL BE THE RESPONSIBILITY OF ENGINEER OF RECORD.
- 11.) ANY PROPOSED TRAFFIC CALMING DEVICES MUST BE APPROVED BY THE CITY ENGINEER & FIRE CHIEF.
- 12.) ASPHALT COURSES AND CONCRETE SHALL NOT BE PLACED WHILE RAIN IS FALLING, OR WHEN THERE IS STANDING WATER ON THE SURFACE TO BE COVERED.
- 13.) TACK COAT SHALL BE APPLIED BETWEEN ALL ASPHALT LAYERS.

**TYPICAL ROADWAY SECTION**

N.T.S.

**CITY OF VENICE** 401 W VENICE AVE  
VENICE, FL 34285  
ENGINEERING DEPARTMENT (941) 486-2626



**ENGINEERING**

**TYPICAL ROADWAY SECTION**

DATE  
JAN 2024

SHEET NO.  
**ENG-3**



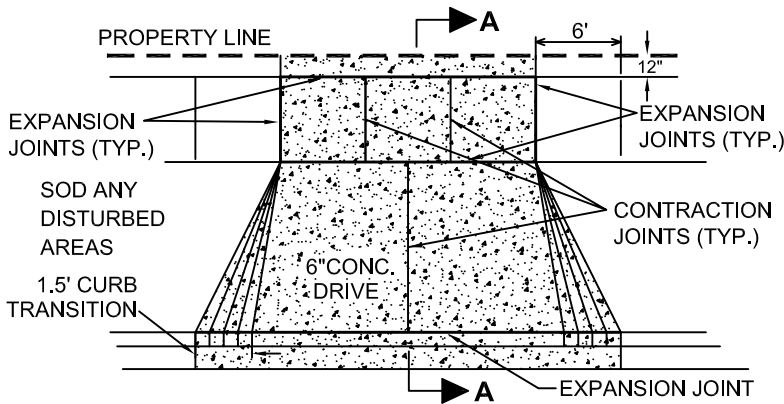

**RESIDENTIAL DRIVEWAY**

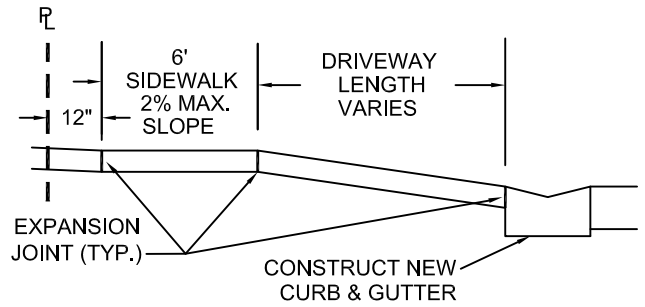

**SECTION A-A**

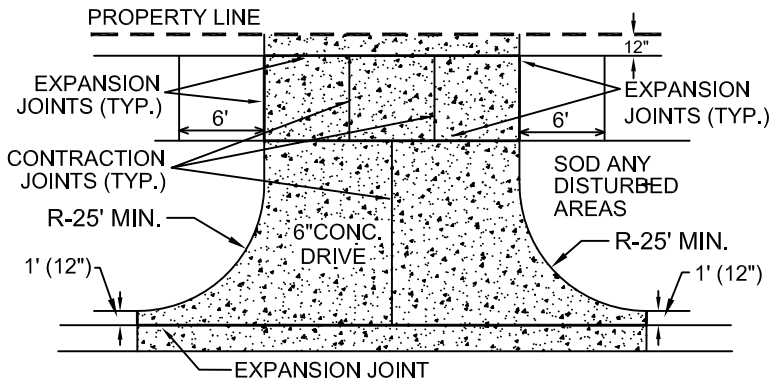

**COMMERCIAL/ INDUSTRIAL/ MULTI-FAMILY**

- 1.) SIDEWALKS AND DRIVEWAYS SHALL BE CONSTRUCTED OF 3000 PSI AT 28 DAYS CONCRETE (MAXIMUM 4" SLUMP) WITH FIBER REINFORCEMENT.
- 2.) ALL SIDEWALKS SHALL BE 6' WIDE AND CONSTRUCTED WITH A MAX. CROSS SLOPE OF 2% AND MAX. RUNNING SLOPE OF 5%.
- 3.) CONTRACTION SAW-CUTS SHALL BE CONSTRUCTED EVERY 6' LENGTH OF SIDEWALK. EXPANSION JOINTS SHALL BE CONSTRUCTED AT 60' INTERVALS.
- 4.) 1/2-INCH THICK ASPHALTIC FELT OR "PRESSURE TREATED WOOD" SHALL BE PLACED AT EACH EXPANSION JOINT.
- 5.) EXISTING CURB AND GUTTER SHALL BE REMOVED ONLY AT EXISTING JOINTS.
- 6.) DRIVEWAY WIDTH AND LOCATION SHALL COMPLY WITH ZONING CODES.
- 7.) DRIVEWAY SLOPES SHALL BE IN ACCORDANCE WITH THE LATEST EDITION OF THE FDOT, "ROADWAY AND TRAFFIC DESIGN STANDARDS", INDEX 515.
- 8.) RESIDENTIAL DRIVEWAYS SHALL BE CONSTRUCTED WITH CONCRETE UNLESS OTHERWISE APPROVED BY THE CITY ENGINEER.

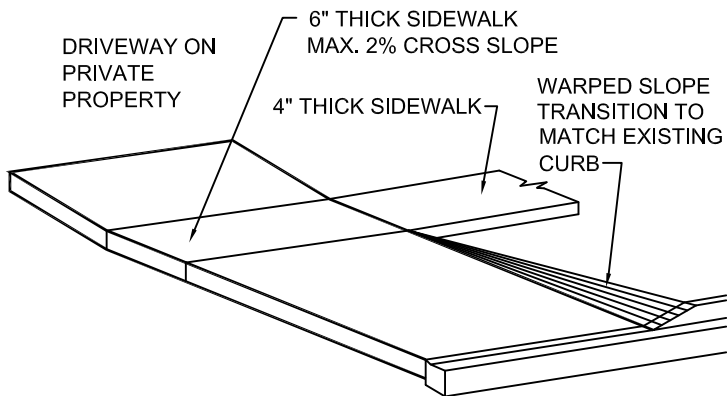

**6" CONCRETE RESIDENTIAL DRIVEWAY**

**DRIVEWAY & SIDEWALK DETAIL**

N.T.S.

**CITY OF VENICE**  
ENGINEERING DEPARTMENT

401 W VENICE AVE  
VENICE, FL 34285  
(941) 486-2626

**ENGINEERING**

**TYPICAL DRIVEWAY  
& SIDEWALK**

DATE  
JAN 2024

SHEET NO.  
**ENG-4**



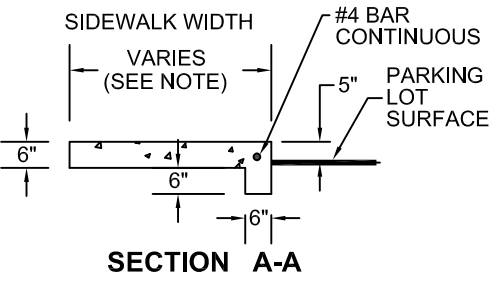
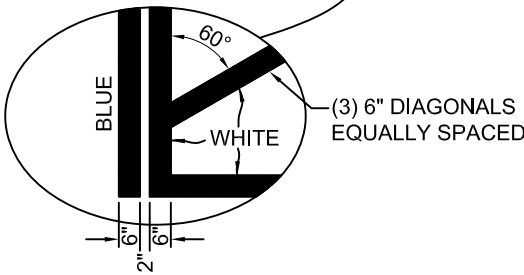
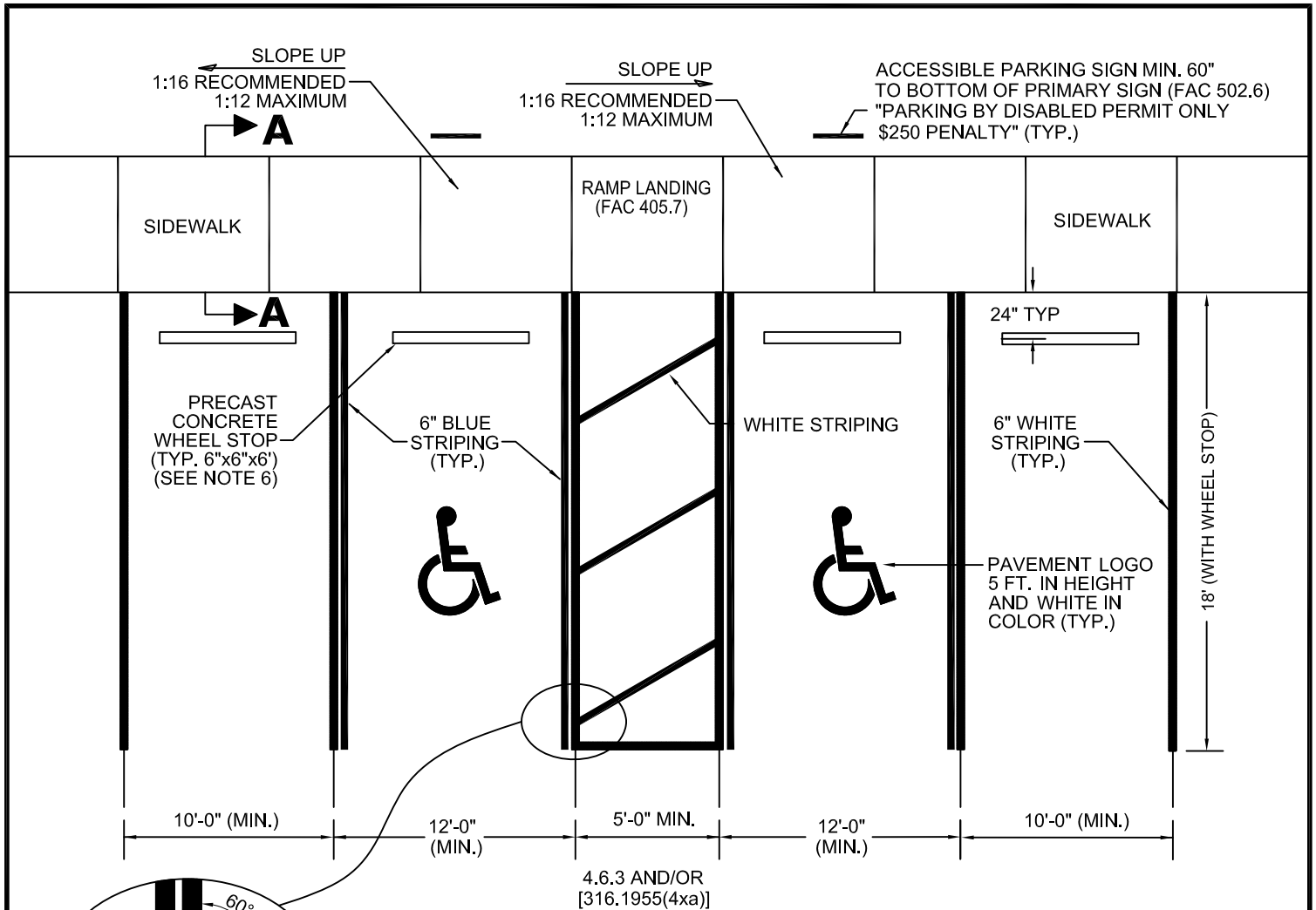

- 1.) IF AN ADJACENT SIDEWALK IS A MINIMUM OF SEVEN (7) FEET IN WIDTH AND PROVIDES A 5" INCH CURB, THE SIDEWALK MAY SERVE AS THE WHEEL STOP AND THE STANDARD PARKING SPACE MAY BE 16' DEEP.
- 2.) IF AN ADJACENT LANDSCAPE AREA IS A MINIMUM OF 3.5' PER ABUTTING PARKING SPACE AND PROTECTED BY CONCRETE CURBING OR WHEEL STOP, 2 FEET OF THE REQUIRED DEPTH MAY ENCROACH INTO THE LANDSCAPE AREA. IF THE REQUIRED DEPTH ENCROACHES INTO THE LANDSCAPE AREA, THE WHEEL STOP MUST BE PLACED AT THE EDGE OF PAVEMENT.
- 3.) ACCESSIBLE PARKING SPACES AND ACCESS AISLES SHALL BE CONSTRUCTED WITH SURFACE SLOPES NOT TO EXCEED 1:50 (2%) IN ALL DIRECTIONS AND THE GROUND SURFACE SHALL BE STABLE, FIRM AND SLIP RESISTANT.
- 4.) NO COLORS OTHER THAN WHITE AND BLUE SHALL BE USED FOR PARKING SPACE PAVEMENT MARKINGS.
- 5.) ALL DIMENSIONS SHOWN ARE TO THE CENTERLINE OF PAVEMENT MARKINGS.
- 6.) ALTERNATE DESIGN FOR PARKING STOPS SHALL REQUIRE APPROVAL BY THE CITY ENGINEER.

# ACCESSIBLE & TYPICAL PARKING SPACE DETAIL

N.T.S.

**CITY OF VENICE** 401 W VENICE AVE  
 VENICE, FL 34285  
 ENGINEERING DEPARTMENT (941) 486-2626

**ENGINEERING**

**ACCESSIBLE & TYPICAL PARKING**

DATE  
 JAN 2024

SHEET NO.  
**ENG-5**

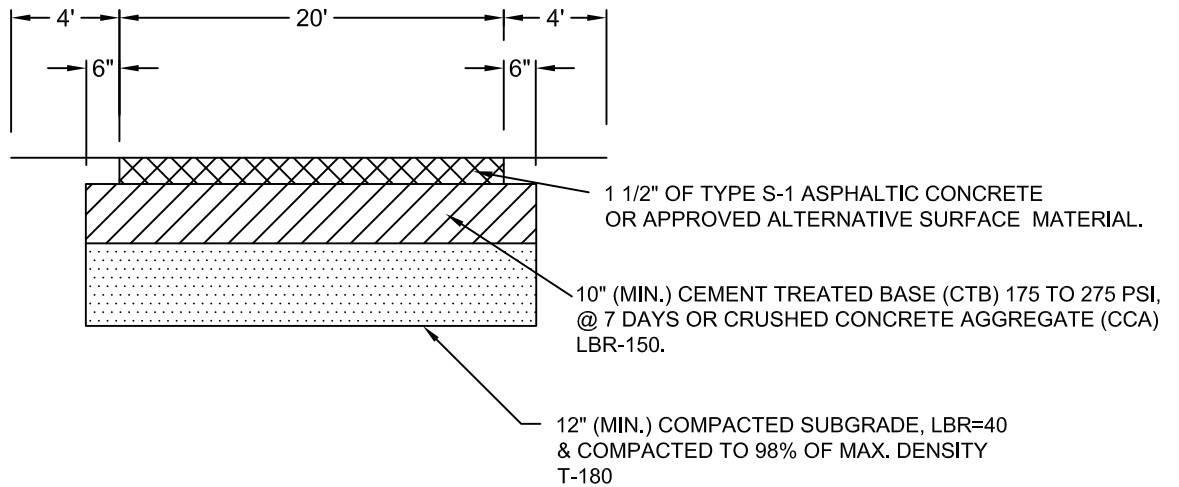

- 1.) ACCESS ROADS SHALL HAVE AN UNOBSTRUCTED WIDTH OF NOT LESS THAN 20' AND AN UNOBSTRUCTED VERTICAL CLEARANCE OF NOT LESS THAN 13'6"
- 2.) ACCESS ROADS SHALL BE DESIGNED AND MAINTAINED TO SUPPORT THE IMPOSED LOADS OF FIRE APPARATUS AND SHALL BE PROVIDED WITH A SURFACE SUITABLE FOR ALL WEATHER DRIVING CAPABILITIES.
- 3.) REQUIREMENTS MAY BE SUBJECT TO CHANGE AS PER UNIFORM FIRE CODE, FLORIDA LATEST EDITION.
- 4.) FIRE LANE SIGNS THAT COMPLY WITH THE REQUIREMENTS OF THE FLORIDA FIRE PREVENTION CODE MUST BE INSTALLED.

- EMERGENCY ACCESS SHALL BE MARKED WITH FREESTANDING SIGNS WITH THE WORDING:

**NO PARKING  
FIRE LANE  
TOW AWAY ZONE  
F.S.316-1945**

- SUCH SIGNS SHALL BE 12 INCHES BY 18 INCHES WITH A WHITE BACKGROUND AND RED LETTERS AND SHALL BE A MAXIMUM OF 7 FEET IN HEIGHT FROM THE ROADWAY TO THE BOTTOM PART OF THE SIGN.
- THE SIGNS SHALL BE WITHIN SIGHT OF THE TRAFFIC FLOW AND BE A MAXIMUM OF 60 FEET APART.

5.) IT IS IMPERATIVE THAT THIS EMERGENCY ACCESS REMAINS OPEN AT ALL TIMES. IT IS THEREFORE INCUMBENT UPON YOUR STAFF TO NOTIFY THE VENICE POLICE DEPARTMENT ANYTIME A VEHICLE IS BLOCKING THIS REQUIRED EMERGENCY ACCESS.

**EMERGENCY VEHICLE ACCESS DETAIL**

N.T.S.

**CITY OF VENICE** 401 W VENICE AVE  
VENICE, FL 34285  
ENGINEERING DEPARTMENT (941) 486-2626



**ENGINEERING**

**EMERGENCY  
VEHICLE ACCESS**

DATE  
JAN 2024

SHEET NO.  
**ENG-6**

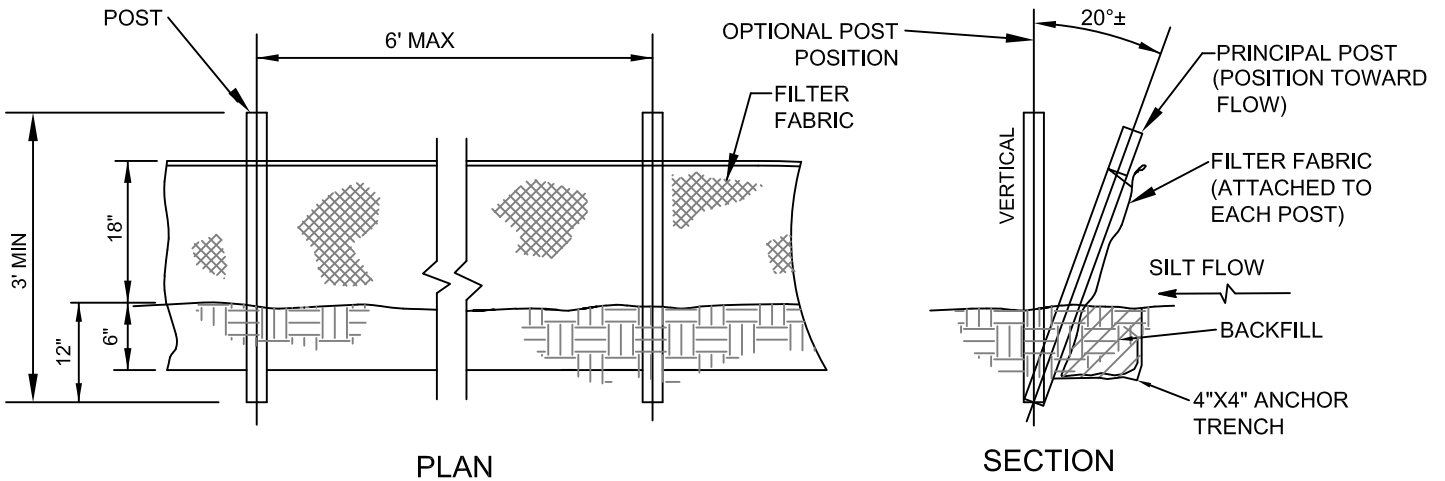

- 1.) POSTS SHALL BE WOOD (2"X4" OR 2 1/2" DIA.) OR STEEL (MIN. 1.33 LBS/FT.).
- 2.) SILT FENCE SHALL BE PLACED PRIOR TO ANY EARTHMOVING, EXCAVATION OR VEGETATION REMOVAL.
- 3.) CONTRACTOR IS RESPONSIBLE FOR MONITORING & MAINTAINING THE SILT FENCE IN GOOD CONDITION THROUGHOUT THE LIFE OF THE PROJECT.
- 4.) THE CITY ENGINEER OR HIS DESIGNEE MAY ISSUE A STOP WORK ORDER IN THE EVENT THAT SILT FENCE IS NOT BEING MAINTAINED OR IF SEDIMENT IS MIGRATING OFF-SITE.

## SILT FENCE DETAIL

N.T.S.

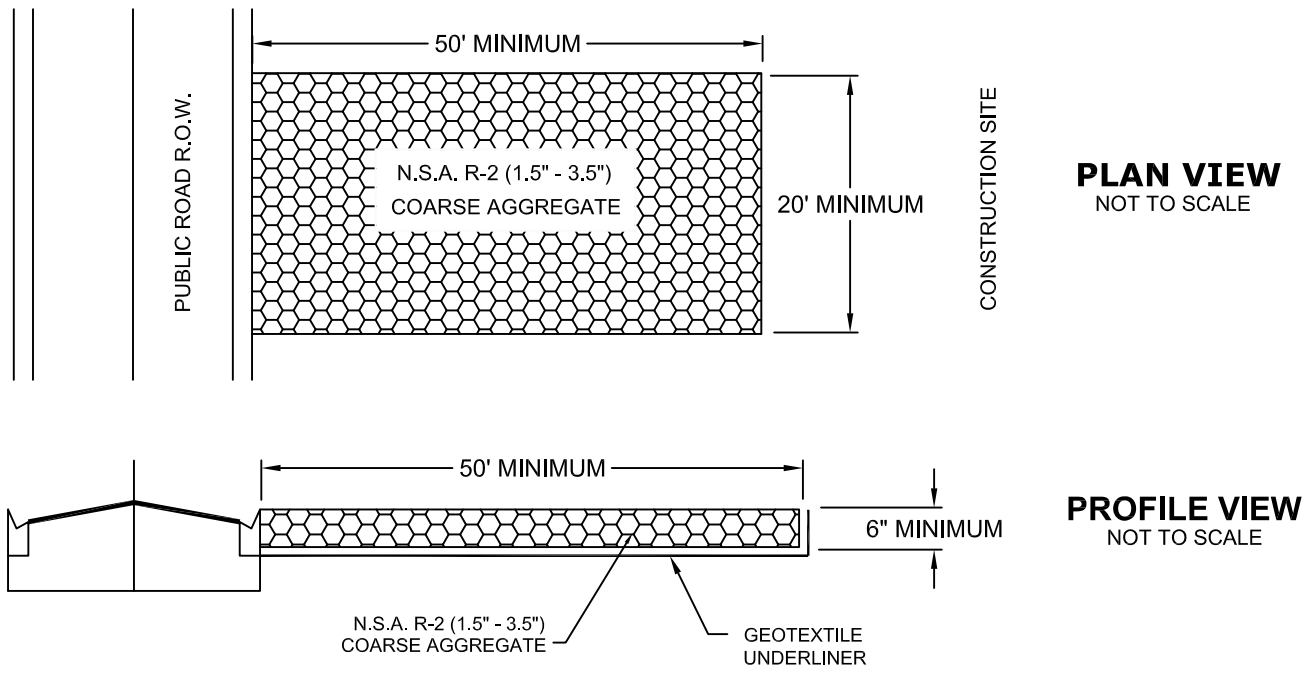

## CRUSHED STONE CONSTRUCTION EXIT DETAIL

N.T.S.

**CITY OF VENICE** 401 W VENICE AVE  
VENICE, FL 34285  
ENGINEERING DEPARTMENT (941) 486-2626



**ENGINEERING**

**SILT FENCE &  
CONSTRUCTION EXIT**

DATE  
JAN 2024

SHEET NO.  
**ENG-7**

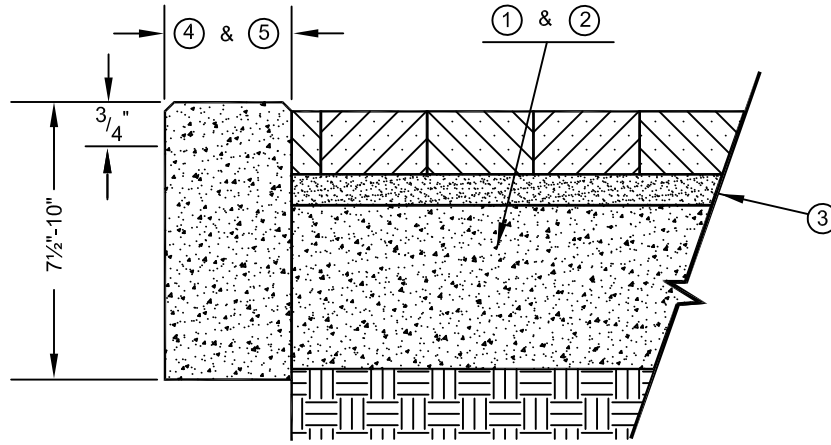

- 1.) 4" POURED CONCRETE 3,000 P.S.I. @ 28 DAYS OR COMPACTED CCA BASE FOR SIDEWALK.
- 2.) 6" POURED CONCRETE 3,000 P.S.I. @ 28 DAYS OR COMPACTED CCA BASE FOR DRIVEWAY.
- 3.) 1" MIN. TO 1½" MAX. SAND BEDDING.
- 4.) 6" POURED CONCRETE BOND BAND SHALL BE INSTALLED WHERE CURB IS NOT PRESENT WITH 3/4" REVEAL AT EDGE OF TRAVEL WAY.
- 5.) 6" POURED CONCRETE BOND BAND SHALL BE INSTALLED ON ALL OUTSIDE EDGES WHERE NO EXISTING OR NEW SOLID STRUCTURE IS PRESENT TO HOLD PAVERS IN PLACE.
- 6.) ALL PAVERS WITHIN TRAFFIC AREAS MUST BE TRAFFIC BEARING.
- 7.) A RIGHT OF WAY USE PERMIT AND AN APPROVED LICENSE AGREEMENT MUST BE OBTAINED IF PAVERS ARE TO BE INSTALLED IN CITY RIGHT OF WAY.
- 8.) WHEN CONNECTING TO AN EXISTING SIDEWALK, THE SIDEWALK THROUGH THE DRIVEWAY SHALL BE CONCRETE ACCORDING TO ENG-4. WHERE SIDEWALKS DO NOT CURRENTLY EXIST, PAVER DRIVEWAYS SHALL PROVIDE A FLAT 5 FT. WIDE SECTION, BEGINNING AT 1 FT. INSIDE THE PUBLIC ROW LINE FOR USE AS A FUTURE SIDEWALK CONNECTION. THIS SECTION SHALL BE CONCRETE ACCORDING TO ENG-4, UNLESS OTHERWISE APPROVED BY THE CITY ENGINEER.

## BRICK PAVER INSTALLATION DETAIL

N.T.S.

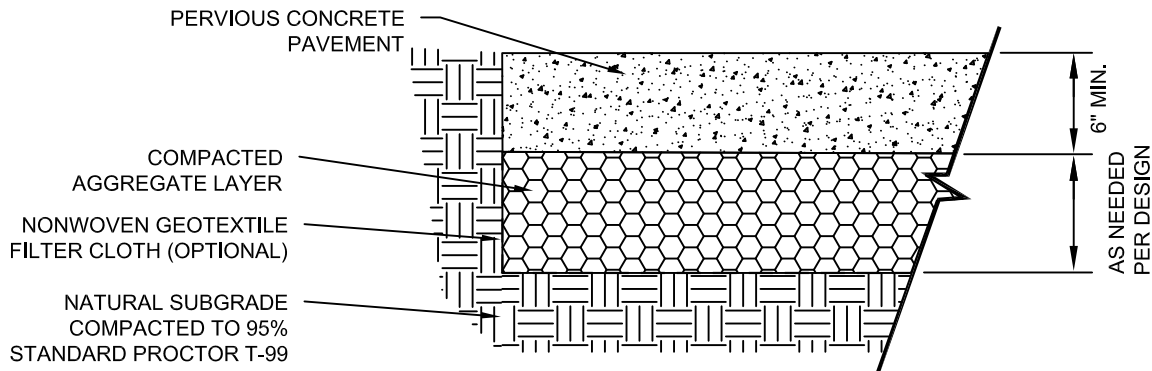

- 1.) FOR USE IN PARKING AREAS AND LOW VOLUME ACCESSWAYS ONLY.
- 2.) ENGINEER OF RECORD SHALL SUBMIT PERVIOUS PAVEMENT DESIGN AND SPECIFICATIONS BASED ON THE SITE SPECIFIC SOIL CONDITIONS, STORMWATER STORAGE REQUIREMENTS AND THE ANTICIPATED TRAFFIC LOADINGS.
- 3.) PERVIOUS CONTRACTORS SHALL BE NRMCA CERTIFIED CRAFTSMEN.
- 4.) PERVIOUS PRODUCER/SUPPLIERS AND TESTING FIRMS SHALL USE NRMCA CERTIFIED TECHNICIANS.
- 5.) POROUS ASPHALT MAY BE USED AS AN ALTERNATIVE MATERIAL AS DESIGNED BY THE EOR.

## PERVIOUS CONCRETE PAVEMENT DETAIL

N.T.S.

**CITY OF VENICE** 401 W VENICE AVE  
VENICE, FL 34285  
ENGINEERING DEPARTMENT (941) 486-2626



**ENGINEERING**

**BRICK PAVERS &  
PERVIOUS CONCRETE**

DATE  
JAN 2024

SHEET NO.  
**ENG-8**

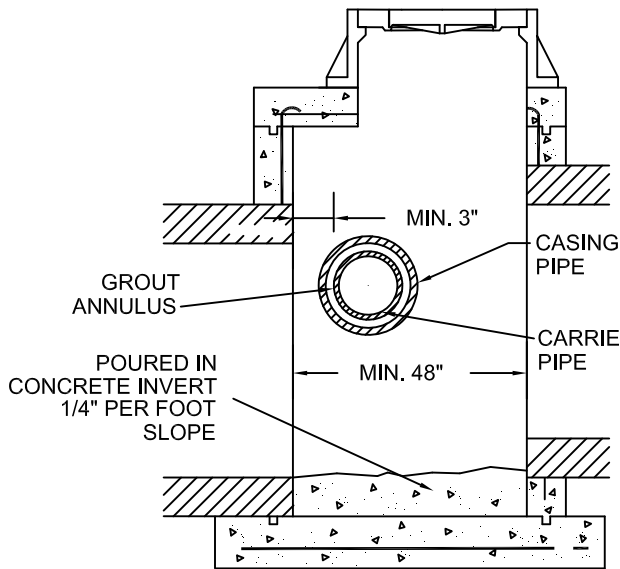

SECTION VIEW

- 1.) TYPICAL SANITARY CROSSING PIPE SHALL CLEAR WALL BY A MINIMUM OF 3".
- 2.) MANHOLE OPENING SHALL NOT BE LOCATED DIRECTLY OVER CONFLICT PIPE.
- 3.) DUCTILE IRON SLEEVE SHALL BE INSTALLED AS CASING FOR CARRIER PIPE.



PUBLIC

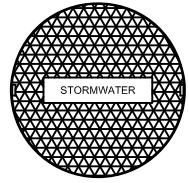

PRIVATE

(SEE S-1 FOR MANHOLE RING & COVER SPECIFICATIONS)

**STORM SEWER CONFLICT MANHOLE DETAIL**

N.T.S.

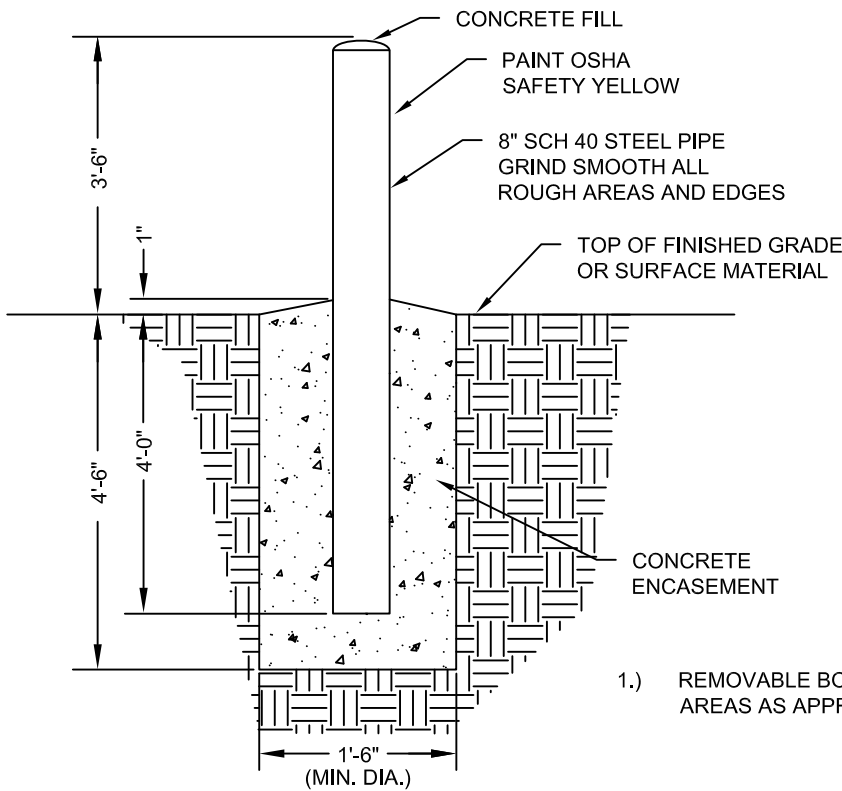

- 1.) REMOVABLE BOLLARDS SHALL BE PERMITTED IN APPROPRIATE AREAS AS APPROVED BY THE CITY ENGINEER.

**BOLLARD DETAIL**

N.T.S.

**CITY OF VENICE** 401 W VENICE AVE  
VENICE, FL 34285  
ENGINEERING DEPARTMENT (941) 486-2626



**ENGINEERING**

**STORM CONFLICT  
MANHOLE & BOLLARD**

DATE

JAN 2024

SHEET NO.

**ENG-9**

8.1 S.F.

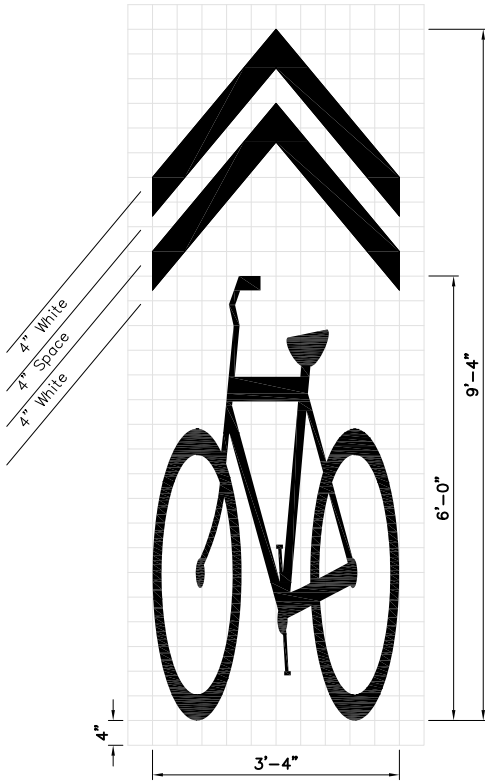

Shared Lane Marking (SLM)

6.3 S.F.

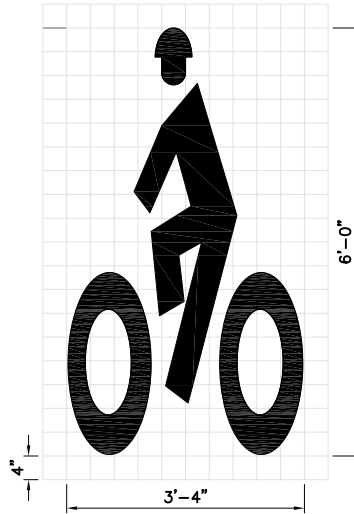

Helmeted Bicyclist Symbol

4.2 S.F.

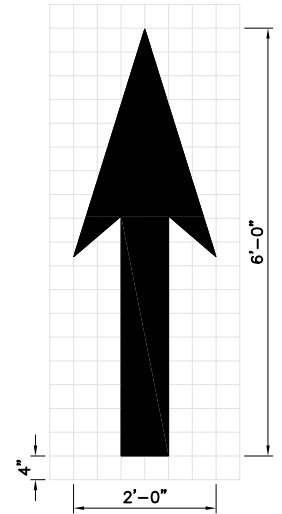

Bike Lane Arrow

- 1.) SHARED LANE MARKING SHALL BE PLACED IN THE CENTER OF THE TRAFFIC LANE.
- 2.) ALL MARKINGS SHALL BE WHITE IN COLOR AND PREFORMED THERMOPLASTIC.
- 3.) RECOMMENDED PLACEMENT OF BICYCLE LANE MARKINGS:
  - A) AT THE BEGINNING OF A BICYCLE LANE, ON THE FAR SIDE OF INTERSECTIONS AND PRIOR TO AND WITHIN THE BICYCLE LANE KEYHOLE.
  - B) ALONG THE ROADWAY WITH A MAX SPACING OF 1000 FT.
- 4.) RECOMMENDED SPACING FOR SHARED LANE MARKING: IMMEDIATELY AFTER INTERSECTIONS AND AT A MAXIMUM SPACING OF 500 FT.
- 5.) ALL MARKINGS SHALL MEET THE LATEST FDOT DESIGN STANDARDS AND SPECIFICATIONS.

## BICYCLE MARKINGS

N.T.S.

**CITY OF VENICE** 401 W VENICE AVE  
 VENICE, FL 34285  
 ENGINEERING DEPARTMENT (941) 486-2626



**ENGINEERING**

**BICYCLE  
MARKINGS**

DATE  
JAN 2024

SHEET NO.  
**ENG-10**

# **UTILITIES GENERAL DETAILS**



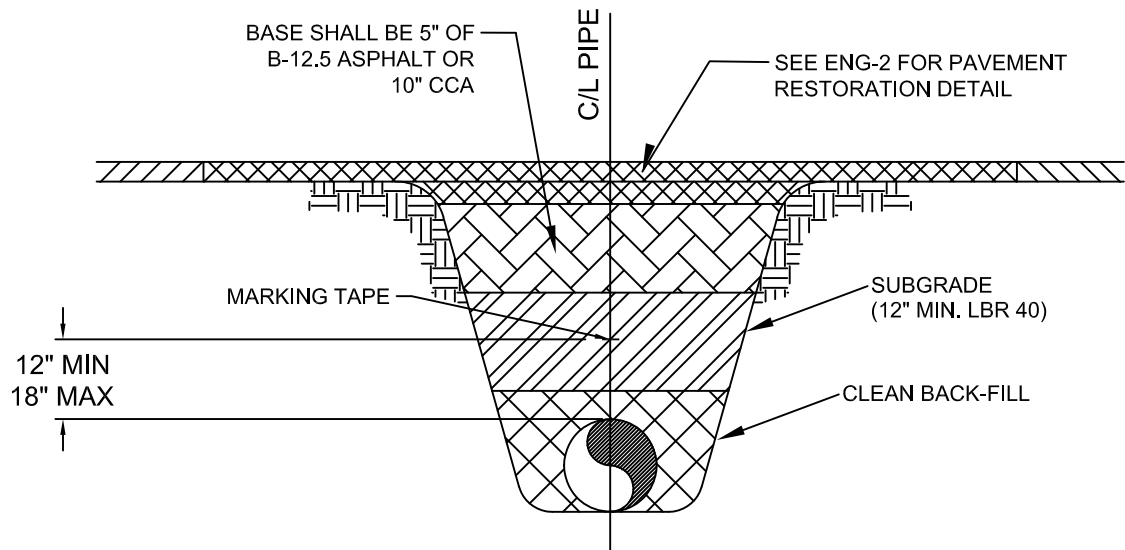

MARKING TAPE AND MESSAGES		
PIPE	TAPE COLOR	MESSAGE
PVC STORM WATER	WHITE	CAUTION STORM WATER OR STORM DRAIN BELOW
POTABLE WATER MAIN	BLUE	CAUTION POTABLE WATER MAIN BELOW
REUSE WATER MAIN	PURPLE	CAUTION REUSE WATER MAIN BELOW
SEWER FORCE MAIN	GREEN	CAUTION SEWER FORCE MAIN BELOW
SEWER & SERVICE LATERALS	GREEN	CAUTION SEWER MAIN BELOW

- 1.) COPPERHEAD TRACING WIRE #12 AWG OR EQUAL SHALL BE ATTACHED TO TOP OF PIPE AT 20' INTERVALS ON ALL RECLAIMED WATER, FORCE, OR POTABLE WATER MAINS. IT SHALL BE COLOR CODED TO REFLECT WHAT THE PIPE CARRIES. (BLUE = WATER, GREEN = SEWER, PURPLE = REUSE) WHERE TRACER WIRE NEEDS TO BE JOINED, CONNECTIONS SHALL UTILIZE DRYCON WATERPROOF CONNECTION OR APPROVED EQUAL. WIRE NUTS AND/OR DUCT TAPE ARE NOT ACCEPTABLE.
- 2.) MINIMUM COVER SHALL BE 36" FROM TOP OF PIPE TO FINISHED GRADE MAXIMUM COVER SHALL BE 42" FROM FINISHED GRADE UNLESS OTHERWISE APPROVED.
- 3.) MAINS SHALL BE INSTALLED LEVEL AND ELIMINATE HIGH POINTS UNLESS OTHERWISE APPROVED BY UTILITIES DIRECTOR.
- 4.) INSTALLATION OF PIPE SHALL BE IN CONFORMANCE WITH MANUFACTURER'S RECOMMENDATIONS.
- 5.) PAVEMENT RESTORATION SHALL CONFORM WITH DETAIL ENG-2 OF THESE CITY STANDARDS. FOR NEW CONSTRUCTION, THE FIRST LIFT OF ASPHALT SHALL BE IN PLACE PRIOR TO RECORD DRAWING REVIEW.
- 6.) CONFLICTS - UTILIZE 45° BENDS WITH SEPARATION AS PER CITY DETAILS. ALL UTILITIES (PUBLIC & PRIVATE) THAT CROSS A DITCH/SWALE SHALL BE 36" MIN.
- 7.) BELOW THE ACTUAL/DESIGN BOTTOM OF CONVEYANCE. MARKING TAPE SHALL BE 3" WIDE (MIN.) DETECTIBLE UNDERGROUND WARNING TAPE.
- 8.) INSTALL CENTERED DIRECTLY OVER THE PIPE.
- 9.) SEE S-6 FOR GRAVITY SEWER PIPE TRENCH DETAIL.

## PRESSURE PIPE TRENCH DETAIL

N.T.S.

**CITY OF VENICE** 401 W VENICE AVE  
VENICE, FL 34285  
ENGINEERING DEPARTMENT (941) 486-2626



**UTILITIES - GENERAL**

**UTILITY PIPE  
TRENCH**

DATE  
JAN 2024

SHEET NO.  
**U-1**

ABOVE GROUND ARV CONTAINMENT NOTES:

- 1) 12" HOLE MUST BE IN CENTER OF PAD.
- 2) CONTAINMENT BOX MUST BE COMPLETELY CONSTRUCTED OF STAINLESS STEEL.
- 3) CONTAINMENT BOX MUST BE EQUIPPED WITH A LOCKABLE DOOR.
- 4) THIS IS THE PREFERRED INSTALLATION IN LOW TRAFFIC AREAS.

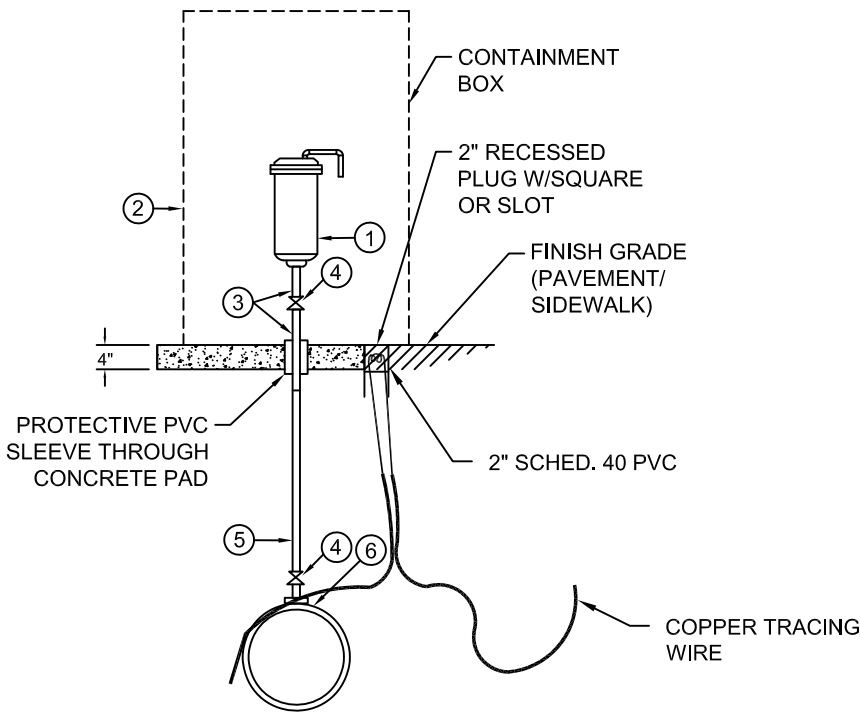
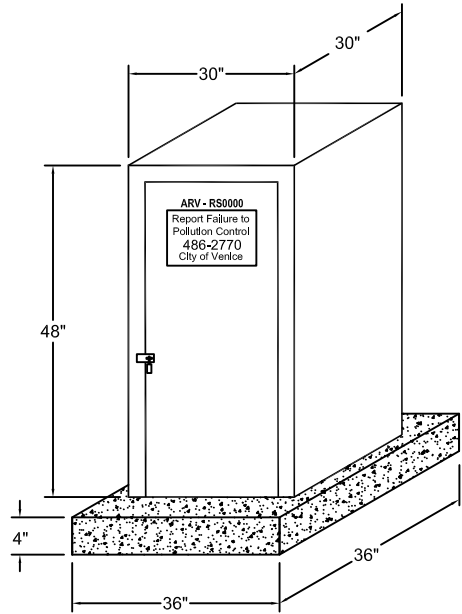

- 1) AUTOMATIC AIR RELEASE WITH BACKWASH ACCESSORIES, MANUFACTURED BY APCO MODEL 400, VAL-MATIC MODEL 48 OR H-TEC MODEL 986 FOR POTABLE & REUSE. WASTEWATER SHALL BE H-TEC MODEL 986 ONLY.
- 2) APPROVED STAINLESS STEEL ABOVE GROUND VALVE BOX SECTION WITH TOP SLAB, ASTM C478, LATEST REVISION.
- 3) PIPE AND FITTINGS SHALL BE THREADED SCH 80 STAINLESS STEEL 316
- 4) SS 316 BALL VALVE
- 5) POLYTUBING
- 6) SERVICE SADDLE (INCLUDING BODY) SHALL BE STAINLESS STEEL TPS SERIES T3 WITH SS 316 BAND(S) AND HARDWARE
- 7) CAV's SHALL BE PLACED AT THE HIGH POINT OF THE MAIN.
- 8) PIPE CAV's DISCHARGE TO NEAREST GRAVITY SEWER MANHOLE (SEWER & REUSE ONLY).

## AUTOMATIC COMBINATION AIR RELEASE VALVE (CAV) DETAIL

N.T.S.

**CITY OF VENICE** 401 W VENICE AVE  
VENICE, FL 34285  
ENGINEERING DEPARTMENT (941) 486-2626



**UTILITIES - GENERAL**

**AUTO. COMBINATION  
AIR RELEASE VALVE**

DATE  
JAN 2024

SHEET NO.  
**U-2**

# ALTERNATE

REQUIRES APPROVAL OF UTILITIES DEPARTMENT

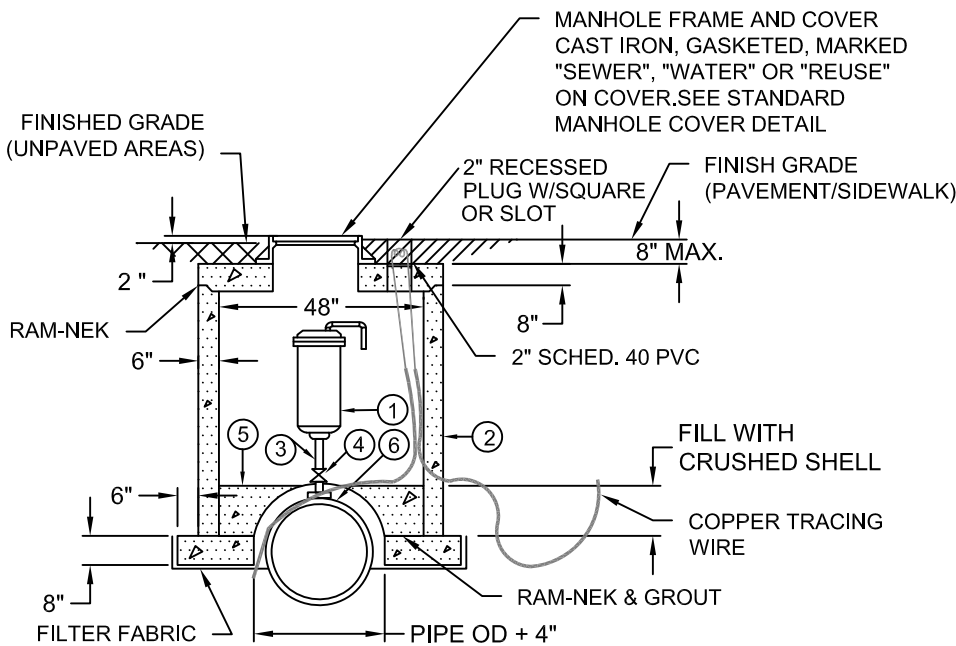
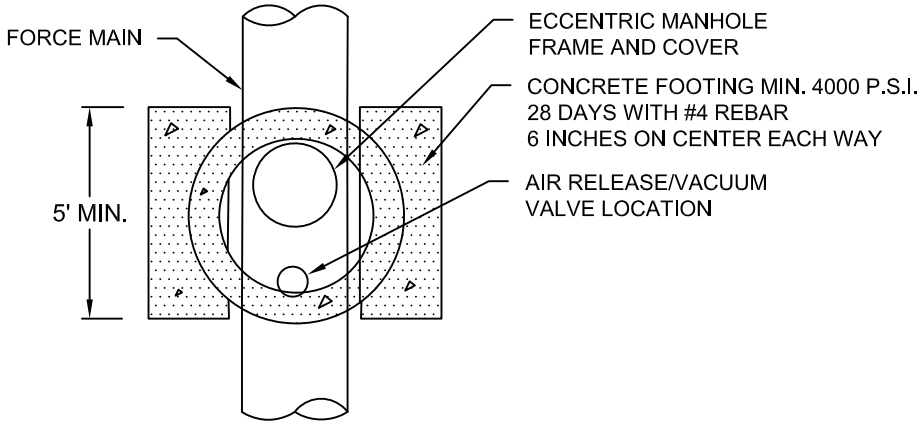

- 1) AUTOMATIC AIR RELEASE WITH BACKWASH ACCESSORIES, H-TEC MODEL 986 FOR POTABLE & REUSE. WASTEWATER SHALL BE H-TEC MODEL 986 ONLY.
- 2) PRECAST CONCRETE 4 FOOT DIA. MANHOLE.
- 3) PIPE AND FITTINGS SHALL BE THREADED SCH 80 SS 316
- 4) SS 316 BALL VALVE
- 5) CRUSHED SHELL
- 6) ALL SS DOUBLE BAND SERVICE SADDLE (INCLUDING BODY).
- 7) CAV's SHALL BE PLACED AT THE HIGH POINT OF THE MAIN.
- 8) PIPE CAV's DISCHARGE TO NEAREST GRAVITY SEWER MANHOLE (SEWER & REUSE ONLY).

## AUTOMATIC COMBINATION AIR RELEASE VALVE (CAV) DETAIL (ALTERNATE)

N.T.S.

**CITY OF VENICE** 401 W VENICE AVE  
VENICE, FL 34285  
ENGINEERING DEPARTMENT (941) 486-2626



**UTILITIES - GENERAL**

**AUTO. COMBINATION  
AIR RELEASE VALVE**

DATE  
JAN 2024

SHEET NO.  
**U-2a**

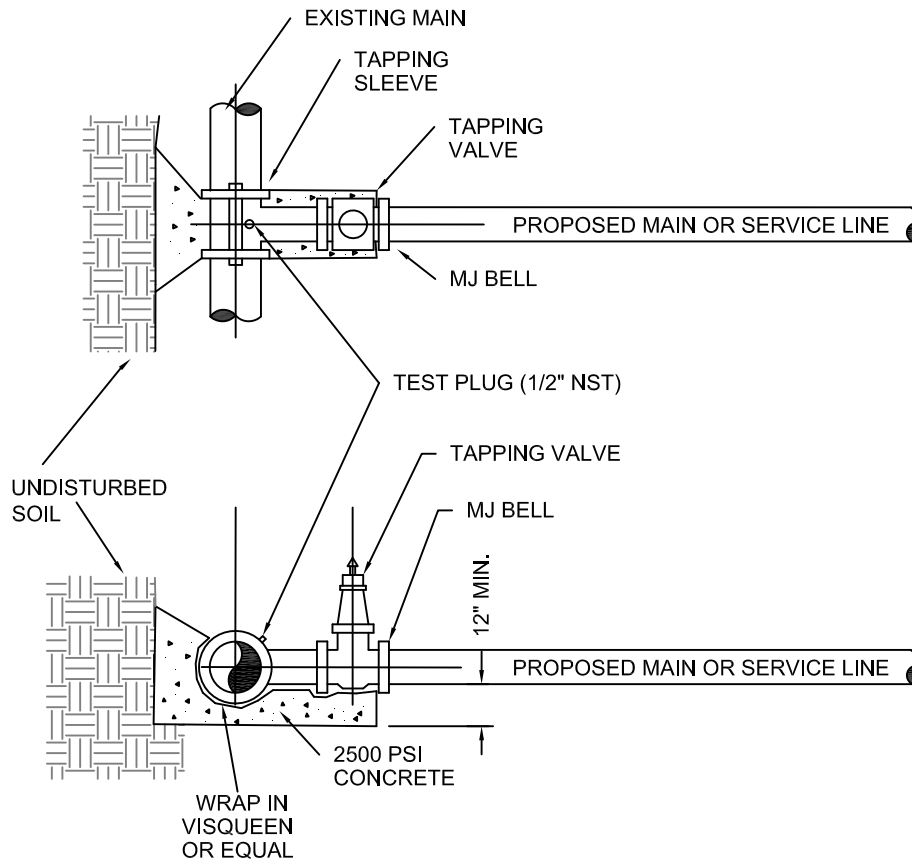

- 1.) EXISTING MAIN SHALL NOT BE TAPPED UNTIL THE ASSEMBLED SLEEVE AND VALVE ARE TESTED IN PLACE AT A MINIMUM OF 150 PSI FOR THIRTY MINUTES.
- 2.) UPON SUCCESSFUL TAPPING SLEEVE PRESSURE TEST (NOTE 1), THE THRUST BLOCK SHALL BE POURED AND HAVE SET FOR 24 HRS PRIOR TO TAPPING. READY-MADE THRUST BLOCKS CAN BE USED WITH CITY APPROVAL.
- 3.) STAINLESS STEEL TAPPING SLEEVE SHALL BE FORD. ALL HARDWARE SHALL BE 316 STAINLESS STEEL. GASKETS SHALL BE VIRGIN SBR COMPOUND.
- 4.) GATE VALVES SHALL BE RESILIENT WEDGE-TYPE MANUFACTURED BY MUELLER OR AMERICAN VALVE. ALL GATE VALVES SHALL BE FUSION BONDED EPOXY COATED (INTERIOR AND EXTERIOR) MEET ANSI/AWWA C550, AND BE NSF61 CERTIFIED.
- 5.) TAPPING SLEEVES MAY ONLY BE USED WHEN THE TAP DIAMETER IS AT LEAST ONE PIPE SIZE SMALLER THAN THE DIAMETER OF THE MAIN BEING TAPPED. TRANSMISSION MAINS SHALL NOT BE TAPPED WITH A TAP LESS THAN 4" IN DIAMETER.
- 6.) TAPPING/SERVICE SADDLES MAY BE USED FOR TAPS UP TO AND INCLUDING 2" DIAMETER.
- 7.) ALL TAPS SHALL BE WHOLE NUMBER NOMINAL SIZES, INCLUDING 1", 2", 4", ETC.
- 8.) VALVE BOX ALIGNMENT DEVICE SHALL BE INSTALLED IN ACCORDANCE WITH W-1 ON ALL VALVES ABOVE 1".

## TAPPING SLEEVE & VALVE DETAIL

N.T.S.

**CITY OF VENICE** 401 W VENICE AVE  
VENICE, FL 34285  
ENGINEERING DEPARTMENT (941) 486-2626



**UTILITIES - GENERAL**

**TAPPING SLEEVE  
& VALVE**

DATE  
JAN 2024

SHEET NO.  
**U-3**

VALVE SIZE (I.E. 8)  
 TYPE (GV)  
 SERVICE (REUSE)  
 DIRECTION & # OF TURNS TO OPEN (I.E. L-10)  
 YEAR INSTALLED (I.E. 2017)

3" DIA. BRASS DISK  
 W/STEM EMBEDDED  
 INTO CONCRETE &  
 DISK FLUSH W/PAD

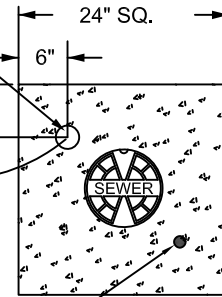

**PLAN**

COPPERHEAD SNAKEPIT 2-TERMINAL  
 SWITCHABLE LID WITH COLOR INDICATED  
 FOR 12 AWG COPPER TRACING WIRE  
 PLACED FLUSH WITH PAD. NO PVC LIDS.  
 TRACER WIRE MUST BE TESTABLE  
 WITHOUT REMOVING THE LID.

24"X24"X6" CONCRETE PAD  
 (3000 PSI AT 28 DAYS WITH  
 FIBER REINFORCEMENT)

VALVE BOX SHALL BE DUCTILE IRON  
 OR PVC WITH IRON RING AND COVER.  
 ANY APPURTENANCES IN THE ROAD  
 SHALL BE H-20 TRAFFIC RATED.

COMPACT BACKFILL  
 AROUND TOP SECTION  
 AND VALVE

12 AWG COPPER  
 TRACING WIRE

2" SCHED. 40 PVC

**PROFILE**

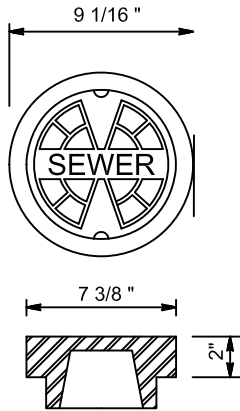

**COVER DETAIL**

APPROPRIATE SERVICE TYPE  
 SHALL BE INDICATED  
 (WATER, SEWER, REUSE, OR FIRE)

- 1.) PAVED AREAS: SET CONCRETE PAD AND COVER FLUSH WITH FINISHED PAVEMENT SURFACE.
- 2.) UNPAVED AREAS: SET PAD AND COVER 1 INCH ABOVE FINISHED GRADE.
- 3.) VALVES LOCATED IN DITCH AND OVER 4' DEPTH (LINE) MUST USE TRENCH ADAPTER VALVE BOX (AMERICAN FLOW CONTROL).
- 4.) COPPERHEAD TRACING WIRE #12 AWG OR EQUAL SHALL BE USED. IT SHALL BE COLOR CODED TO REFLECT WHAT THE PIPE CARRIES (BLUE = WATER, GREEN = SEWER, PURPLE = REUSE). CONTRACTOR SHALL PERFORM CONTINUITY TEST ON ALL TRACER WIRES, WITNESSED BY CITY REPRESENTATIVE. WHERE TRACER WIRE NEEDS TO BE JOINED, CONNECTIONS SHALL UTILIZE DRYCON WATERPROOF CONNECTION OR APPROVED EQUAL. WIRE NUTS AND/OR DUCT TAPE ARE NOT ACCEPTABLE.
- 5.) PRE-CAST PADS MAY BE USED WITH CITY APPROVAL.
- 6.) FOR CURBED ROADWAYS: CURB SHALL BE ETCHED WITH THE LETTER "V" DIRECTLY PERPENDICULAR TO THE VALVE BOX.
- 7.) VALVE BOX COVERS SHALL BE PAINTED BLUE FOR POTABLE WATER, PURPLE FOR REUSE WATER, AND GREEN FOR SEWER.

**VALVE BOX DETAIL**

N.T.S.

**CITY OF VENICE** 401 W VENICE AVE  
 VENICE, FL 34285  
 ENGINEERING DEPARTMENT (941) 486-2626



**UTILITIES - GENERAL**

**VALVE BOX**

DATE  
 JAN 2024

SHEET NO.  
 U-4

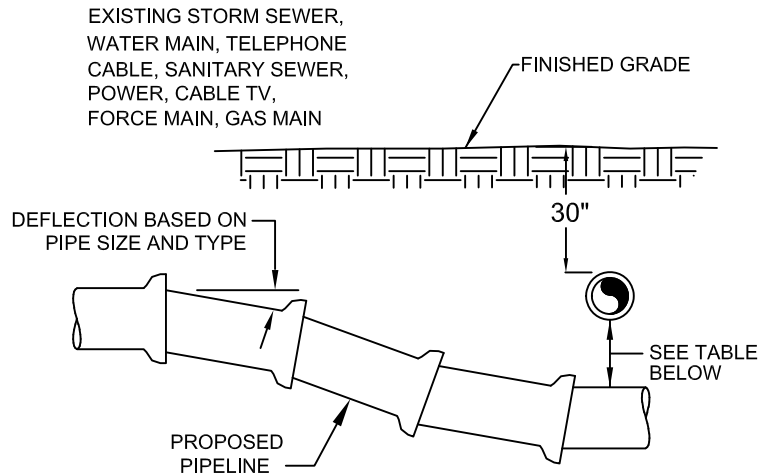
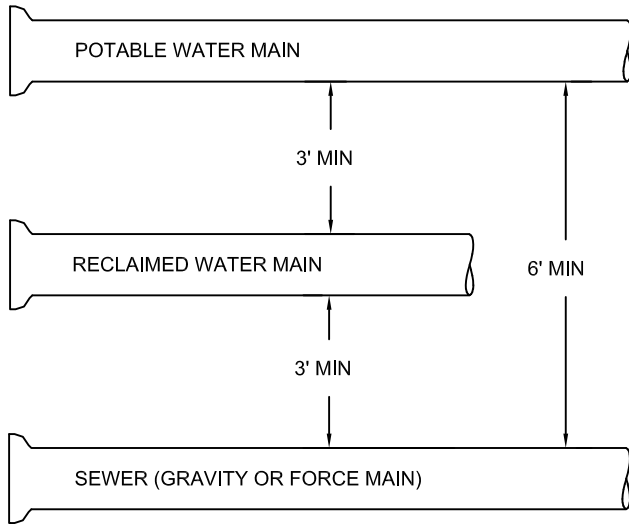

## MINIMUM HORIZONTAL SEPARATION DISTANCES (FT)

(OUTSIDE OF PIPELINE TO OUTSIDE OF PIPELINE)

	WATER MAIN	FORCE MAIN	SANITARY SERVICE	REUSE MAIN	STORM WATER	OTHER UTILITIES (TELEPHONE, CABLE, ETC.)
WATER MAIN	3	6	6	3	3	3
FORCE MAIN	6	3	3	3	3	3
SANITARY SEWER	6	3	3	3	3	3
REUSE MAIN	3	3	3	3	3	3
STORM WATER	3	3	3	3	3	3
OTHER UTILITIES	3	3	3	3	3	3

## MINIMUM VERTICAL SEPARATION DISTANCES (IN)

(OUTSIDE OF PIPELINE TO OUTSIDE OF PIPELINE)

	WATER MAIN	FORCE MAIN	SANITARY SERVICE	REUSE MAIN	STORM WATER	OTHER UTILITIES (TELEPHONE, CABLE, ETC.)
WATER MAIN	6	12	12	6	6	6
FORCE MAIN	12	6	6	6	6	6
SANITARY SEWER	12	6	6	6	6	6
REUSE MAIN	6	6	6	6	6	6
STORM WATER	6	6	6	6	6	6
OTHER UTILITIES	6	6	6	6	6	6

- 1.) MAXIMUM JOINT DEFLECTION SHALL BE 90% OF MANUFACTURER'S RECOMMENDATION.
- 2.) WHEREVER POSSIBLE, THE LAYOUT OF UTILITIES SHALL PLACE SANITARY SEWER AND SEWER FORCE MAINS BELOW RECLAIMED MAINS AND BELOW WATER MAINS, RESPECTIVELY. WHERE WATER MAINS ARE ABOVE GRAVITY SEWERS OR WASTEWATER FORCE MAINS, A VERTICAL CLEARANCE OF 6 INCHES IS ACCEPTABLE. STORM SHALL BE PLACED BELOW BOTH WATER AND SEWER WHERE POSSIBLE.
- 3.) ACCEPTABLE VARIANCES:
  - A. WHERE HORIZONTAL SEPARATION CANNOT BE MAINTAINED, C900 DR14 PVC PIPE SHALL BE USED FOR ONE OF THE PIPELINES.
  - B. WHERE VERTICAL CLEARANCE CANNOT BE MAINTAINED, ONE FULL LENGTH OF DR14 C900 PIPE SHALL BE INSTALLED CENTERED AT THE POINT OF CROSSING.
  - C. WHERE 36" MINIMUM DEPTH OF COVER CANNOT BE MAINTAINED, SPECIAL PROTECTION OR PIPE MATERIAL UPGRADE MAY BE REQUIRED, AT THE DISCRETION OF THE UTILITY DEPARTMENT.
- 4.) NO UTILITY PIPE SHALL PASS THROUGH, OR COME IN CONTACT WITH ANY PART OF A SANITARY MANHOLE OR STORMWATER STRUCTURE WITHOUT APPROVAL FROM THE UTILITIES DIRECTOR OR CITY ENGINEER.

## UTILITY CONFLICT & SEPARATION DETAIL

N.T.S.

**CITY OF VENICE** 401 W VENICE AVE  
VENICE, FL 34285  
ENGINEERING DEPARTMENT (941) 486-2626



**UTILITIES - GENERAL**

**UTILITY CONFLICTS & SEPARATIONS**

DATE  
JAN 2024

SHEET NO.  
**U-5**

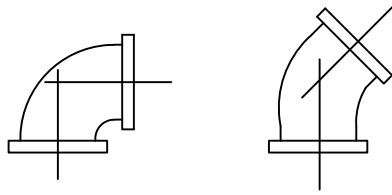

- 1.) ALL PIPE FITTINGS SHALL BE COMPACT, DUCTILE IRON.
- 2.) ALL APPLICATIONS (RAW, POTABLE, REUSE, SEWER) SHALL BE FUSION BONDED EPOXY COATED INSIDE AND OUT.
- 3.) ALL FITTINGS SHALL MEET ANSI/AWWA C116/A21.16 STANDARDS.
- 4.) ALL HARDWARE SHALL BE 316 SS.
- 5.) ALL FITTINGS FOR SANITARY SEWER SHALL BE HEAVY WALL SDR 26 PVC.

## PIPE FITTINGS

N.T.S.

SERVICE	COLOR	MATERIAL/CLASS
POTABLE WATER MAIN	BLUE	AWWA C900 PVC / DR 18 FUSIBLE C900 PVC / DR 18 CERT-A-LOK C900 PVC / DR 18 HDPE PPI PE 4710 / DR 11 / DIPS (WITH UTILITIES DEPARTMENT APPROVAL)
RAW WATER MAIN	WHITE	
REUSE MAIN	PURPLE	
FORCE MAIN (MIN. 4" DIAMETER)	GREEN	
WATER SERVICE	BLUE	PE (POLYTUBING) / DR 9
REUSE SERVICE	PURPLE	PE (POLYTUBING) / DR 9
GRAVITY SEWER MAIN (MIN. 8" DIAMETER)	GREEN	ASTMD3034 / SDR 26
SEWER LATERAL (MIN. 6" DIAMETER)	GREEN	ASTMD3034 / SDR 26

## PIPE MATERIAL SCHEDULE

N.T.S.

**CITY OF VENICE** 401 W VENICE AVE  
 ENGINEERING DEPARTMENT VENICE, FL 34285  
 (941) 486-2626



**UTILITIES - GENERAL**

**PIPE FITTINGS &  
MATERIAL**

DATE  
JAN 2024

SHEET NO.  
**U-6**

MINIMUM LENGTH (FT) OF FORCE MAIN TO BE RESTRAINED ON EACH SIDE OF FITTING										
FITTING	PIPE SIZE (INCHES)									
	4	6	8	10	12	16	18	20	24	
45 BEND:	H	6	9	12	14	16	21	23	25	29
	VU	4	6	7	9	10	13	15	16	19
	VD	12	20	26	32	37	48	53	28	68
22.5 BEND:	H	3	4	6	7	8	10	11	12	14
	VU	2	3	4	4	5	6	7	8	9
	VD	7	10	13	15	18	23	26	28	33
11.25 BEND:	H	2	2	3	3	4	5	5	6	7

MINIMUM LENGTH (FT) OF WATER OR REUSE MAIN TO BE RESTRAINED ON EACH SIDE OF FITTING										
FITTING	PIPE SIZE (INCHES)									
	4	6	8	10	12	16	18	20	24	
90 BEND:	H	23	33	43	51	60	76	83	90	104
45 BEND:	H	10	14	18	21	25	31	34	37	43
	VU	6	8	11	13	16	20	22	24	28
	VD	22	30	40	48	56	72	80	87	102
22.5 BEND:	H	5	7	8	10	12	15	17	18	21
	VU	3	4	5	6	7	10	11	12	14
	VD	10	15	19	23	27	35	38	42	49
11.25 BEND:	H	2	3	4	5	6	7	8	9	10
VALVES/PLUGS:		52	73	96	115	136	174	193	211	246

ABBREVIATIONS: H=HORIZONTAL, VU=VERTICAL UP, VD=VERTICAL DOWN.

- FOR TEE OR REDUCER FITTINGS SUBMIT RESTRAINED JOINT LENGTH CALCULATIONS TO CITY ENGINEER FOR REVIEW AND APPROVAL, USING THE ASSUMPTIONS LISTED ABOVE.
- RESTRAINED JOINT LENGTH FOR WATER AND REUSE MAINS BASED ON TEST PRESSURE OF 150 PSI. RESTRAINED JOINT LENGTH FOR FORCE (SEWER) MAINS BASED ON TEST PRESSURE OF 100 PSI. CALCULATIONS WERE MADE USING EBAA IRON SOFTWARE (AVAILABLE AT WWW.EBAA.COM) AND THE FOLLOWING ASSUMPTIONS: GRANULAR MATERIAL (GM) SOIL TYPE, TRENCH TYPE 3, BURY DEPTH OF 3 FT, AND SAFETY FACTOR OF 2 TO 1. IF FIELD CONDITIONS DIFFER FROM ABOVE ASSUMPTIONS EOR SHALL PROVIDE CALCULATIONS BASED ON ACTUAL CONDITIONS.
- RESTRAINED JOINT SHALL BE USED ON ALL JOINTS FROM ANY MAIN TEE TO ANY FIRE HYDRANT ASSEMBLY.
- THRUST BLOCKS WILL NOT BE ACCEPTED, UNLESS OTHERWISE APPROVED BY THE CITY ENGINEER.
- ALL HARDWARE SHALL BE 316 SS.

## PRESSURE MAIN RESTRAINED JOINT TABLE

N.T.S.

**CITY OF VENICE** 401 W VENICE AVE  
VENICE, FL 34285  
ENGINEERING DEPARTMENT (941) 486-2626



**UTILITIES - GENERAL**

**RESTRAINED  
JOINT TABLE**

DATE  
JAN 2024

SHEET NO.  
**U-7**



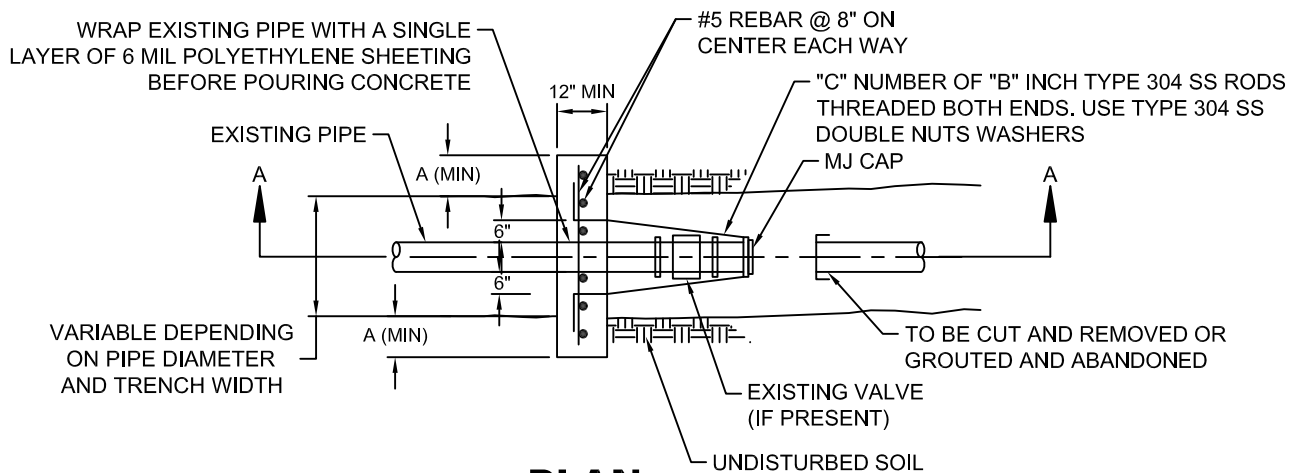

**PLAN**

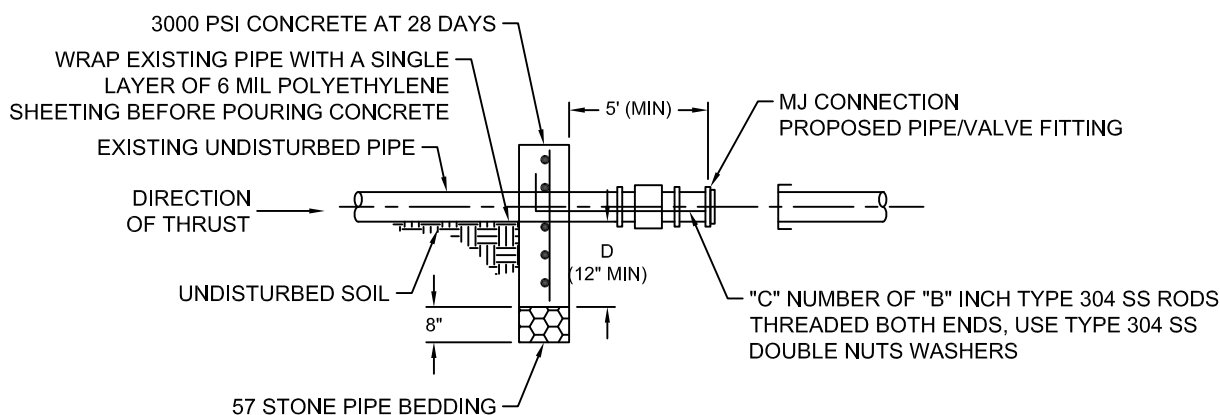

**SECTION A-A**

1. ADDITIONAL REINFORCEMENT SHALL BE AS SPECIFIED BY THE ENGINEER OF RECORD.
2. MINIMUM COMPRESSIVE STRENGTH OF CONCRETE SHALL BE 3000 PSI.
3. PIPE TRENCH SHALL BE PER U-1.
4. ALL FORM BOARDS SHALL BE REMOVED PRIOR TO BACKFILL.
5. NO ALLOWANCE SHALL BE MADE FOR FRICTION BETWEEN THE PIPE WALL AND THE THRUST COLLAR.
6. CHART FIGURES CALCULATED FOR THE 1000 PSF SOIL BEARING 150 PSI LINE PRESSURE AND A 1:5 FACTOR OF SAFETY.
7. RESTRAIN VALVE TO CONCRETE COLLAR BEFORE CUTTING PIPE TO BE REMOVED OR ABANDONED. REMOVE VALVE BOX.
8. USE COUPLINGS AS NECESSARY TO CONNECT RODS FROM VALVE TO CAP.
9. FILL DISTURBED AREA UNDER PIPE TO REMAIN IN SERVICE WITH EXCAVATABLE FLOWABLE FILL.

PIPE SIZE D (INCHES)	DIMENSIONS (INCHES)		TIE RODS REQ'D
	A	B	C
4	15	1/2	2
6	22	1/2	2
8	30	5/8	2
10	39	5/8	3
12	49	5/8	5
16	70	3/4	5

## WATER MAIN ABANDONMENT END RESTRAINT

N.T.S.

**CITY OF VENICE** 401 W VENICE AVE  
VENICE, FL 34285  
ENGINEERING DEPARTMENT (941) 486-2626



**UTILITIES - GENERAL**  
**WATER MAIN**  
**ABANDONMENT END**  
**RESTRAINT**

DATE  
JAN 2024

SHEET NO.  
**U-8**

# **UTILITIES**

## **WATER DETAILS**

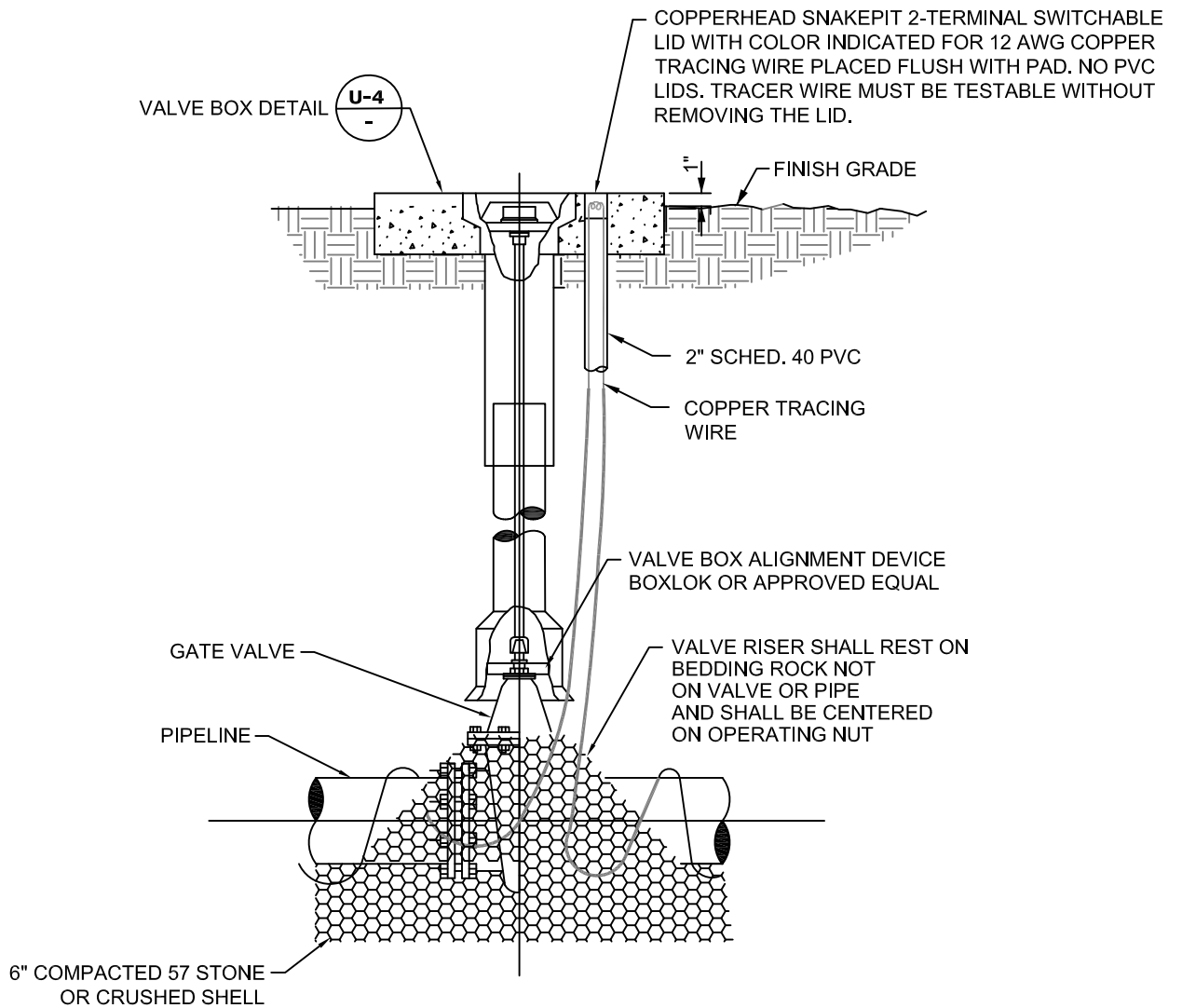

- 1.) GATE VALVES SHALL BE RESILIENT WEDGE-TYPE MANUFACTURED BY MUELLER, AMERICAN VALVE, OR EQUAL. ALL GATE VALVES SHALL BE FUSION BONDED EPOXY COATED (INTERIOR AND EXTERIOR) MEET ANSI/AWWA C550, AND BE NSF61 CERTIFIED. BRANCH VALVES SHALL BE LOCATED AS CLOSE AS POSSIBLE TO THE TEE.
- 2.) GATE VALVES SHALL BE NOMINAL SIZES: 2", 4, 6", ETC. NO GATE VALVES SMALLER THAN 2". FOR VALVES LARGER THAN 12" IN USE BUTTERFLY STYLE VALVE.
- 3.) VALVE SHALL BE INSTALLED IN CONFORMANCE WITH MANUFACTURER'S RECOMMENDATIONS.
- 4.) COPPERHEAD TRACING WIRE PART #12 AWG OR EQUAL SHALL BE USED. IT SHALL BE COLOR CODED TO REFLECT WHAT THE PIPE CARRIES. (BLUE = WATER, PURPLE = REUSE)
- 5.) FOR CURBED ROADWAYS: CURB SHALL BE ETCHED WITH THE LETTER "V" DIRECTLY PERPENDICULAR TO THE VALVE BOX.
- 6.) ALL BOLTS AND HARDWARE SHALL BE 316 SS.
- 7.) SIGNIFICANT UTILITY CROSSINGS, SUCH AS DITCHES, WATER BODIES, AND MAJOR ROADS, SHALL HAVE ISOLATION VALVES ON EACH SIDE OF THE CROSSING.

## GATE VALVE DETAIL

(WATER AND REUSE ONLY)  
N.T.S.

**CITY OF VENICE** 401 W VENICE AVE  
VENICE, FL 34285  
ENGINEERING DEPARTMENT (941) 486-2626



**UTILITIES - WATER**

# GATE VALVE

DATE  
JAN 2024

SHEET NO.  
**W-1**

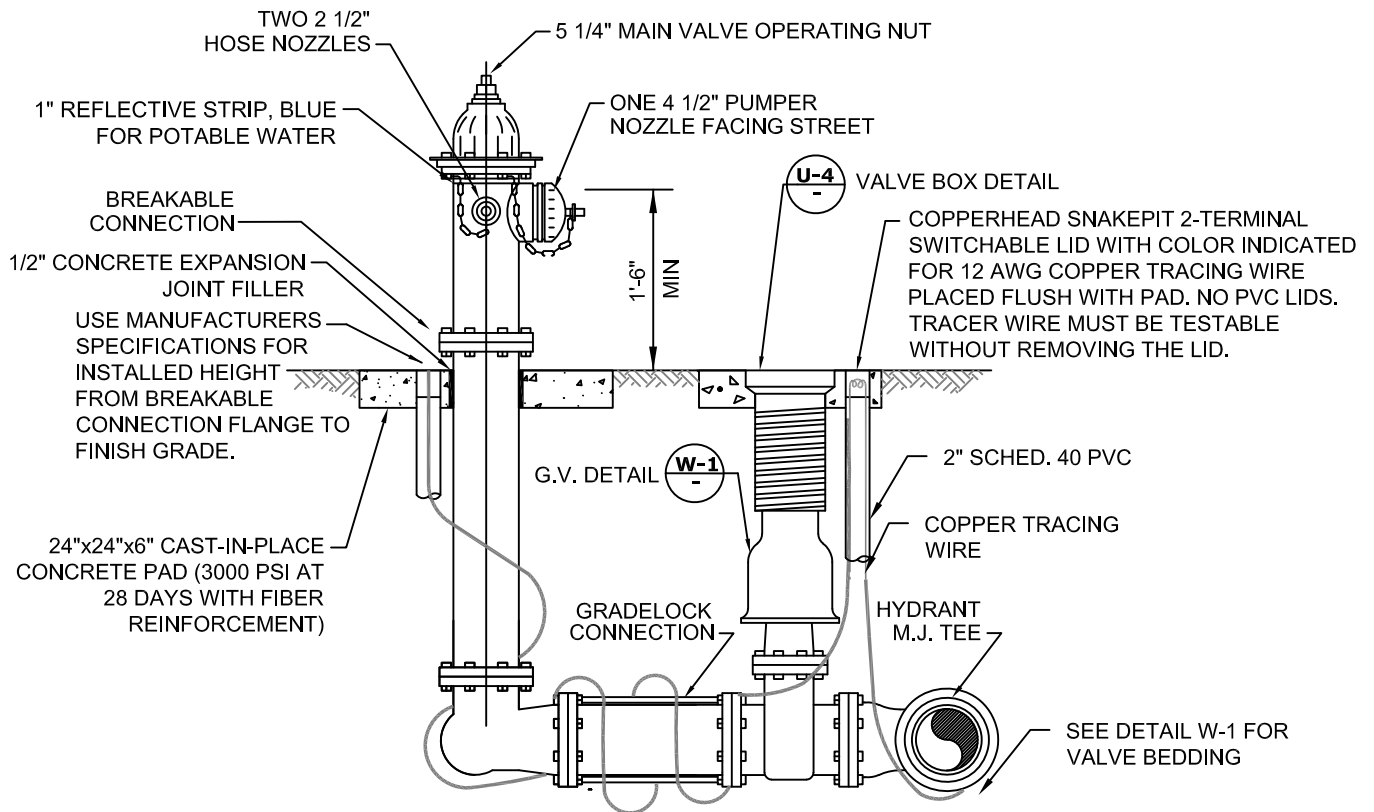

**NOTES:**

- 1.) POTABLE WATER FIRE HYDRANTS SHALL BE PAINTED "SAFETY YELLOW".
- 2.) REUSE FIRE HYDRANTS SHALL BE PAINTED PANTONE PURPLE 522C AND TAGGED WITH A PERMANENT LABEL "RECLAIMED WATER-DO NOT DRINK."
- 3.) HYDRANT SHALL BE MUELLER SUPER CENTURIAN MODEL A423, AMERICAN B84B-5 WITH BREAK-AWAY FEATURE. ALL BOLTS SHALL BE SS (BONNET, SAFETY FLANGE, SHOE).
- 4.) RESTRAINED JOINTS SHALL BE USED BETWEEN TEE AND HYDRANT.
- 5.) HYDRANTS SHALL HAVE "OUT OF SERVICE" TAGS AND BE BAGGED UNTIL MAINS ARE ACCEPTED BY CITY.
- 6.) ALL WEEP HOLES SHALL BE PLUGGED.
- 7.) HYDRANT LOCATED AT LEAST 3' OR MORE FROM ANY STORM WATER PIPE OR DITCH AND AT LEAST 6' OR MORE FROM ANY SANITARY SEWER STRUCTURE. FOR CLEARANCE ISSUES, PLEASE REFER TO CURRENT FLORIDA FIRE PREVENTION CODE REQUIREMENTS.
- 8.) RAISED REFLECTIVE PAVEMENT MARKERS (RPM), BLUE FOR POTABLE WATER, SHALL BE INSTALLED ON THE PAVEMENT DIRECTLY ACROSS FROM THE HYDRANT IN ACCORDANCE WITH THE FDOT TRAFFIC ENGINEERING MANUAL, CHAPTER 4, SECTION 4.3 OR MOST CURRENT ADDITION.
- 9.) COPPERHEAD TRACING WIRE #12 AWG OR EQUAL SHALL BE USED. IT SHALL BE COLOR CODED TO REFLECT WHAT THE PIPE CARRIES. (BLUE = WATER, PURPLE = REUSE)
- 10.) ASSEMBLY SHALL BE BEDDED IN 8" OF 57 STONE OR CRUSHED SHELL AND INSTALLED AT PROPER BURIAL DEPTH.
- 11.) FIRE HYDRANT ASSEMBLY INCLUDES GATE VALVE TO BE LOCATED AS CLOSE TO WATER MAIN AS POSSIBLE.
- 12.) GRADE-LOK CONNECTION MAY BE USED BETWEEN VALVE AND HYDRANT. FUSION BONDED EPOXY. ROTATE TO FINAL GRADE.

## FIRE HYDRANT ASSEMBLY DETAIL

N.T.S.

**CITY OF VENICE** 401 W VENICE AVE  
 VENICE, FL 34285  
 ENGINEERING DEPARTMENT (941) 486-2626



**UTILITIES - WATER**

**FIRE HYDRANT  
 ASSEMBLY**

DATE  
 JAN 2024

SHEET NO.  
**W-2**

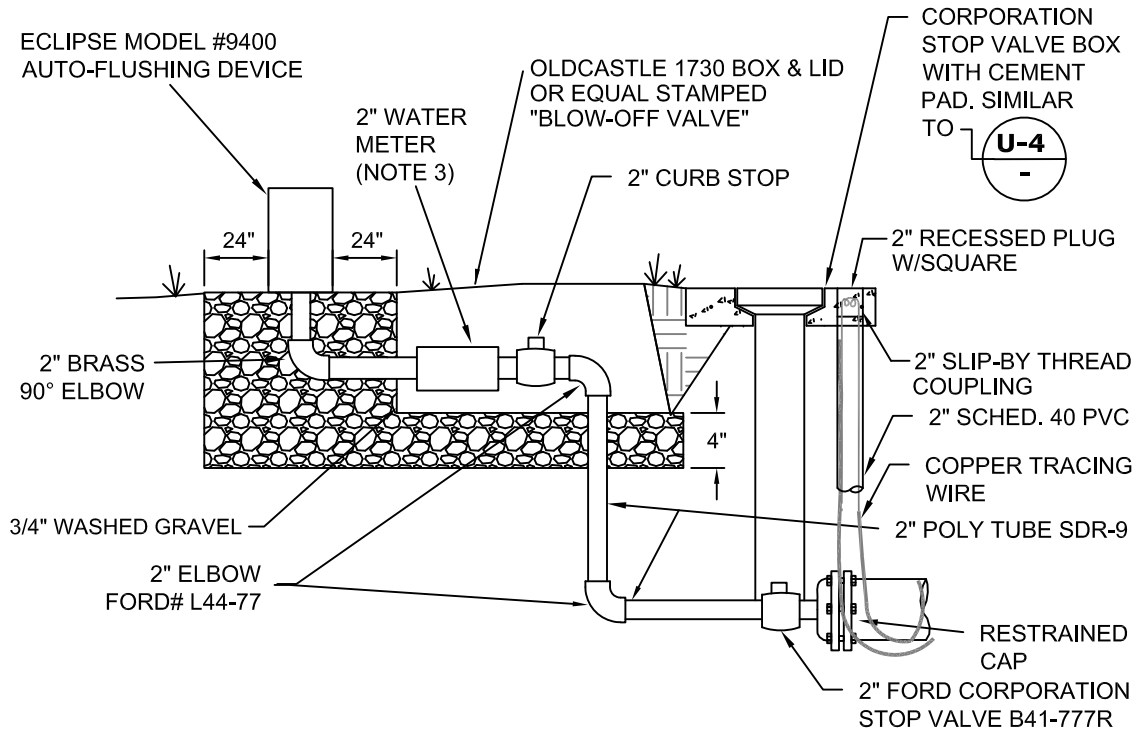

- 1.) FOR ALL DEAD-END WATER MAINS.
- 2.) AUTOMATIC FLUSHING DEVICE SHALL BE AN ABOVE GRADE ECLIPSE MODEL #9400.
- 3.) CONTRACTOR SHALL PROVIDE 2" BADGER MODEL-170 R.R. METER, HRE REGISTER, ORION MESE ENDPOINT.
- 4.) COPPERHEAD TRACING WIRE PART #12 AWG OR EQUAL SHALL BE USED.

## AUTOMATIC FLUSHING DEVICE DETAIL

N.T.S.

**CITY OF VENICE** 401 W VENICE AVE  
VENICE, FL 34285  
ENGINEERING DEPARTMENT (941) 486-2626



**UTILITIES - WATER**

**AUTOMATIC  
FLUSHING DEVICE**

DATE  
JAN 2024

SHEET NO.  
**W-3**

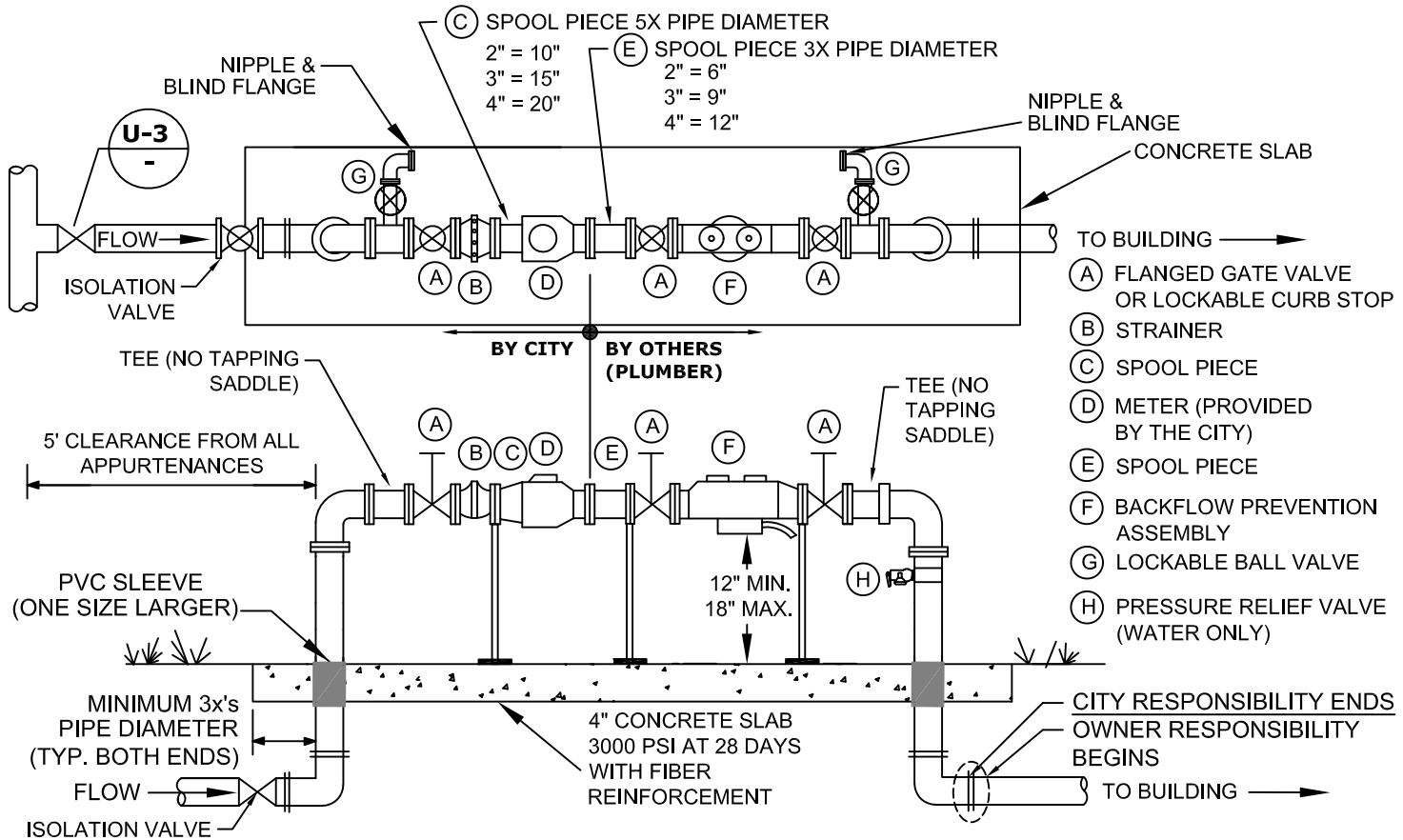

- 1.) EITHER 90°-DEGREE OR 45°-DEGREE FITTINGS MAY BE USED WITH THE REQUIRED LENGTH OF RESTRAINED JOINT FITTINGS.
- 2.) BACKFLOW PREVENTION ASSEMBLY TYPE SHALL BE DETERMINED BY THE CITY OF VENICE UTILITIES DEPARTMENT'S MOST CURRENT CROSS-CONNECTION CONTROL PROGRAM MANUAL (CCM), AND SHALL BE INSTALLED IMMEDIATELY FOLLOWING THE METER. RPZ OR DOUBLE CHECK BFP SHALL BE INSTALLED ABOVE GROUND PER CCM TABLE 3.1.
- 3.) ALL BACKFLOW PREVENTION ASSEMBLIES SHALL BE APPROVED BY THE UNIVERSITY OF SOUTHERN CALIFORNIA FOUNDATION FOR CROSS-CONNECTION CONTROL AND HYDRAULIC RESEARCH AND/OR ASSE 1013.
- 4.) ALL CONCRETE PIPE PENETRATIONS SHALL BE PROTECTED WITH A PVC SLEEVE, ONE SIZE LARGER THAN RISER PIPE.
- 5.) VALVES SHALL BE FULL PORTED FULL FLOW BALL VALVES OR RESILIENT WEDGE OS&Y GATE VALVES.
- 6.) THE BACKFLOW ASSEMBLY SHALL MATCH THE WATER METER SIZE.
- 7.) METERS 1-1/2" AND UP WILL HAVE FLANGES. LAY LENGTHS MUST BE VERIFIED PRIOR TO CONSTRUCTION OF ASSEMBLIES. NO SPOOL PIECE REQUIRED FOR 1 1/2".
- 8.) METERS 1-1/2" AND SMALLER REQUIRE A LOCKABLE CURB STOP.
- 9.) ALL COMMERCIAL AND MULTI FAMILY UNIT METERS MUST BE ABOVE GRADE. REUSE METERS 2" AND LESS MAY BE BELOW GROUND.
- 10.) BACKFLOW PREVENTION ASSEMBLY AND BYPASS ARE NOT REQUIRED FOR REUSE METER.
- 11.) BACKFLOW PREVENTION ASSEMBLIES SHALL ONLY BE BY-PASSED IF A TEMPORARY RP IS INSTALLED ON BY-PASS.
- 12.) NO BRANCH OR TEE SERVICE CONNECTIONS SHALL EXIST BETWEEN THE WATER METER AND BACKFLOW PREVENTER.
- 13.) THE ENGINEER OF RECORD SHALL SUBMIT METER SIZING CALCULATIONS BASED ON SERVICE DEMAND PER AWWA M-22 AND SUBJECT TO APPROVAL BY THE UTILITY DEPARTMENT.
- 14.) PARALLEL BACKFLOW ASSEMBLY MAY BE PERMITTED TO ALLOW FOR UNINTERRUPTED SERVICE AND SHALL PROVIDE THE SAME DEGREE OF PROTECTION OR GREATER.
- 15.) NO PVC SHALL BE PERMITTED ON THE CITY SIDE.

METER SIZE	BY-PASS SIZE
1 1/2", 2"	1"
3", 4"	2"
6"	4"
8"	6"

**REUSE METER, WATER METER, & BACKFLOW PREVENTION ASSEMBLY**  
**ABOVE GROUND METER, 2" & LARGER**  
 N.T.S.

<b>CITY OF VENICE</b> 401 W VENICE AVE VENICE, FL 34285 ENGINEERING DEPARTMENT (941) 486-2626 	<b>UTILITIES - WATER</b>	DATE JAN 2024
	<b>WATER &amp; REUSE METER &amp; BACKFLOW</b>	SHEET NO. <b>W-4</b>

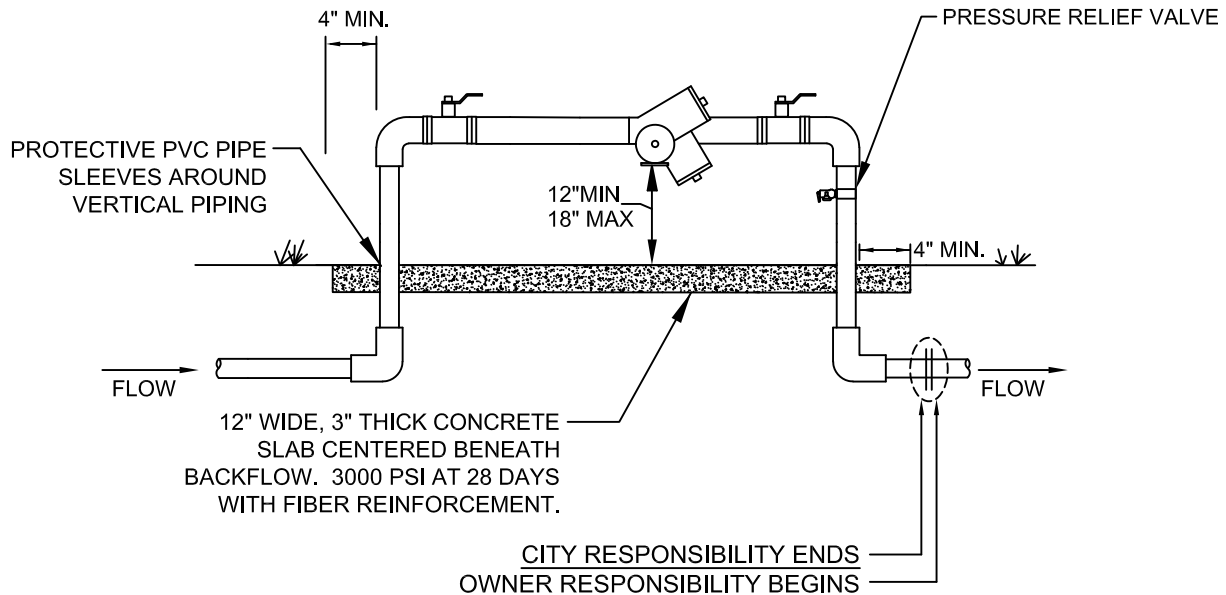

- 1.) BACKFLOW PREVENTION ASSEMBLY TYPE SHALL BE DETERMINED BY THE CITY OF VENICE UTILITIES DEPARTMENT'S MOST CURRENT CROSS-CONNECTION CONTROL PROGRAM.
- 2.) ALL BACKFLOW PREVENTION ASSEMBLIES SHALL BE APPROVED BY THE UNIVERSITY OF SOUTHERN CALIFORNIA FOUNDATION FOR CROSS-CONNECTION CONTROL AND HYDRAULIC RESEARCH AND/OR ASSE 1013.
- 3.) ALL ABOVE GROUND PIPING SHALL BE RIGID COPPER.
- 4.) THE WATER METER AND BACKFLOW PREVENTER SHALL BE THE SAME SIZE.
- 5.) INSTALLED IMMEDIATELY AFTER THE UTILITY WATER METER, PER THE CROSS CONNECTION CONTROL MANUAL, UNLESS OTHERWISE APPROVED IN WRITING BY THE CITY OF VENICE UTILITIES DIRECTOR AND WITH A SIGNED WAIVER AGREEMENT BY THE CUSTOMER.
- 6.) NO BRANCH OR TEE CONNECTIONS SHALL EXIST BETWEEN THE WATER METER AND BACKFLOW PREVENTER.
- 7.) ALL METER BOXES SHALL BE SET FLUSH WITH FINISHED GRADE.
- 8.) SHEETING SHALL BE A PVC TYPE MATERIAL WITH A MINIMUM OF 40 MIL. THICKNESS.
- 9.) PROTECTIVE PIPE SLEEVES SHALL BE PVC PIPE ONE SIZE LARGER THAN RISER OR OTHER CITY APPROVED MATERIAL.
- 10.) PRESSURE RELIEF VALVE SHALL BE INSTALLED.
- 11.) LINE DOWNSTREAM OF METER AND PRIOR TO BACKFLOW SHALL BE POLYETHYLENE.
- 12.) NO PVC SMALLER THAN 4" DIAMETER SHALL BE INSTALLED ON CITY-OWNED UTILITIES.

## ABOVE GROUND BACKFLOW PREVENTION ASSEMBLY

N.T.S.

**CITY OF VENICE** 401 W VENICE AVE  
VENICE, FL 34285  
ENGINEERING DEPARTMENT (941) 486-2626



**UTILITIES - WATER**

**BACKFLOW ASSEMBLY  
(NO MASTER METER)**

DATE  
JAN 2024

SHEET NO.  
**W-5**

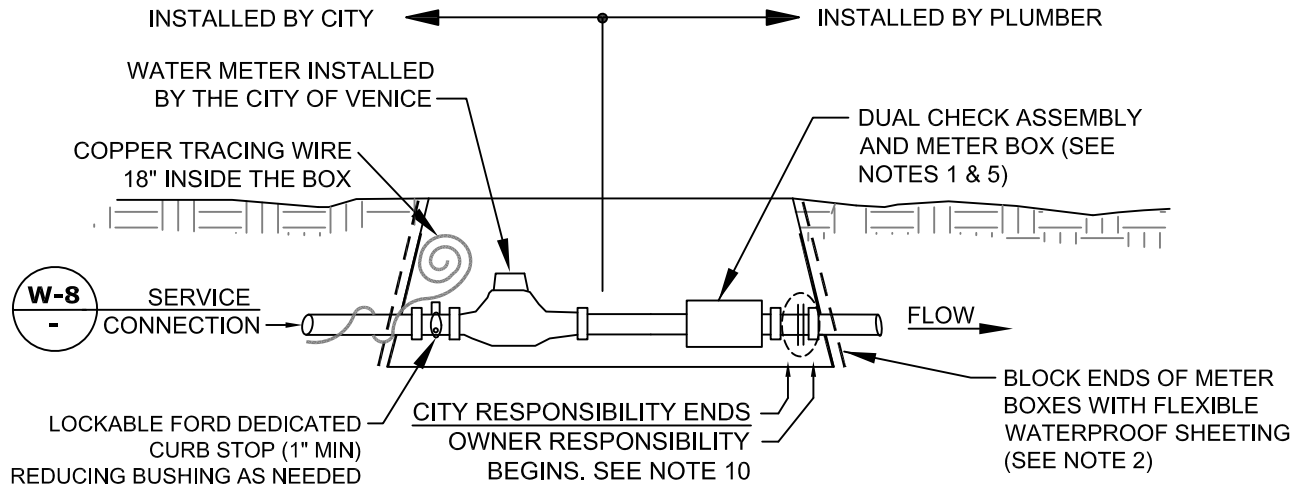

- 1.) THE POTABLE WATER SYSTEM SHALL USE AN OLDCASTLE CARSON MODEL #1220 BLACK PLASTIC METER BOX WITH METAL READER AND BLACK SOLID RODS OR APPROVED EQUAL FOR BOTH METER AND CHECK VALVE. ALL APPURTENANCES MUST FIT AND BE OPERABLE WITHIN METER BOX AS SHOWN.
- 2.) CENTER METER IN BOX AND BLOCK ENDS OF BOX TO PREVENT DIRT FROM ENTERING WITH FLEXIBLE WATERPROOF SHEETING. SHEETING SHALL BE A PVC TYPE MATERIAL WITH MINIMUM 40 MIL THICKNESS.
- 3.) COPPERHEAD TRACING WIRE #12 AWG OR EQUAL SHALL BE USED AND COLOR CODED TO REFLECT WHAT THE PIPE CARRIES (BLUE = WATER).
- 4.) LOCKING CURB STOP MUST BE LOCATED JUST INSIDE BOX AND SHALL BE LOCKED IN THE CLOSED POSITION WITH A LOCK SUPPLIED BY THE UTILITIES DEPARTMENT AT THE TIME OF SERVICE LINE INSTALLATION. LOCK TO BE REMOVED BY THE UTILITIES DEPARTMENT ONLY AFTER STANDARD DETAIL REQUIREMENTS ARE MET. DEDICATED FIRE SERVICE CURB STOPS SHALL BE LOCKED IN THE OPEN POSITION BY THE UTILITIES DEPARTMENT AFTER STANDARD DETAIL REQUIREMENTS ARE MET. ALL CURB STOPS SHALL BE ORIENTED WITH THE OPERATING NUT ON TOP AND ACCESSIBLE FOR SERVICE BY A CURB STOP KEY.
- 5.) DUAL CHECK ASSEMBLY, WILKINS MODEL 700XL FMTC X FNPT WHEN REQUIRED BY THE CITY OF VENICE UTILITIES DEPARTMENT'S MOST CURRENT CROSS-CONNECTION CONTROL PROGRAM, SHALL BE INSTALLED BY A PLUMBER IMMEDIATELY AFTER THE WATER METER IN A SEPARATE METER BOX.
- 6.) RESIDENTIAL FIRE SERVICE SPRINKLERS INCORPORATED INTO DOMESTIC RESIDENTIAL PLUMBING SHALL BE SERVICED BY AN ELECTRONIC WATER METER MEETING NFPA STANDARDS FOR FLOW AND PRESSURE LOSS.
- 7.) THE ENGINEER OF RECORD SHALL SUBMIT METER SIZING CALCULATIONS BASED ON SERVICE DEMAND PER AWWA M-22 AND SUBJECT TO APPROVAL BY THE UTILITIES DEPARTMENT.
- 8.) ALL METER BOXES SHALL BE SET FLUSH WITH FINISHED GRADE.
- 9.) NO PVC SMALLER THAN 4" DIAMETER SHALL BE INSTALLED ON CITY-OWNED UTILITIES.
- 10.) DEDICATED FIRE SERVICES ARE ENTIRELY PRIVATELY OWNED.

## BELOW GROUND RESIDENTIAL WATER & FIRE METER

N.T.S.

**CITY OF VENICE** 401 W VENICE AVE  
VENICE, FL 34285  
ENGINEERING DEPARTMENT (941) 486-2626



**UTILITIES - WATER**

**RESIDENTIAL WATER &  
FIRE METER**

DATE  
JAN 2024

SHEET NO.  
**W-6**



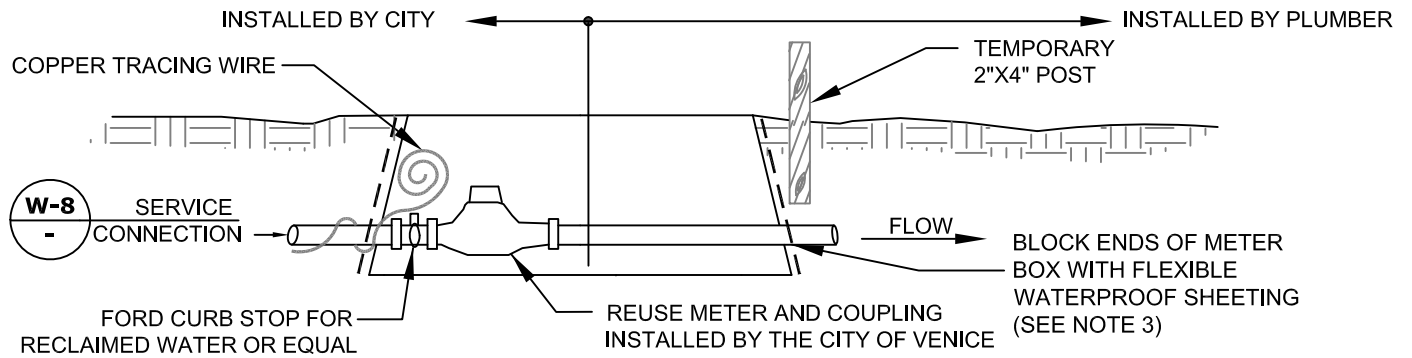

- 1.) THE REUSE SYSTEM SHALL USE AN OLDCASTLE CARSON MODEL #1220 OR APPROVED EQUAL, THE LID SHALL BE STAMPED "NON-POTABLE" & "DO NOT DRINK" IN BOTH ENGLISH AND SPANISH AND MUST BE LOCKABLE, METER BOX AND LID SHALL BE PURPLE (COLOR PANTONE 522C).
- 2.) CURB STOP MUST BE LOCATED INSIDE THE METER BOX AND SHALL BE LOCKED IN THE CLOSED POSITION WITH A LOCK SUPPLIED BY THE UTILITIES DEPARTMENT AT THE TIME OF SERVICE LINE INSTALLATION. LOCK TO BE REMOVED BY THE UTILITIES DEPARTMENT ONLY AFTER STANDARD DETAIL REQUIREMENTS ARE MET. ALL CURB STOPS SHALL BE ORIENTED WITH THE OPERATING NUT ON TOP AND ACCESSIBLE FOR SERVICE BY A CURB STOP KEY.
- 3.) CENTER METER IN BOX AND BLOCK ENDS OF BOX TO PREVENT DIRT FROM ENTERING WITH FLEXIBLE WATERPROOF SHEETING. SHEETING SHALL BE A PVC TYPE MATERIAL WITH MINIMUM 40 MIL THICKNESS.
- 4.) COPPERHEAD TRACING WIRE #12 AWG OR EQUAL SHALL BE USED. IT SHALL BE COLOR CODED TO REFLECT WHAT THE PIPE CARRIES. (PURPLE = REUSE)
- 5.) ALL METER BOXES SHALL BE SET FLUSH WITH FINISHED GRADE.

## REUSE METER

RESIDENTIAL & COMMERCIAL 2" AND BELOW

N.T.S.

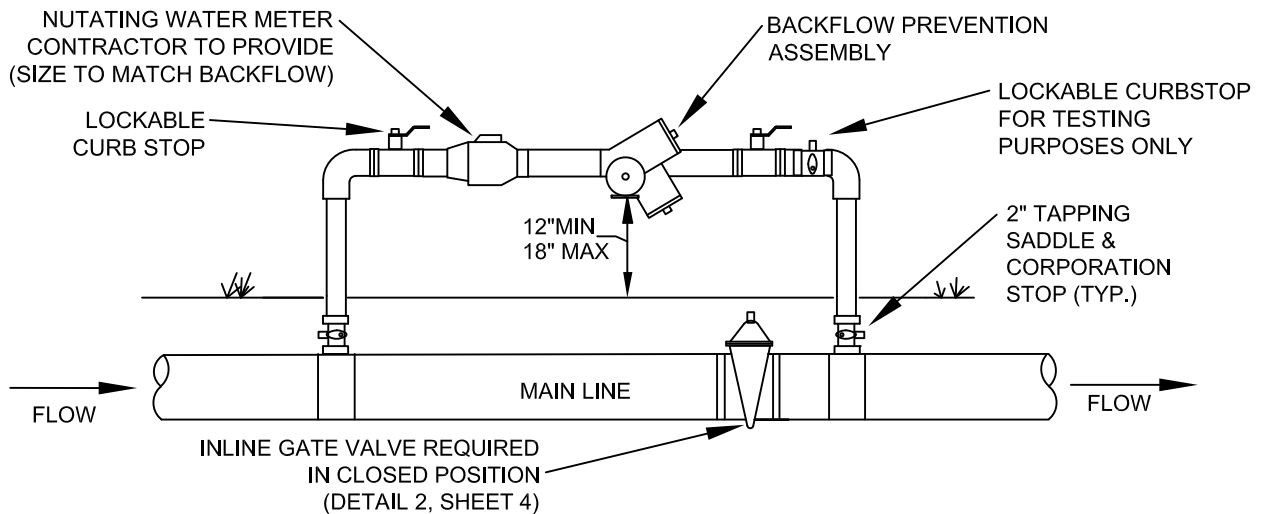

- 1.) REDUCED PRESSURE (RPZ) BACKFLOW PREVENTION ASSEMBLY MUST BE CERTIFIED WITHIN THE PAST YEAR AND A VISIBLE TAG INSTALLED.
- 2.) INLINE MAIN VALVE MUST REMAIN CLOSED UNTIL FINAL CITY TURNOVER IS COMPLETE AND FDEP CLEARANCE IS ISSUED.
- 3.) JUMPER ASSEMBLY SHALL BE REMOVED ONCE MAIN LINE IS CLEARED AND TURNED OVER TO CITY.
- 4.) DURING JUMPER REMOVAL, CORPORATION STOPS SHALL BE SHUT OFF AND PLUGGED WITH LEAD FREE BRASS PLUGS.

## TEMPORARY MAIN-LINE JUMPER DETAIL

N.T.S.

**CITY OF VENICE** 401 W VENICE AVE  
VENICE, FL 34285  
ENGINEERING DEPARTMENT (941) 486-2626



**UTILITIES - WATER**

**REUSE METER &  
TEMPORARY JUMPER**

DATE  
JAN 2024

SHEET NO.  
**W-7**

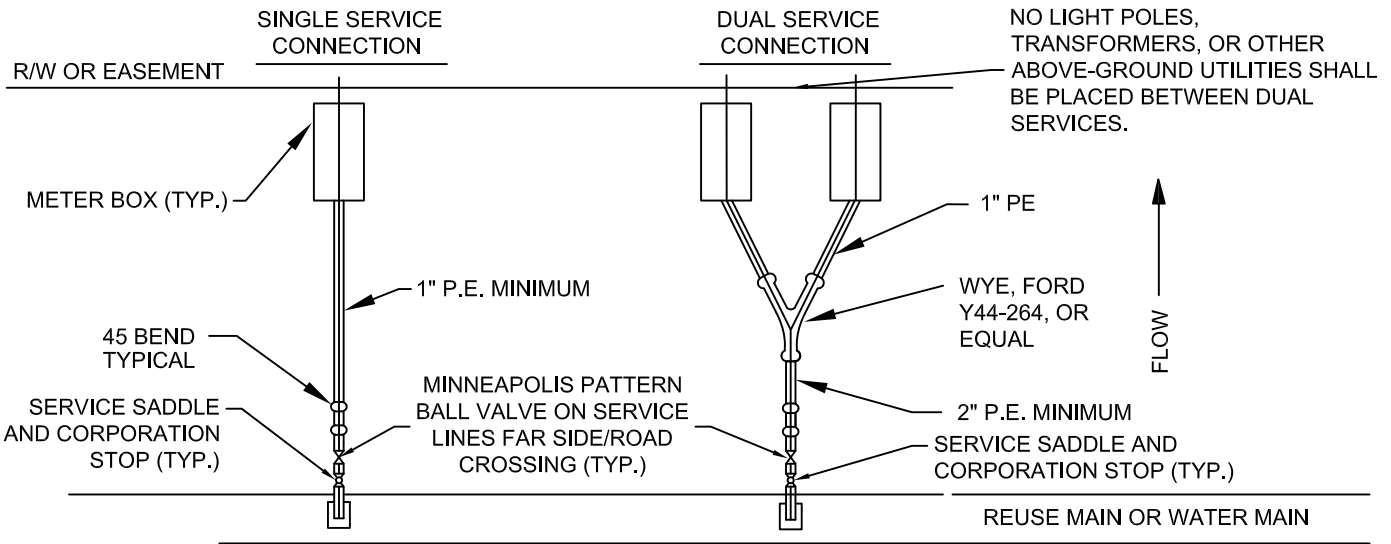

## RESIDENTIAL METER CONNECTION DETAIL

N.T.S.

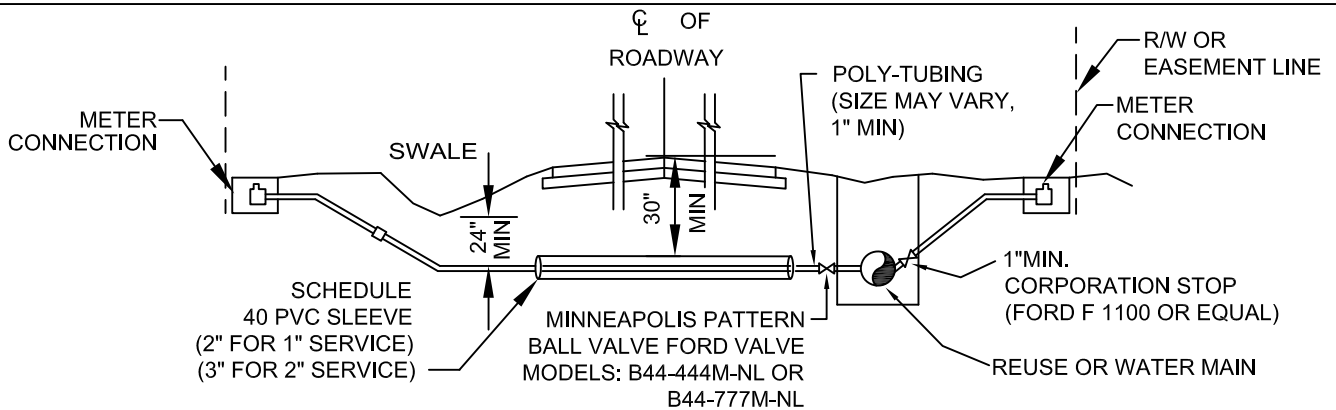

- 1.) TAPS SHALL NOT BE CLOSER THAN TWO FEET APART OR WITHIN TWO FEET OF ANY JOINT.
- 2.) TAPS IN MULTIPLE GROUPS SHALL NOT BE MADE IN THE SAME LONGITUDINAL LINE OF THE PIPE BUT MUST BE STAGGERED VERTICALLY.
- 3.) TAPPING SADDLE SHALL BE STAINLESS STEEL TPS SERIES T3 WITH SS 316 BAND(S) AND HARDWARE, OR BRASS DOUBLE STRAP SERVICE SADDLE WITH BRASS BAND(S) AND HARDWARE.
- 4.) BRASS FITTINGS AND BALL VALVES SHALL BE FORD F1100 OR EQUAL.
- 5.) CITY-APPROVED CURB BOXES SHALL BE USED ON THE MINNEAPOLIS PATTERN BALL VALVE FOLLOWING THE TAPPING VALVE AT THE MAIN, WHEN THE WATER SERVICE CROSSES THE ROAD (FAR SIDE SERVICES), AND THE SERVICE IS 2" OR LESS IN DIAMETER.
- 6.) ALL SERVICES SHALL HAVE COPPER TRACING WIRE FROM MAIN TO METER.
- 7.) ALL SLEEVE ENDS SHALL BE SEALED WITH FOAM SEAL.
- 8.) INSERT STIFFENERS WILL NOT BE ACCEPTABLE.
- 9.) ALL WATERWORKS BRASS MUST BE LEAD FREE.
- 10.) METER SIZE AND SERVICE LINE PIPING DOWNSTREAM OF METER SHALL BE MINIMALLY SIZED BASED ON FIXTURE CALCS AS DETERMINED BY THE EOR.
- 11.) FOR CURBED ROADWAYS: CURB SHALL BE ETCHED WITH THE LETTER "W" FOR WATER SERVICE AND "R" FOR REUSE SERVICE DIRECTLY PERPENDICULAR TO THE METER.

## WATER & REUSE SERVICE CONNECTION

N.T.S.

**CITY OF VENICE** 401 W VENICE AVE  
VENICE, FL 34285  
ENGINEERING DEPARTMENT (941) 486-2626

**UTILITIES - WATER**

DATE

JAN 2024



**RESIDENTIAL METER &  
SERVICE CONNECTION**

SHEET NO.

**W-8**

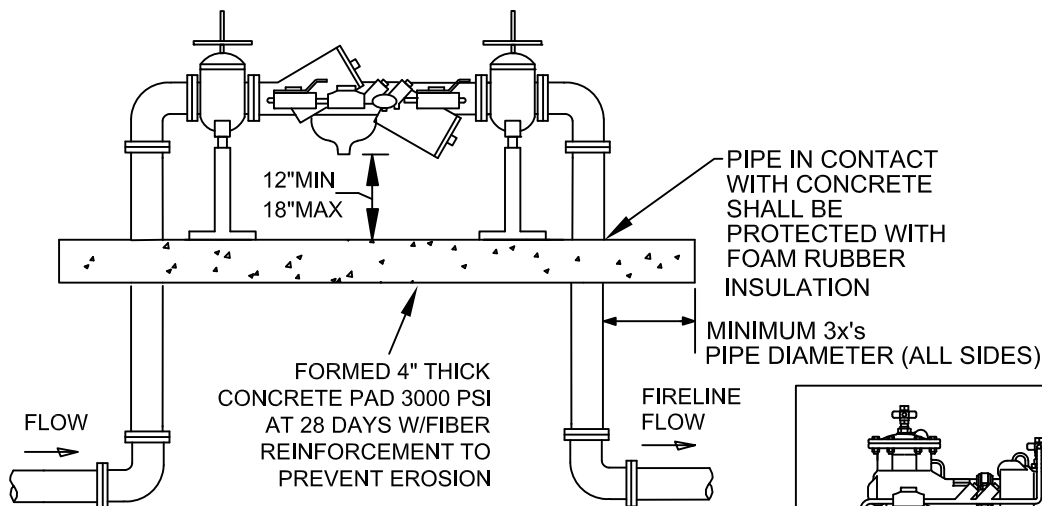

## STANDARD ORIENTATION

## OPTIONAL ORIENTATIONS:

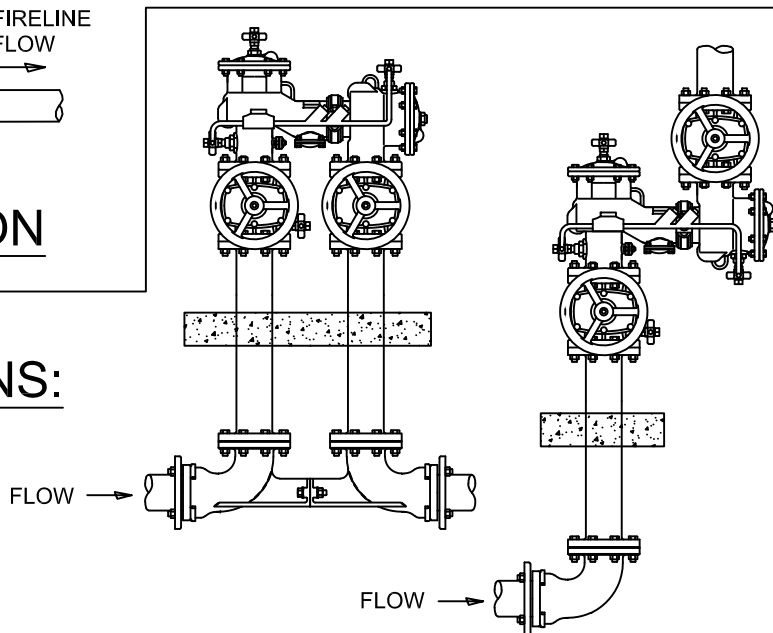

- 1.) ALL BACKFLOW PREVENTION ASSEMBLIES SHALL BE APPROVED BY THE UNIVERSITY OF SOUTHERN CALIFORNIA FOUNDATION FOR CROSS-CONNECTION CONTROL AND HYDRAULIC RESEARCH AND/OR 1047 OR 1048 ASSE AS APPLICABLE
- 2.) 45° FITTINGS MAY BE SUBSTITUTED FOR 90° FITTINGS.
- 3.) PIPE BETWEEN TAP & ISOLATION VALVE SHALL BE C900 PVC OR HDPE.
- 4.) IF TEEING OFF FOR POTABLE SERVICE, INSTALL INDICATOR VALVE BETWEEN TEE FOR POTABLE SERVICE AND FIRE SERVICE BACKFLOW ASSEMBLY.
- 5.) ASSEMBLY SHALL BE PAINTED RED WITH ALKYD ENAMEL, EPOXY OR POLYURETHANE BASED PAINT, EXCEPT FOR STAINLESS STEEL PARTS.
- 6.) VALVE ASSEMBLIES SHALL MEET NFPA 24 REQUIREMENTS AND INDICATOR VALVES SHALL BE PROVIDED.
- 7.) FOR INSTALLATION REQUIREMENTS, PLEASE REFER TO THE CURRENT FLORIDA FIRE PREVENTION CODE.
- 8.) FOR FIRE PROTECTION SYSTEMS EQUIPPED WITH A FIRE PUMP, THE PIPE BETWEEN THE CHECK VALVE AND THE OUTSIDE CONNECTION SHALL BE EQUIPPED WITH AN APPROVED BALL DRIP.
- 9.) BACKFLOW PREVENTION ASSEMBLY TYPE SHALL BE DETERMINED BY THE CITY OF VENICE UTILITIES DEPARTMENT'S MOST CURRENT CROSS-CONNECTION CONTROL PROGRAM.
- 10.) 5" STORZ INLET CONNECTION MAY BE REDUCED FOR PIPE SIZES LESS THAN 5".
- 11.) FIRE SERVICES ARE PRIVATELY OWNED AND MAINTAINED FROM THE TAP OR POINT WHERE THE SYSTEM BECOMES EXCLUSIVELY USED FOR FIRE PROTECTION. THIS INCLUDES THE ISOLATION VALVE OR POSITION INDICATOR VALVE (PIV).

## FIRE SERVICE BACKFLOW ASSEMBLY

SIZE 2" - 10"

N.T.S.

**CITY OF VENICE** 401 W VENICE AVE  
VENICE, FL 34285  
ENGINEERING DEPARTMENT (941) 486-2626



**UTILITIES - WATER**

**FIRE SERVICE  
BACKFLOW ASSEMBLY**

DATE  
JAN 2024

SHEET NO.  
**W-9**

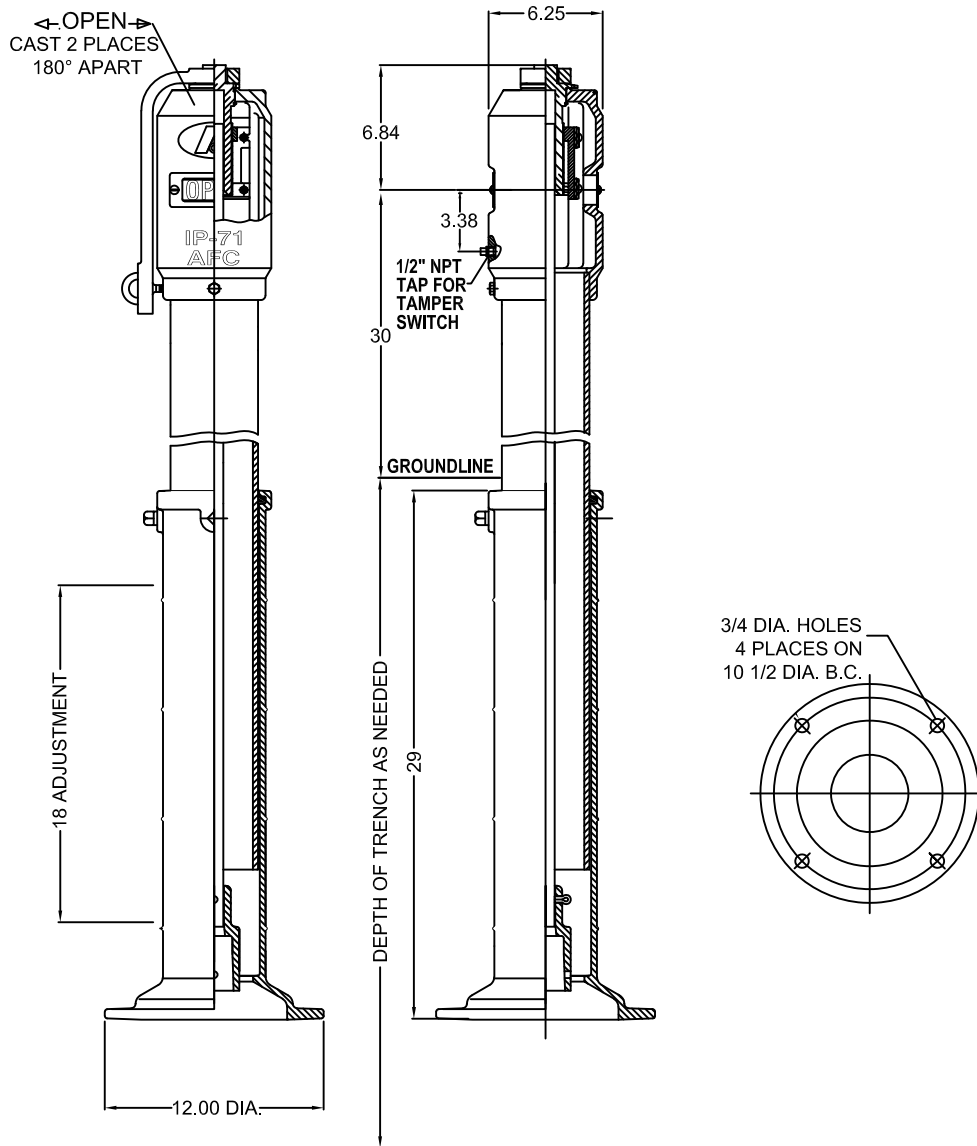

- 1) INDICATOR POST REQUIRED WHEN FIRE SERVICE POINT OF CONNECTION IS ON A POTABLE WATER SERVICE.
- 2) INSTALL INDICATOR POST AND VALVE BETWEEN TEE FOR POTABLE SERVICE AND FIRE SERVICE BACKFLOW ASSEMBLY.
- 3.) AMERICAN FLOW CONTROL IP-71 INDICATOR POST OR EQUIVALENT SHALL BE INSTALLED.
- 4.) UNDERWRITERS LABORATORIES LISTED AND FACTORY MUTUAL RESEARCH APPROVED.
- 5.) FOR USE WITH VALVES WITH O-RING STEM SEALS.
- 6.) ALL EXPOSED EXTERIOR SURFACES COATED WITH TNEMEC 140 EPOXY AND TOP COATED WITH "RED" ENAMEL PER MANUFACTURER'S STANDARD PAINT.

## FIRE SERVICE POST INDICATOR VALVE

N.T.S.

**CITY OF VENICE** 401 W VENICE AVE  
VENICE, FL 34285  
ENGINEERING DEPARTMENT (941) 486-2626



**UTILITIES - WATER**

**FIRE SERVICE  
INDICATOR POST**

DATE  
JAN 2024

SHEET NO.  
**W-10**

# **UTILITIES SEWER DETAILS**

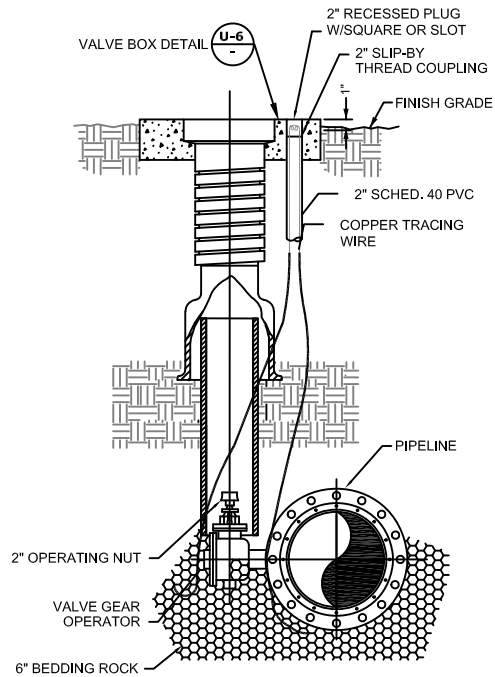

- 1.) PLUG VALVES SHALL BE FULL PORT, MANUFACTURED BY DEZURIK OR APPROVED EQUAL.
- 2.) SEAT OF PLUG VALVE SHALL BE ON THE UPSTREAM SIDE OF THE BODY.
- 3.) VALVE SHALL BE INSTALLED IN CONFORMANCE WITH MANUFACTURER'S RECOMMENDATIONS.
- 4.) ALL SEWER FORCE MAIN PLUG VALVES SHALL BE GEAR OPERATED.

## PLUG VALVE DETAIL

(SEWER FORCE MAINS ONLY)

N.T.S.

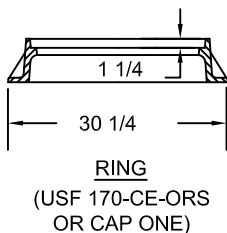
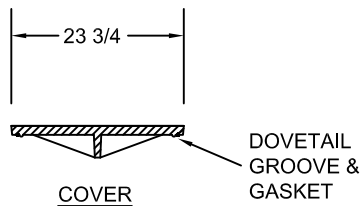

- 1.) MATERIAL: ASTM-A48 CLASS 30B GRAY IRON OR HEAVY DUTY COMPOSITE WITH 316 SS LOCKING BOLTS.
- 2.) RING & COVER WT: APPROX. 150 LBS. EA. (IRON ONLY)
- 3.) INFLOW DISH REQUIRED

### TYPICAL COVER

2 NON PENETRATING PICKHOLES (TYP)



PUBLIC



PRIVATE

- 1.) HEAVY DUTY 130 LB. COVER
- 2.) MANHOLE COVER SHALL BE U.S. FOUNDARY TYPE CE-ORS
- 3.) SHALL BE LABELLED AS ILLUSTRATED ABOVE
- 4.) SHALL BE WATERTIGHT

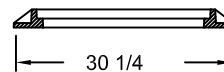

RING  
(USF 580-CE-ORS)

- 1.) MATERIAL: ASTM-A48 CLASS 30B GRAY IRON
- 2.) RING WT: 90 LBS. APP.
- 3.) COVER WT: 130 LBS. APP.

### LOW PROFILE COVER

## MANHOLE COVERS DETAIL

(ALL UNITS IN INCHES)

N.T.S.

**CITY OF VENICE** 401 W VENICE AVE  
ENGINEERING DEPARTMENT VENICE, FL 34285  
(941) 486-2626



**UTILITIES - SEWER**

**PLUG VALVE &  
MANHOLE COVERS**

DATE  
JAN 2024

SHEET NO.  
**S-1**

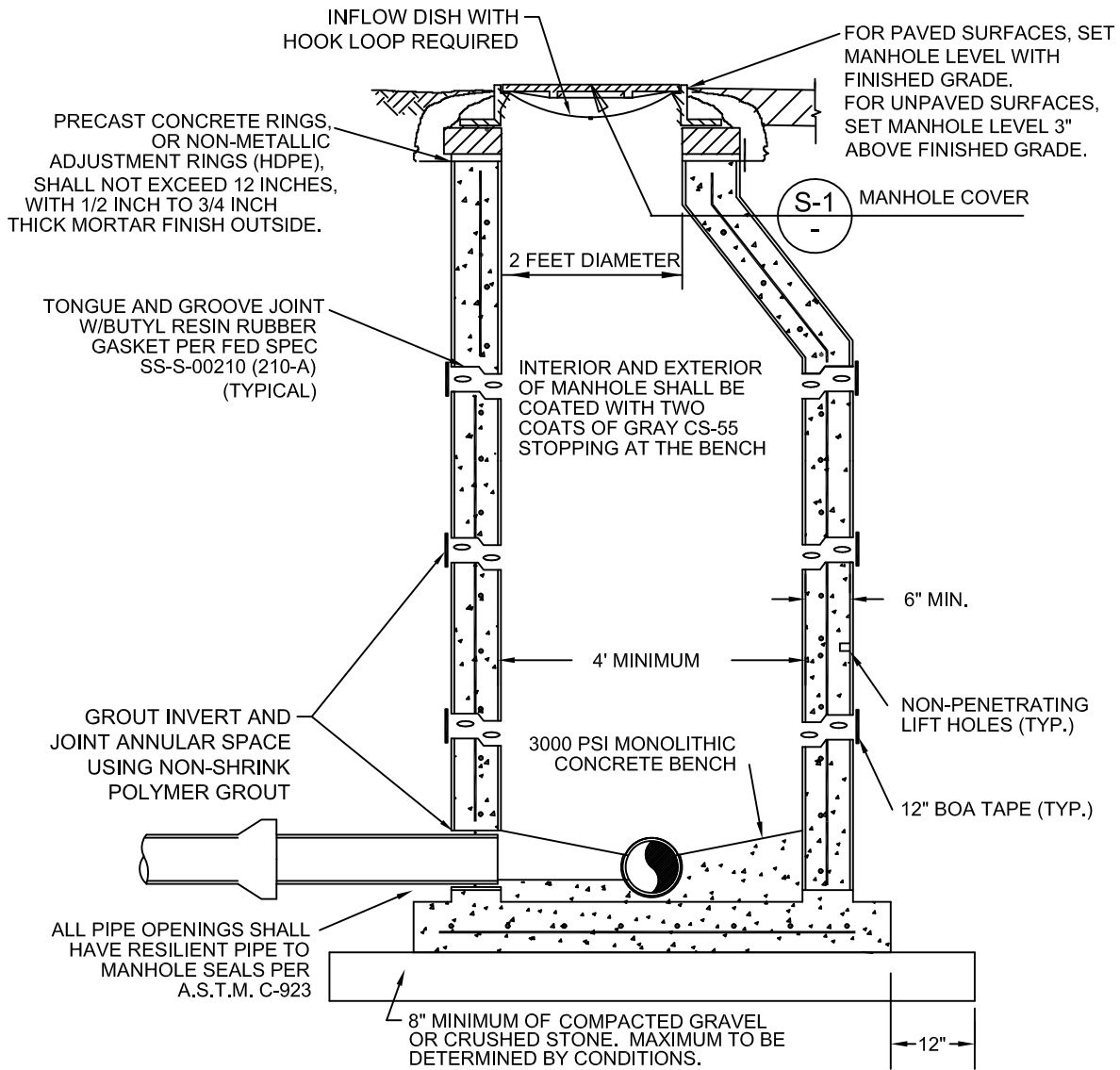

NOTES:

- 1.) MANHOLE SHALL CONFORM TO A.S.T.M. C-478 LATEST REVISION TYPE II CONCRETE, 4000 P.S.I. 28 DAY COMPRESSIVE STRENGTH
- 2.) TURBULENT MANHOLES, DROP MANHOLES, LIFT STATION ISOLATION MANHOLES, AND ALL MANHOLES RECEIVING FORCE MAINS SHALL BE LINED WITH RAVENCOAT 405 EPOXY OR PRECAST WITH HDPE AGRU LINER AND UTILIZE CAP ONE COMPOSITE MANHOLE FRAME AND COVER.
- 3.) ECCENTRIC CONE MANHOLES SHALL BE USED WHENEVER POSSIBLE. WHERE STRUCTURAL CONDITIONS DICTATE, A CONCENTRIC CONE MAY BE USED IN LIEU OF AN ECCENTRIC CONE.
- 4.) FOR MANHOLES LESS THAN 5 FEET IN DEPTH, A SHALLOW MANHOLE (S-3) SHALL BE USED.
- 5.) MONOLITHIC, DUCTILE IRON ADJUSTMENT RINGS MAY ONLY BE USED FOR SURFACE OVERLAY PROJECTS, NOT FOR NEW CONSTRUCTION.
- 6.) INFLOW DISH SHALL BE PROVIDED AND INSTALLED BY CONTRACTOR.

ALL  
CONCRETE  
OR GROUT  
SHALL BE  
NON  
SHRINKING

## SANITARY SEWER MANHOLE DETAIL

N.T.S.

**CITY OF VENICE** 401 W VENICE AVE  
VENICE, FL 34285  
ENGINEERING DEPARTMENT (941) 486-2626



**UTILITIES - SEWER**

**SANITARY SEWER  
MANHOLE**

DATE  
JAN 2024

SHEET NO.  
**S-2**

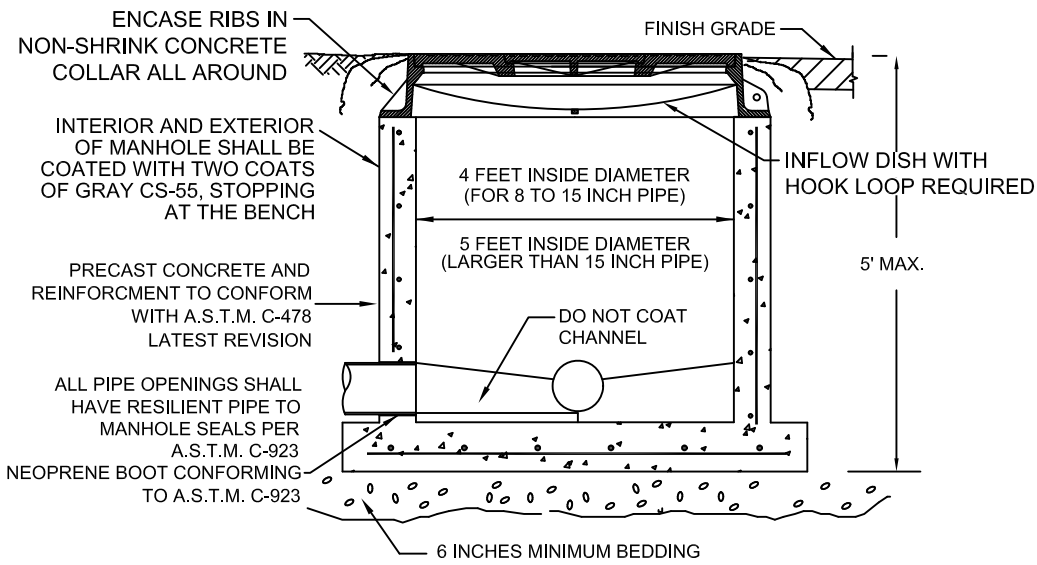

**SHALLOW MANHOLE  
PROFILE**

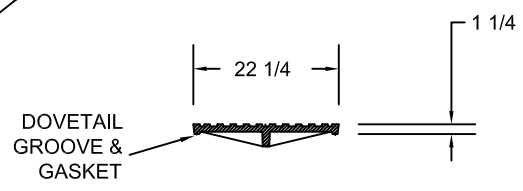

**ACCESS COVER  
PROFILE**

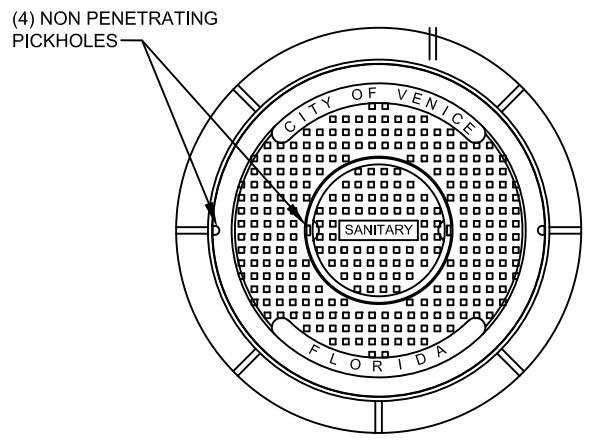

**PLAN**

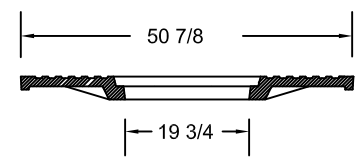

**COVER  
PROFILE**

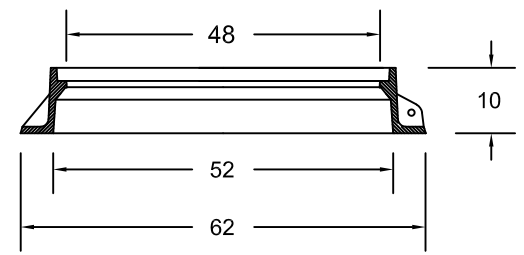

**RING  
PROFILE**

- 1.) SHALLOW MANHOLE SHALL BE INSTALLED WHEREVER THE BASE OF THE MANHOLE IS LESS THAN 5 FEET BELOW THE FINISHED GRADE
- 2.) MANHOLE SHALL CONFORM TO A.S.T.M. C-478 LATEST REVISION TYPE II CONCRETE, 4000 P.S.I. 28 DAY COMPRESSIVE STRENGTH
- 3.) INTERCEPTOR MANHOLES, DROP MANHOLES, AND MANHOLES WITH INTERCEPTING FORCE MAINS SHALL BE LINED WITH RAVEN 405.
- 4.) ALL JOINTS SHALL BE WRAPPED WITH 12" BOA TAPE.
- 5.) INFLOW DISH SHALL BE PROVIDED AND INSTALLED BY CONTRACTOR.
- 6.) COVER SPECIFICATIONS:  
 MATERIAL: ASTM-A48 CLASS 30B GRAY IRON.  
 RING WT: 700 LBS. APP. (USF 690-AG-M)  
 OUTER COVER WT: 675 LBS. APP.  
 INNER COVER WT: 105 LBS. APP.

**PRECAST SHALLOW MANHOLE DETAIL**

N.T.S.

**CITY OF VENICE** 401 W VENICE AVE  
 VENICE, FL 34285  
 ENGINEERING DEPARTMENT (941) 486-2626



**UTILITIES - SEWER**

**PRECAST SHALLOW  
MANHOLE**

DATE  
JAN 2024

SHEET NO.  
**S-3**



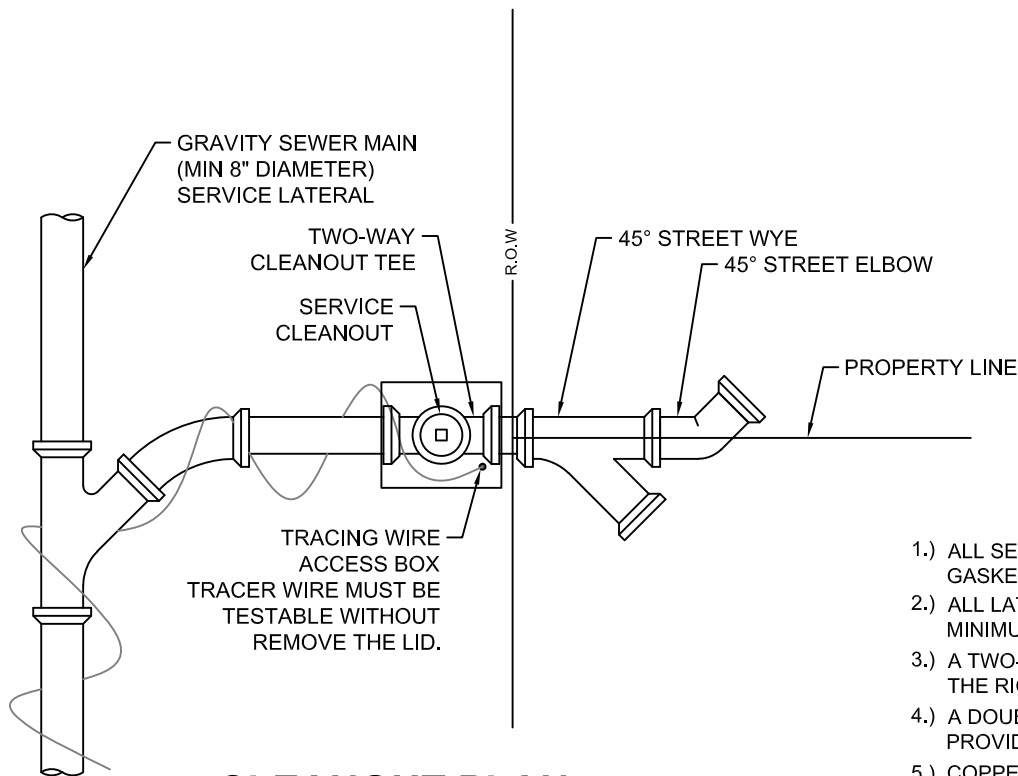

**CLEANOUT PLAN**

TRACING WIRE  
ACCESS BOX  
TRACER WIRE MUST BE  
TESTABLE WITHOUT  
REMOVE THE LID.

- 1.) ALL SERVICE LATERAL JOINTS SHALL BE GASKETED FROM MAIN WYE.
- 2.) ALL LATERAL SERVICES SHALL BE A MINIMUM OF SIX INCHES IN DIAMETER.
- 3.) A TWO-WAY CLEANOUT SHALL BE PROVIDED AT THE RIGHT OF WAY ON THE PROPERTY LINE.
- 4.) A DOUBLE-SWEEP CLEANOUT SHALL BE PROVIDED ON THE PRIVATE SIDE.
- 5.) COPPERHEAD TRACING WIRE #12 AWG OR EQUAL SHALL BE USED. IT SHALL BE COLOR CODED TO GREEN FOR SEWER.
- 6.) AIR TEST REQUIRED.
- 7.) THE BUILDING GENERAL CONTRACTOR SHALL INSURE THE APPLICABLE SERVING SANITARY SEWER CLEANOUT CONNECTION IS PLACED ABOVE FINISHED GRADE WITH COVER, AND IS WITH A CONCRETE PAD AT THE TIME CERTIFICATION OF OCCUPATION (CO) IS REQUESTED. NON COMPLIANCE MAY RESULT IN A DELAY OF CO.
- 8.) FOR CURBED ROADWAYS: CURB SHALL BE ETCHED WITH THE LETTER "S" DIRECTLY PERPENDICULAR TO THE SEWER CLEAN-OUT.
- 9.) WHEN CONNECTING TO EXISTING SERVICE TAPS ON VCP, REMOVE EXISTING VCP WYE AND REPLACE WITH SDR26 GASKETED FITTINGS. USE MAXADAPTOR TO TRANSITION FROM VCP TO PVC. EXISTING INFRASTRUCTURE WITHIN THE PROJECT AREA SHALL BE BROUGHT UP TO CURRENT STANDARDS.

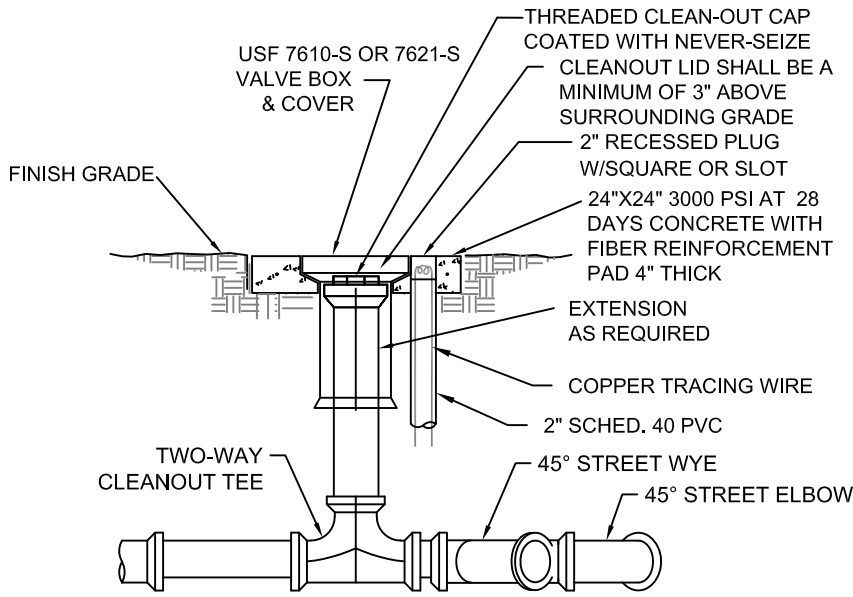

**CLEANOUT PROFILE**

**SANITARY SEWER SERVICE & CLEANOUT DETAIL**

N.T.S.

**CITY OF VENICE** 401 W VENICE AVE  
VENICE, FL 34285  
ENGINEERING DEPARTMENT (941) 486-2626



**UTILITIES - SEWER**

**SEWER SERVICE & CLEANOUT**

DATE  
JAN 2024

SHEET NO.  
**S-4**

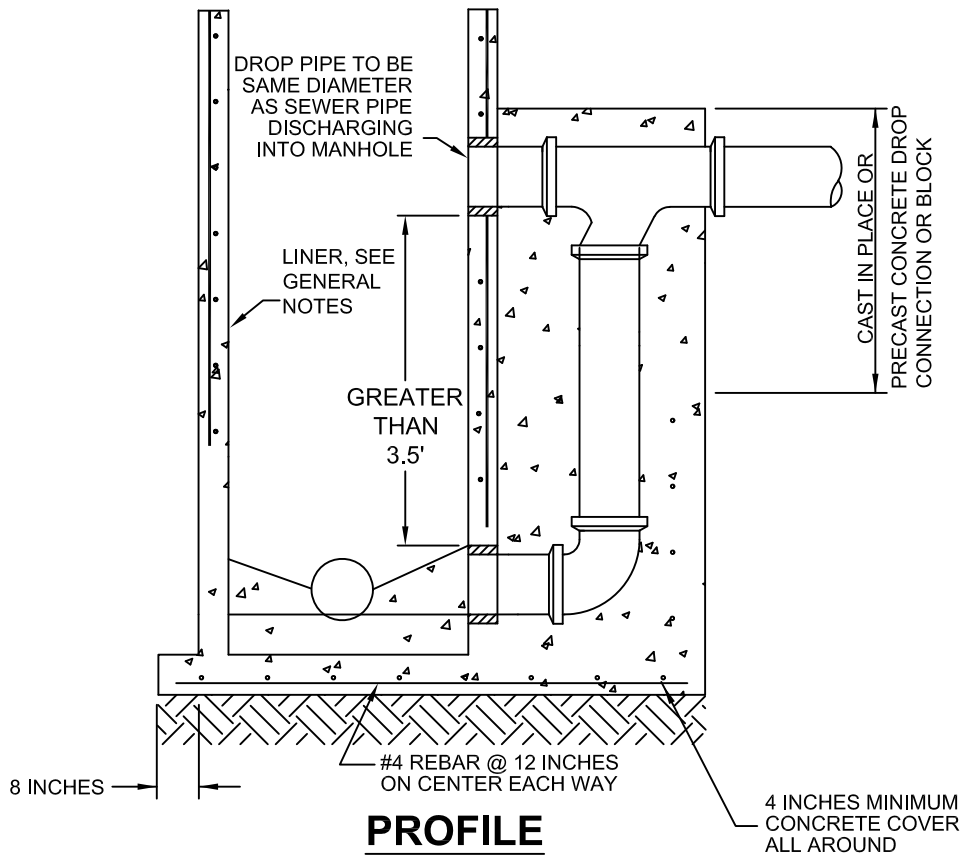

- 1.) MANHOLE SHALL CONFORM TO A.S.T.M. C-478 LATEST REVISION TYPE II CONCRETE, 4000 P.S.I. 28 DAY COMPRESSIVE STRENGTH
- 2.) TURBULENT MANHOLES, DROP MANHOLES, LIFT STATION ISOLATION MANHOLES, AND ALL MANHOLES RECEIVING FORCE MAINS SHALL BE LINED WITH RAVEN COAT 405 EPOXY.
- 3.) DROP MANHOLES SHALL NOT BE USED WITHOUT WRITTEN PERMISSION FROM THE UTILITY DEPARTMENT.

## SANITARY SEWER DROP MANHOLE

N.T.S.

**CITY OF VENICE** 401 W VENICE AVE  
 VENICE, FL 34285  
 ENGINEERING DEPARTMENT (941) 486-2626



**UTILITIES - SEWER**

**SANITARY DROP  
 MANHOLE**

DATE  
 JAN 2024

SHEET NO.  
**S-5**

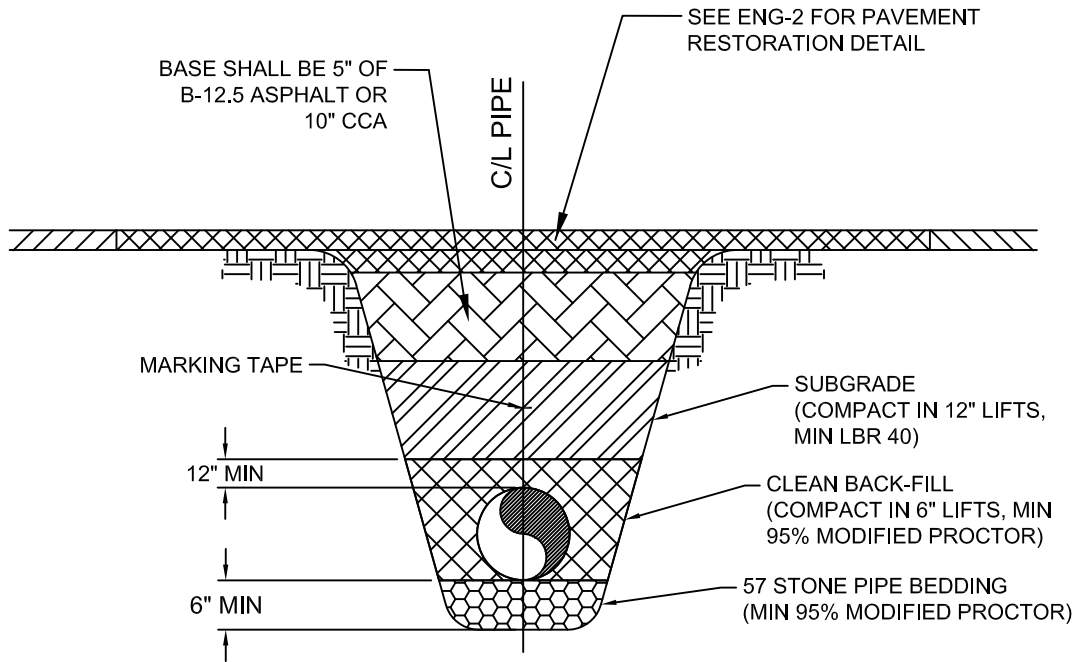

- 1.) MINIMUM COVER SHALL BE 36" FROM TOP OF PIPE TO FINISHED GRADE.
- 2.) INSTALLATION OF PIPE SHALL BE IN CONFORMANCE WITH MANUFACTURER'S RECOMMENDATIONS.
- 3.) PAVEMENT RESTORATION SHALL CONFORM WITH DETAIL ENG-2 OF THESE CITY STANDARDS. FOR NEW CONSTRUCTION, THE FIRST LIFT OF ASPHALT SHALL BE IN PLACE PRIOR TO RECORD DRAWING REVIEW.
- 4.) ALL UTILITIES (PUBLIC AND PRIVATE) THAT CROSS A DITCH / SWALE SHALL BE 36" MIN BELOW THE ACTUAL / DESIGN BOTTOM OF CONVEYANCE.
- 5.) MARKING TAPE SHALL BE PROVIDED PER U-1.

## SEWER PIPE TRENCH DETAIL

N.T.S.

**CITY OF VENICE** 401 W VENICE AVE  
VENICE, FL 34285  
ENGINEERING DEPARTMENT (941) 486-2626



**UTILITIES - SEWER**

**SEWER PIPE  
TRENCH**

DATE  
JAN 2024

SHEET NO.  
**S-6**

**UTILITIES  
LIFT STATION  
DETAILS**

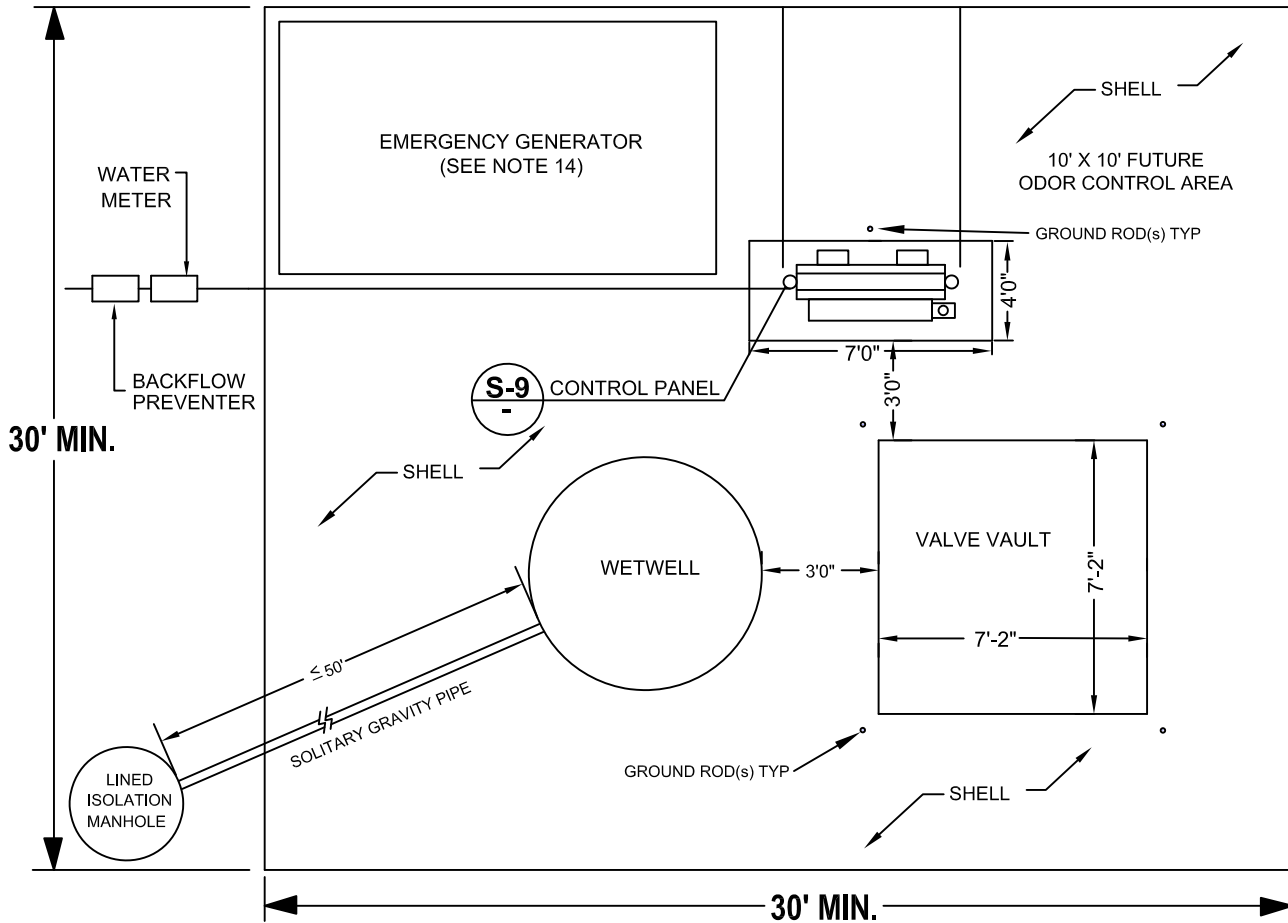

1. UTILITY OWNED LIFT STATIONS SHALL HAVE A MINIMUM DIMENSION OF THIRTY FEET (30') BY THIRTY FEET (30') WITHIN AN "EXCLUSIVE" EASEMENT GRANTED TO THE CITY OF VENICE.
2. THE ENGINEER OF RECORD MUST PROVIDE A LIFT STATION LAYOUT PLAN WHICH INCLUDES DIMENSIONS, EXISTING AND PROPOSED GRADES WHICH DEMONSTRATE POSITIVE DRAINAGE AWAY FROM THE LIFT STATION AND CALCULATIONS VERIFYING NO SITE FLOODING WILL OCCUR DURING THE 25YR, 24 HR STORM EVENT.
3. CONTRACTOR TO PLANT TREES AND SHRUBS SURROUNDING THE LIFT STATION WITH EXCEPTION OF A 12 FOOT ENTRANCE. THE LOCATION OF THE 12 FOOT ENTRANCE SHALL BE APPROVED BY THE UTILITIES DEPARTMENT. TREES & SHRUBS SHALL NOT INTERFERE WITH STRUCTURE, PANELS, ACCESS TO WETWELL OR VALVE VAULT. ALL TREES & SHRUBS SHOULD MATCH SURROUNDINGS SO AS TO MAKE THE LIFT STATION INCONSPICUOUS. THE HOME OWNER ASSOCIATION OR ENTITY RESPONSIBLE FOR COMMON AREA MAINTENANCE IS RESPONSIBLE TO MAINTAIN THE TREES & SHRUBS PLANTED AT LIFT STATION.
4. FENCING MAY BE REQUIRED AT THE DISCRETION OF THE UTILITY DEPARTMENT WHEN IT IS DETERMINED THAT GENERAL PUBLIC SAFETY MAY BE AT RISK OR INCREASED VISUAL BUFFERING IS NECESSARY.
5. CONDUIT CORES IN WETWELL SHALL BE DIRECTED TOWARDS THE CONTROL PANEL TO MINIMIZE DEFLECTIONS.
6. ENTIRE LIFT STATION SITE SHALL BE LINED WITH 2 LAYERS OF VISQUEEN AND WASHED SHELL AT A MINIMUM OF 6" THICKNESS.
7. MINIMUM 12' WIDE ACCESS CONCRETE PAVED DRIVEWAY TO LIFT STATION MUST BE PROVIDED. DRIVEWAY SHALL BE AT LEAST 40' LONG TO ALLOW MAINTENANCE VEHICLES TO PULL ENTIRELY OFF ROADWAY. GATE OPENING SHALL BE A MINIMUM OF 12' CLEAR.
8. AN ADDITIONAL FOUR FOOT WALK-THRU GATE MAY BE REQUIRED.
9. F.P.L. POINT OF CONNECTION (P.O.C.) TO BE ADDED ON AS LOCATED TO L.S. METER CAN.
10. METER CAN TO L.S. P.O.C. LOCATE TO BE ADDED ON REFERENCE DRAWINGS.
11. ALL SPARE PARTS FROM THE SPARE PARTS LIST SHALL BE DELIVERED TO COV UTILITIES DEPARTMENT PRIOR TO ACCEPTANCE OF LIFT STATION.
12. ENGINEER OF RECORD SHALL BE RESPONSIBLE FOR DESIGNING GROUNDING SYSTEM FOR LIFT STATION.
13. EMERGENCY GENERATOR SHALL BE REQUIRED AT ALL LIFT STATIONS UNLESS PRIOR WRITTEN APPROVAL IS GRANTED BY UTILITIES DIRECTOR. ENGINEER TO PROVIDE GENERATOR PAD SIZE AND ELEVATION.

## LIFT STATION SITE LAYOUT

N.T.S.

**CITY OF VENICE** 401 W VENICE AVE  
VENICE, FL 34285  
ENGINEERING DEPARTMENT (941) 486-2626



**UTILITIES - LIFT STATION**

**LIFT STATION  
SITE LAYOUT**

DATE  
JAN 2024

SHEET NO.  
**LS-1**

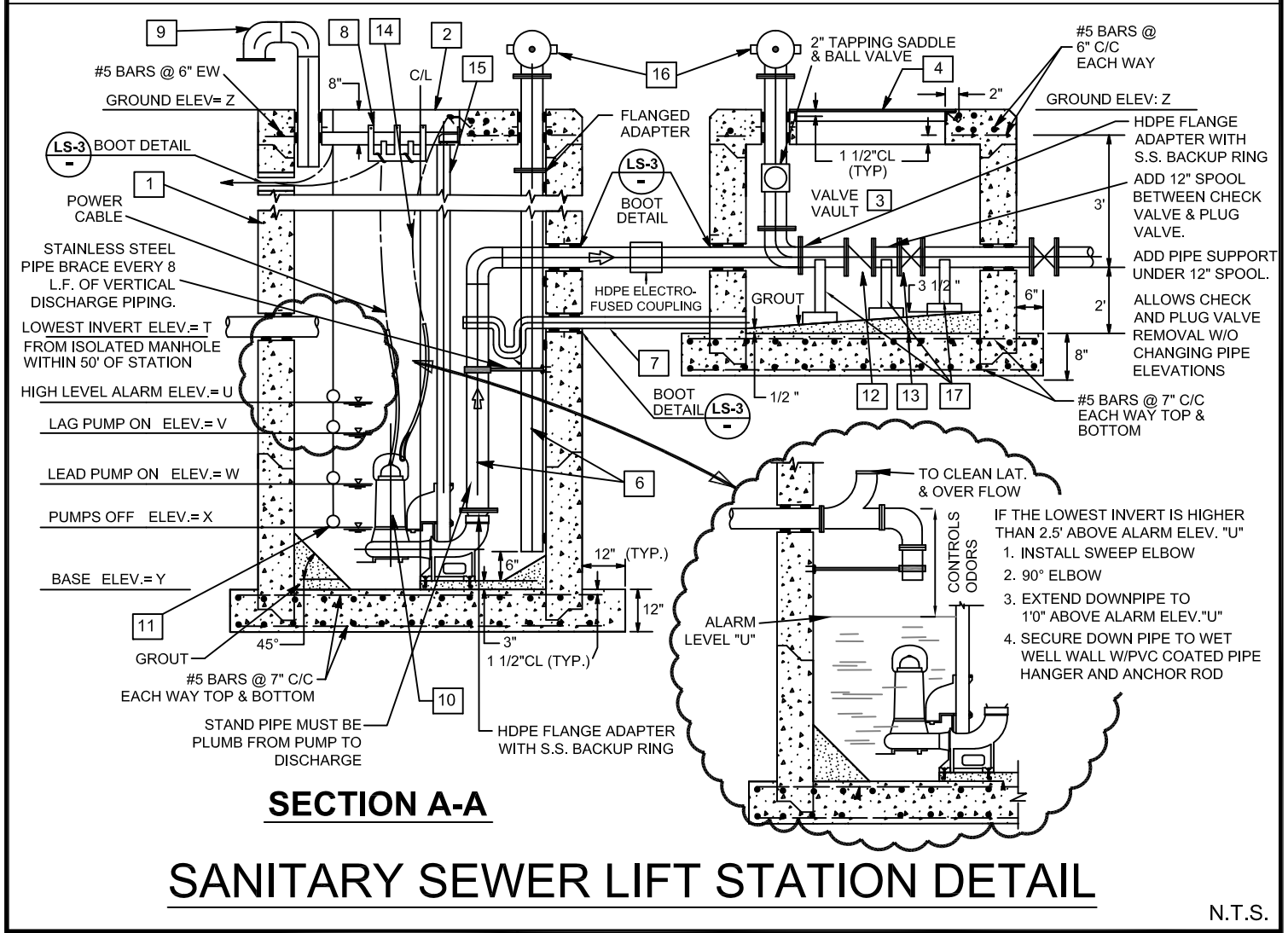
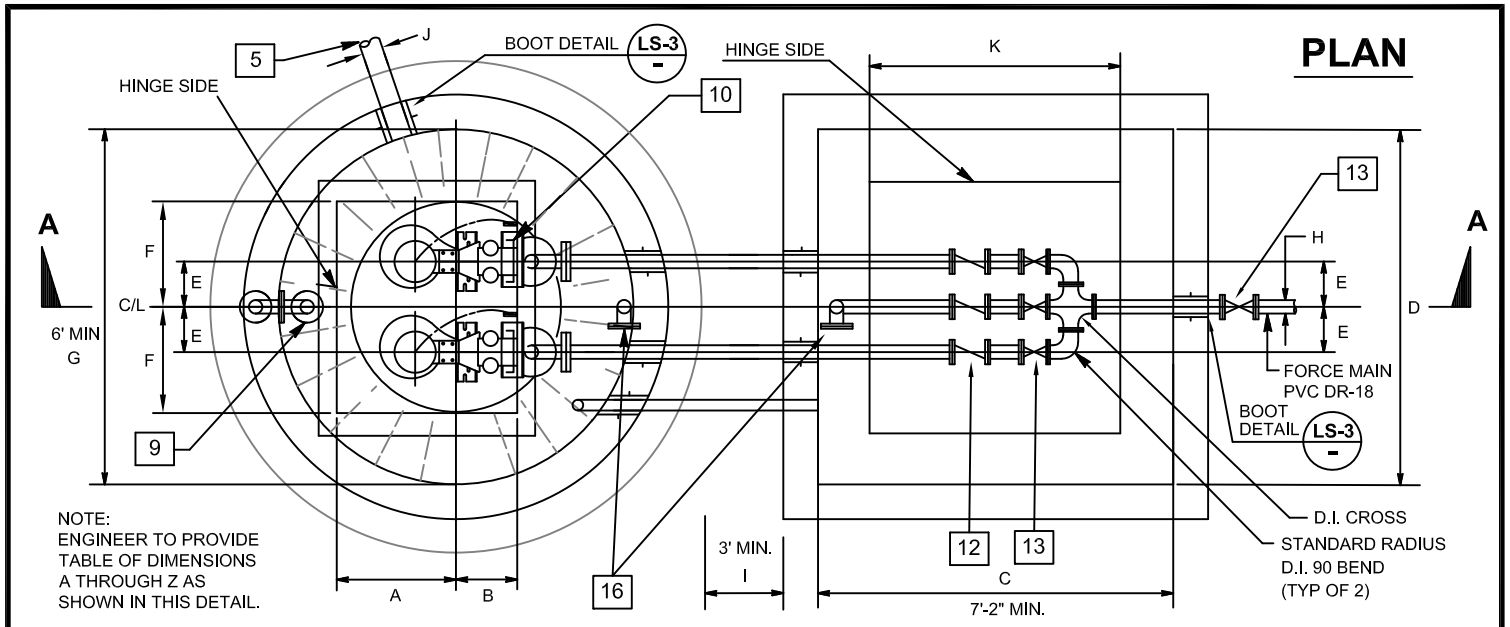

**SANITARY SEWER LIFT STATION DETAIL**

N.T.S.

**CITY OF VENICE** 401 W VENICE AVE  
VENICE, FL 34285  
ENGINEERING DEPARTMENT (941) 486-2626

**UTILITIES - LIFT STATION**

DATE  
JAN 2024

**LIFT STATION**

SHEET NO.  
**LS-2**



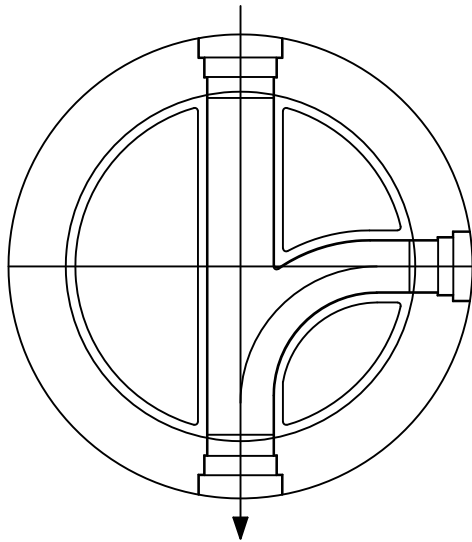

1. BENCHES SHALL BE FIBERGLASS REINFORCED PLASTIC.
2. BASE SHALL BE EXTENDED SKIRT TO FIRST JOINT, AS MANUFACTURED BY GU.
3. NO FIELD MODIFICATIONS TO THE MANHOLE SHALL BE ACCEPTED.
4. INFLOW DISH SHALL BE PROVIDED.

All Interlock Joints  
to be Welded with  
HDPE Strips

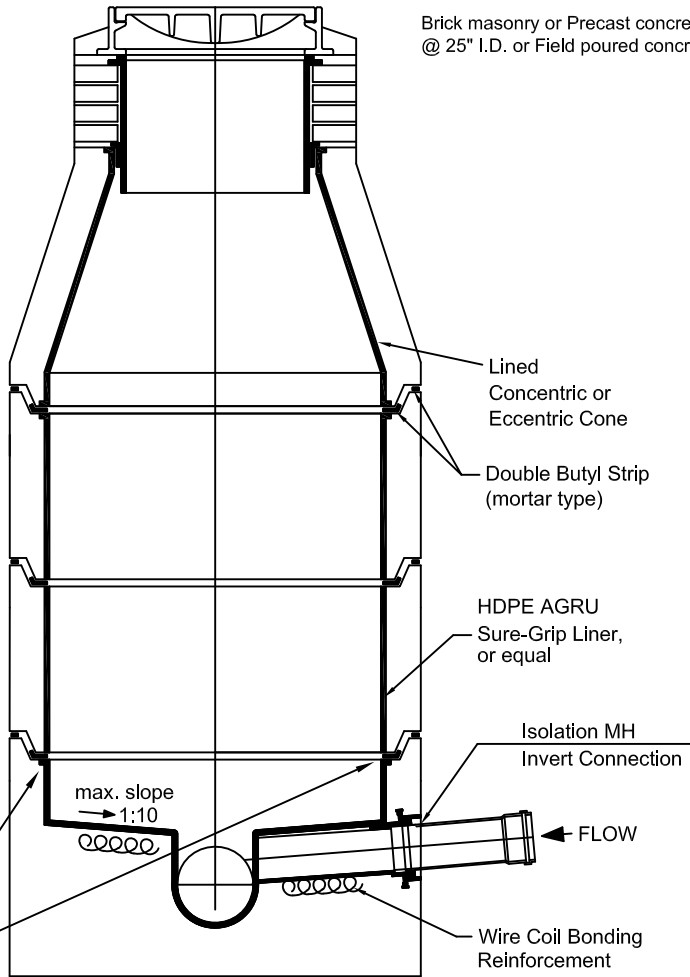

## COMPLETELY LINED ISOLATION MANHOLE DETAIL

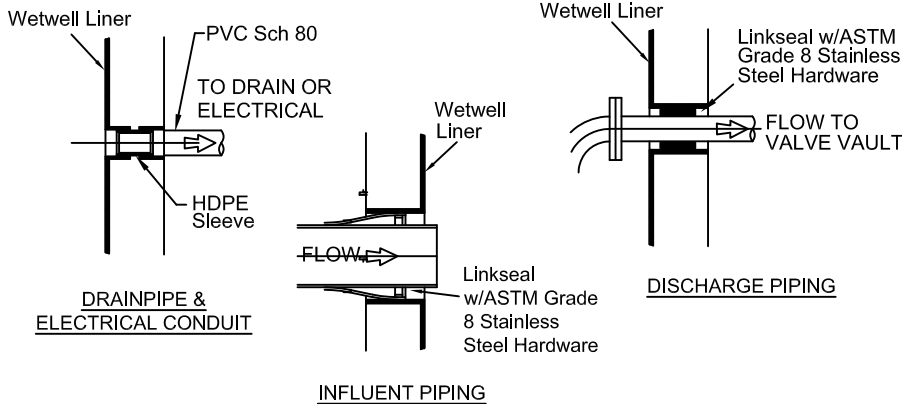

### BOOT DETAILS

N.T.S.

### A-LOCK BOOT OR COMPRESSION GASKET INSTALLATION INSTRUCTIONS

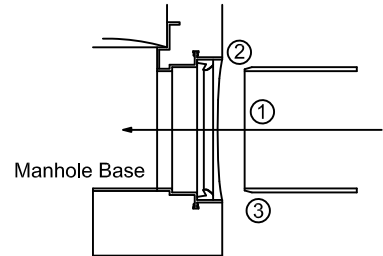

1. CLEAN BELL.
2. INSTALL GASKET AS SHOWN.
3. LUBRICATE SPIGOT AND SLIDE INTO BELL AND GASKET.

### ISOLATION MH INVERT CONNECTION

N.T.S.

**CITY OF VENICE** 401 W VENICE AVE  
VENICE, FL 34285  
ENGINEERING DEPARTMENT (941) 486-2626



**UTILITIES - LIFT STATION**

**ISOLATION MANHOLE  
& BOOT DETAILS**

DATE  
JAN 2024

SHEET NO.  
**LS-3**

Item	Quantity	Description
1	1	<b>WETWELL:</b> Shall be reinforced pre-cast concrete as specified by ASTM C-478, latest revision. Minimum 6-ft. interior diameter. Joints shall be sealed with Butyl seal conforming to federal specification SS-S-00210. Interior shall be lined with HDPE Agru Sure-Grip and welded by an Agru certified welder, or equal. Exterior shall be coated with coal-tar based sealant as manufactured by Concrete Sealants, New Carlisle, Ohio or equal, including the bottom of the slab. All exterior joints shall be wrapped with rubberneck tape. Wetwell shall be set on a minimum base of 6 inches of gravel. A minimum of three 2-inch PVC conduits shall be provided for electrical connections to the motor control panel. All hardware supplied shall be 316 SS. No wetwell shall constructed with a depth greater than 25 ft.
2	1	<b>WETWELL ACCESS HATCH COVER:</b> 2 door access as manufactured by Halliday Products or equal. Access frame and covers shall be fabricated of 1/4 inch aluminum diamond- pattern plate, withstand a minimum live load of 150 psf, and provide support for 316 SS guide rails and 316 SS cable holder for electrical wiring. Covers shall provide lifting handle and safety latch to hold cover in open position. Locking hasps shall be furnished for each cover.
3	1	<b>VALVE VAULT:</b> Shall be pre-cast concrete. All piping shall have 12 inch clearance to floor and walls. Interior and exterior shall be coated with two coats of Koppers Intersol 49 or equal. Install 2 inch 316 SS saddle clamp & ball valve on vertical riser by-pass piping inside of valve vault. All piping entering or exiting the valve vault shall have a rubber boot.
4	1	<b>VALVE VAULT COVER:</b> Shall have a 2-door access as manufactured by Halliday Products or equal. Access frame and covers shall be fabricated of 1/4 inch aluminum diamond-pattern plate and withstand a minimum live load of 150 psf. Each cover shall provide a lifting handle and safety latch to hold cover in open position. Locking hasps shall be furnished for each cover. All hardware supplied shall be 316 SS.
5	1	<b>ISOLATION MANHOLE AND INFLUENT PIPING:</b> Isolation manhole shall be located within fifty (50) feet of the wetwell and discharge through a solitary gravity pipe directly into the wetwell. The isolation manhole walls shall be lined with Agru Sure-Grip; while the manhole invert and bottom shall be lined with a GU/FRP liner or equal. All Interior Seams/Joints to be welded by an Agru certified welder. Isolation manhole shall be located outside of traffic area.
6	1	<b>PIPING:</b> All piping within the wetwell (discharge, standpipe, and vent) shall be DR-11 HDPE with a minimum diameter of four inches. All piping and fittings in the valve vault shall be flanged ductile iron and coated with 2 coats coal-tar epoxy. 1. All force main piping within the wet well and valve vault, from the pump base elbow to the check valve shall be DR-11 HDPE. All connections to iron-bodied flanged fittings in the wet well (pump base ells) shall be made using hdpe flange adapters with 316 stainless steel backup rings. All HDPE connections shall be thermal fused of electro-fused. 2. All metal appurtenances including bolts, nuts and washers inside the wet well and valve vault shall be stainless steel unless otherwise noted (Type 316). All stainless steel bolts shall be treated with never-seize prior to assembly. 3. Vertical HDPE pump discharge pipe in the wet well shall be braced every eight (8) linear feet to prevent excessive bowing. The pipe shall be clamped to a single length of 1-5/8" stainless steel channel installed horizontally and anchored to the wet well wall at each end with a center brace of 1 -5/8" channel attached to the back of the wet well. The pipe clamps shall be a minimum of 1-1/2" wide, 12 ga. stainless steel. Wet wells larger than 8 feet or piping larger than 6 inches shall have bracing constructed from 1/4 inch x 4 inch stainless steel angle.
7	1	<b>VALVE VAULT DRAIN:</b> 2-inch PVC drain with trap. Locate trap to inside of wet well.
8	1	<b>FLOAT CABLE RACK:</b> 316 Stainless Steel (Do NOT install on wall w/invert)
9	1	<b>VENT PIPE:</b> 4-inch Solvent-weld Schedule 80 PVC pipe with stainless steel screen.
10	2	<b>PUMPS:</b> Shall be 240v 3-phase power, submersible-type Hydromatic or ABS, no equal. Pumps shall be a minimum of 100gpm. No vortex or grinder pumps are allowed. A pump curve shall be attached to this set of plans including points of operation or design conditions. Each pump power cable shall have a separate conduit exiting the wetwell and a single additional 2-inch conduit shall be provided for the float control cables. (1 spare pump, same as specs. 1 spare impeller & wear ring for each pump). Impellers shall be 316 stainless steel.
11	4	<b>FLOAT LEVEL SWITCHES:</b> Manufacturer - Anchor Scientific Inc. normally open types control duty float switch Single Throw - Double Pole(STDP) 10 amp @ 120 Vac narrow angle mercury switch Model - S50NO-EZC (Spare set of floats). Do not install on wall with invert.
12	3	<b>CHECK VALVES:</b> Use only valves manufactured by KENNEDY. Valves shall be iron body, bronze-mounted, stainless steel hinge pin, outside lever and weight-operated, swing non-slam type, and equipped with removable inspection covers. Units shall be rated for 150 psi minimum working pressure and shall permit full flow area equal to that of the connecting pipe. All check valves shall have a petcock tapped into the top of the bonnet providing a 1/4-inch NST, female fitting for attachment of a pressure gauge.
13	4	<b>PLUG VALVES:</b> Valves shall be DeZurik. Bodies shall be cast iron per ASTM A 126, Class B. Ends shall be flanged, Class 125 per ANSI B16.1. Plugs shall be cast iron (ASTM A 126, Class B), or ductile iron (ASTM A 536, Grade 65- 45-12) with neoprene facing. Valve body seats shall be 316 stainless steel or have a raised welded-in overlay at least 1/8-inch thick of not less than 90% nickel. Body capscrews and bolts and nuts shall be Type 316 stainless steel. Packing shall be butadiene-filled Teflon and replaceable with valve body under full pressure. Plug valves, 4 inches through 12 inches, shall be non-lubricated type. Minimum pressure rating shall be 175 psi.
14	2	<b>LIFT CABLE:</b> 316 Stainless Steel installed on each pump.
15	1	<b>GUIDE RAILS:</b> 2-inch diameter rails, 316 Stainless Steel, shall be installed plumb from top to bottom, max. 12" from top of lid.
16	1	<b>CAM-LOCK:</b> Ductile iron spool piping with quick disconnect, dust cover, and chain. Position towards by-pass pump access.
17	AS NEEDED	<b>PIPE SUPPORT:</b> Adjustable 316 Stainless Steel pipe support stands in valve vault, minimum seven (7) and shall be coated with 2 coats of coal-tar epoxy. All above ground by-pass piping to be lined epoxy coated ductile iron or DR-11 HDPE.

- Meter fees must be paid in full prior to the lift station start-up.
- Engineer must provide a lift station site plan which includes existing and proposed grades, showing positive drainage away from the lift station.
- If force main discharges into a manifolded system, coordinate with the city of venice utilities department to have one pump operating at each manifolded lift station during time of pump testing.
- Check capacity of pumps by reading motor amp draw and voltage with discharge pressure and rate of flow at three points on the pump curve. Rate of flow and head must be within respectively 10 percent and 5 percent above approved curve for acceptance.
- Float controls shall be submersed to check automatic operation.
- All control panel elements shall be operated during pump testing.
- The pump and control panel manufacturer's representatives shall be present for the initial start-up and testing and shall submit a written report of acceptance to the City of Venice Utilities Department upon successful test results.
- Shop drawings of entire lift station installation must be approved by the City of Venice Engineering and Utility Departments prior to placement of order.

## LIFT STATION SCHEDULE AND NOTES

**CITY OF VENICE** 401 W VENICE AVE  
VENICE, FL 34285  
ENGINEERING DEPARTMENT (941) 486-2626



**UTILITIES - LIFT STATION**

**LIFT STATION  
SCHEDULE**

DATE  
JAN 2024

SHEET NO.  
**LS-4**



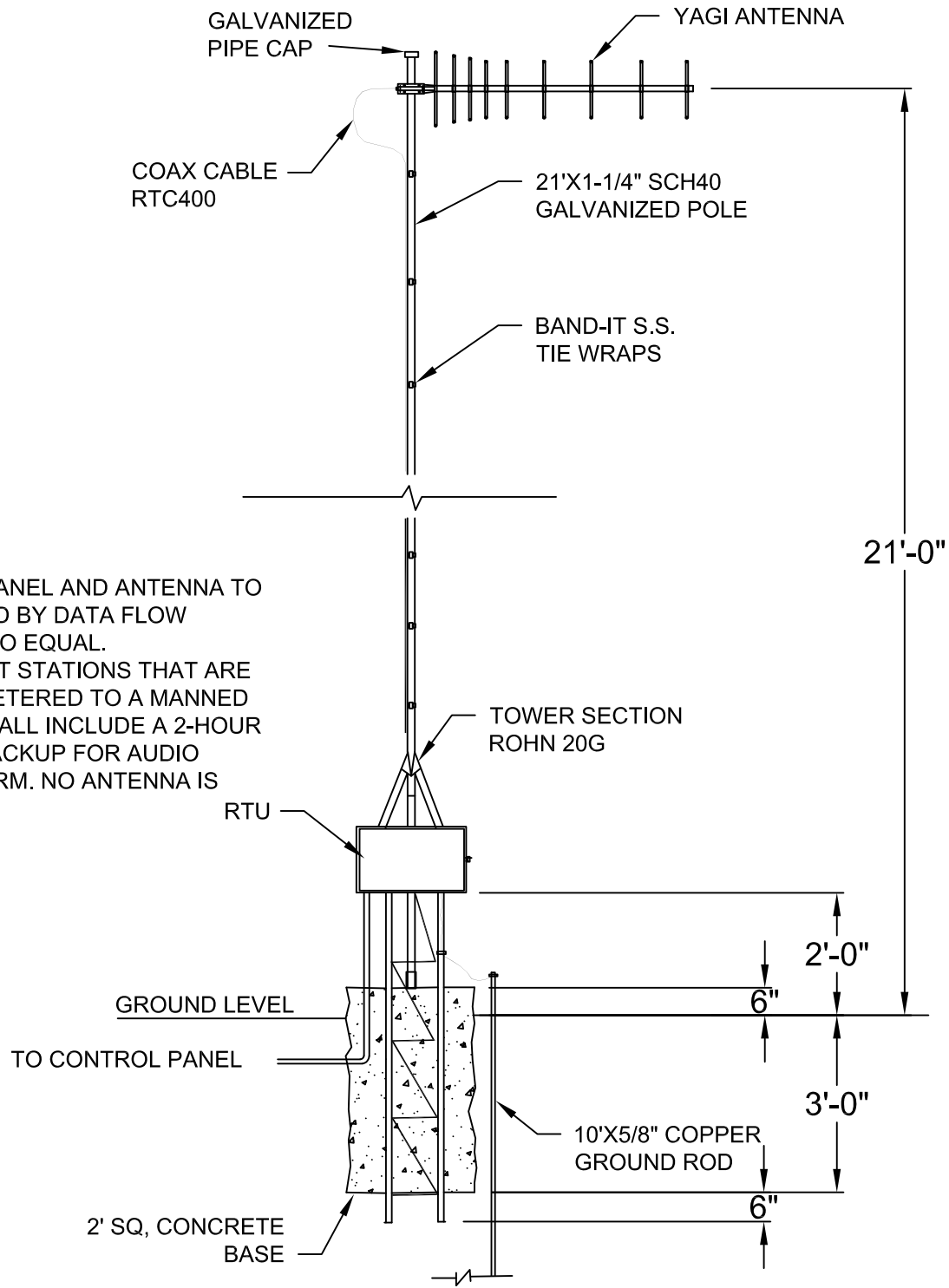

**NOTE:**

1. CONTROL PANEL AND ANTENNA TO BE SUPPLIED BY DATA FLOW SYSTEMS, NO EQUAL.
2. PRIVATE LIFT STATIONS THAT ARE NOT TELEMETERED TO A MANNED FACILITY SHALL INCLUDE A 2-HOUR BATTERY BACKUP FOR AUDIO VISUAL ALARM. NO ANTENNA IS REQUIRED.

## TELEMETRY CONTROL PANEL & ANTENNA

N.T.S.

**CITY OF VENICE** 401 W VENICE AVE  
VENICE, FL 34285  
ENGINEERING DEPARTMENT (941) 486-2626



**UTILITIES - LIFT STATION**

**LIFT STATION  
TELEMETRY**

DATE  
JAN 2024

SHEET NO.  
**LS-5**

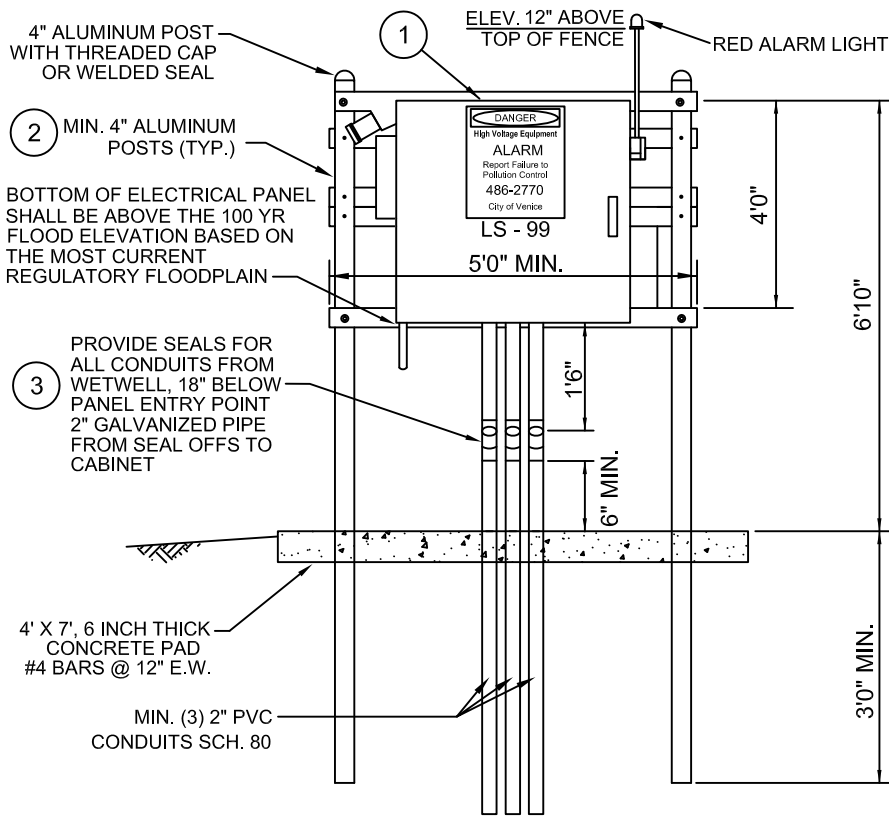

- NOTES:
1. ALL MOUNTING HARDWARE SHALL BE MINIMUM OF 304 STAINLESS STEEL W/ NEOPRENE GASKETS.
  2. ALL WATER SERVICE PIPING SHALL BE 3/4" RIGID COPPER.
  3. ALL PIPING IN CONTACT WITH CONCRETE PAD SHALL BE COATED WITH COAL-TAR EPOXY.

ITEM	QUANTITY	DESCRIPTION
1	1	<p><b>CONTROL PANEL:</b> LOCATION OF THE CONTROL PANEL SHALL CONFORM WITH THE LAYOUT AND ORIENTATION SHOWN WITHIN THIS PLAN SET AND THE CONTROL PANEL SHALL PROVIDE:</p> <ol style="list-style-type: none"> <li>1. TWO (2) MECHANICALLY INTERLOCKED MAIN CIRCUIT BREAKERS (ONE FOR NORMAL POWER, ONE FOR EMERGENCY POWER) SQUARE D TYPE QOU FOR CURRENTS UP TO 100 AMPERES AND TYPE KAL OVER 100 AMPERES.</li> <li>2. EMERGENCY GENERATOR RECEPTACLE (CONFORM TO OTHERS IN SYSTEMS), COMBINATION STARTERS WITH CIRCUIT BREAKERS FOR EACH MOTOR, PLUG-IN ALTERNATOR AND ALTERNATOR TEST SWITCH, CONERY FLOAT CONTROLLERS (LAG PUMP(S) ON AT HIGH WATER LEVEL), HIGH LEVEL ALARM WITH LIGHT, HORN, AND SILENCER SWITCH, CONVENIENCE OUTLET WITH CIRCUIT BREAKER, LIGHTNING ARRESTOR, VOLTAGE/PHASE MONITOR, CONTROL CIRCUIT BREAKER, CONTROL TRANSFORMER (460-VOLT SERVICE ONLY). ALL DEVICES WILL BE LABELED WITH PLACARDS ATTACHED TO DEAD-FRONT DOOR.</li> <li>3. ALUMINUM DEAD FRONT PANEL CONSTRUCTION, NEMA 4X TYPE 304 STAINLESS STEEL RAIN-TIGHT ENCLOSURE WITH DRIP SHIELD, SEAL FAIL MODULE, ELAPSED TIME METER, HOA SWITCH AND RUNNING LIGHTS FOR EACH PUMP. ALL MACHINE SCREWS WILL BE SCREWED INTO PRE-TAPPED THREADS IN THE BACK PANEL; SELF-TAPPING SCREWS OR NUT-SECURED SCREWS ARE UNACCEPTABLE.</li> <li>4. ALL CONDUITS SHALL BE 2-INCH SCHEDULE 80 PVC, EXCEPT FOR THE GROUND CONDUIT, WHICH SHALL BE 1/2-INCH SCHEDULE 80 PVC. ALL CONDUITS SHALL ENTER FROM THE BOTTOM OF THE ENCLOSURES, WITH THE POWER SUPPLY CONDUITS BETWEEN SEAL OFF &amp; PANEL SHALL BE 2" DIA.x18" LONG GALVANIZED PIPE.</li> <li>5. LEVEL CONTROL SYSTEM TO START AND STOP THE PUMPS IN RESPONSE TO WETWELL LIQUID LEVELS. LEAD PUMP ON, LAG PUMP ON, PUMPS OFF, ALARM LEVELS SHALL BE SENSED BY ANCHOR SCIENTIFIC S50NO-EZC ROTOFLOATS SET AT ELEVATIONS WITHIN THE LIMITS DETAILED IN PAGE LS-5.</li> <li>6. ALARM HORN AND GENERATOR RECEPTACLE WITH WEATHERPROOF FITTINGS WITH APPLIED SILICON AROUND PERIMETER OF MOUNTING. THE VISUAL ALARM LIGHT WILL BE MOUNTED WITH A WEATHERPROOF FITTING INTO THE TOP OF ALARM HORN USING 3/4-INCH SS OR ALUMINUM RIGID CONDUIT. THE CONDUIT WILL BE STRAPPED WITH A SS BRACKET WELDED TO THE SIDE OF THE CONTROL PANEL.</li> </ol>
2	1	<p><b>CONTROL PANEL SUPPORT:</b> ALL EQUIPMENT SHALL BE MOUNTED USING 4"x2" ALUMINUM CHANNEL. ISOLATE ALL DISSIMILAR METALS WITH 1/8" NON-METALLIC INSULTING WASHERS. 316 STAINLESS STEEL OR ALUMINUM MOUNTING HARDWARE THROUGHOUT.</p>
3	(AS NEEDED)	<p><b>ELECTRICAL CONDUIT:</b> EACH PUMP POWER CORD AND LOW VOLTAGE SENSOR WILL HAVE A 2-INCH SCHEDULE 80 PVC ELECTRICAL CONDUIT WITH A 2-INCH APPLETON SEAL-OFF 18 INCHES BELOW THE BOTTOM OF THE ENCLOSURE. THE FOUR FLOAT SENSOR CABLES SHALL EACH BE FED THROUGH A 2-INCH SCHEDULE 80 PVC ELECTRICAL CONDUIT WITH A 2-INCH APPLETON SEAL-OFF 18 INCHES BELOW THE BOTTOM OF THE ENCLOSURE, AND SEAL OFF CEMENT W/ DUCT SEAL ON BOTTOM FROM ALL CONDUITS COMING FROM WETWELL.</p>

## LIFT STATION CONTROL PANEL FRONT

N.T.S.

**CITY OF VENICE** 401 W VENICE AVE  
VENICE, FL 34285  
ENGINEERING DEPARTMENT (941) 486-2626



**UTILITIES - LIFT STATION**

**CONTROL  
PANEL FRONT**

DATE  
JAN 2024

SHEET NO.  
**LS-6**

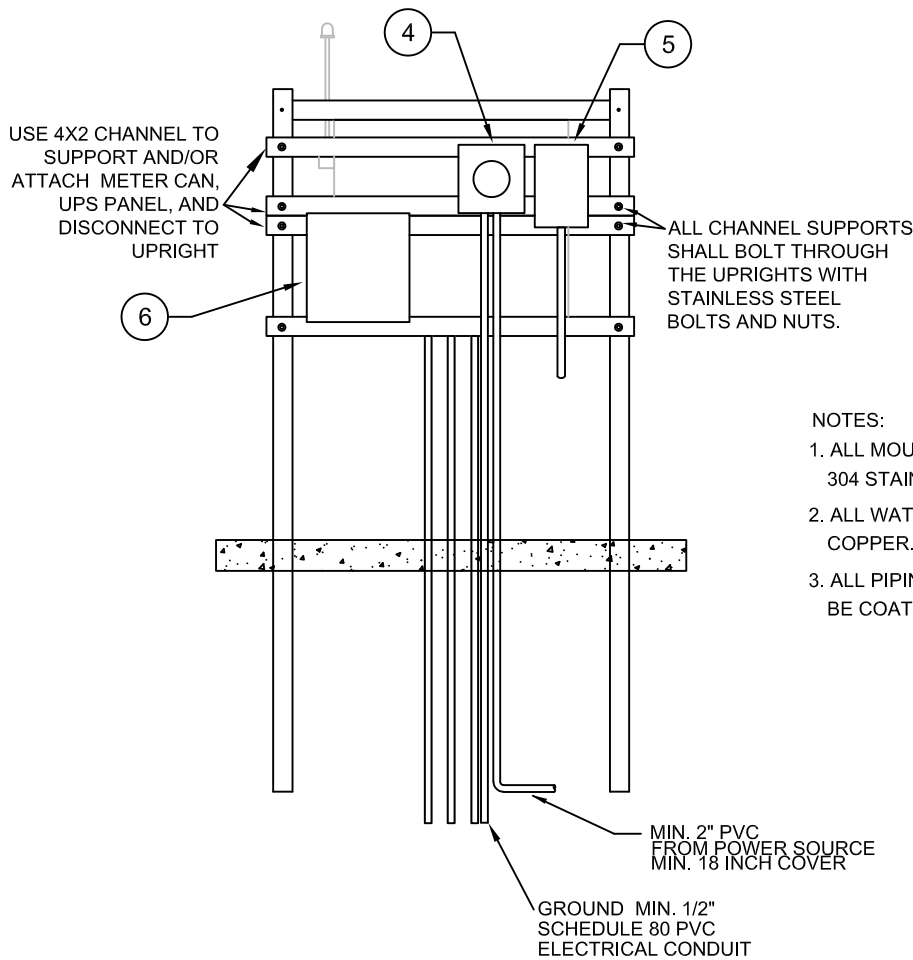

NOTES:

1. ALL MOUNTING HARDWARE SHALL BE MINIMUM OF 304 STAINLESS STEEL W/ NEOPRENE GASKETS.
2. ALL WATER SERVICE PIPING SHALL BE 3/4" RIGID COPPER.
3. ALL PIPING IN CONTACT WITH CONCRETE PAD SHALL BE COATED WITH COAL-TAR EPOXY.

ITEM	QUANTITY	DESCRIPTION
4	1	<b>METER CAN:</b> 200-AMP MILBANK METER CAN WITH BYPASS HANDLE. METER CAN WILL FEED 240 VOLT, 3-PHASE POWER WITH NEUTRAL.
5	1	<b>DISCONNECT SWITCH:</b> SHALL BE NEMA 4X TYPE 304 STAINLESS STEEL, NON-FUSED DISCONNECT SWITCH, PADLOCKABLE IN THE "ON" AND "DOOR-CLOSED" POSITIONS SHALL BE PROVIDED PRIOR TO THE CONTROL PANEL, IN SERIES CONNECTION CONFIGURATION. MIN. 100 AMP SQUARE D TYPE HU 363 DS, SERVICE ENTRANCE RATED. ELECTRIC SERVICE SUPPLY SHALL BE A MINIMUM OF 100 AMPS.
6	1	<b>AUTOMATIC TRANSFER SWITCH:</b> SHALL BE NEMA 4X TYPE 304 STAINLESS STEEL, ASCO 300 G SERIES, 3-POLE, WITH DELUXE EXERCISER.

## LIFT STATION CONTROL PANEL BACK

N.T.S.

**CITY OF VENICE** 401 W VENICE AVE  
VENICE, FL 34285  
ENGINEERING DEPARTMENT (941) 486-2626



**UTILITIES - LIFT STATION**

**CONTROL  
PANEL BACK**

DATE  
JAN 2024

SHEET NO.  
**LS-7**

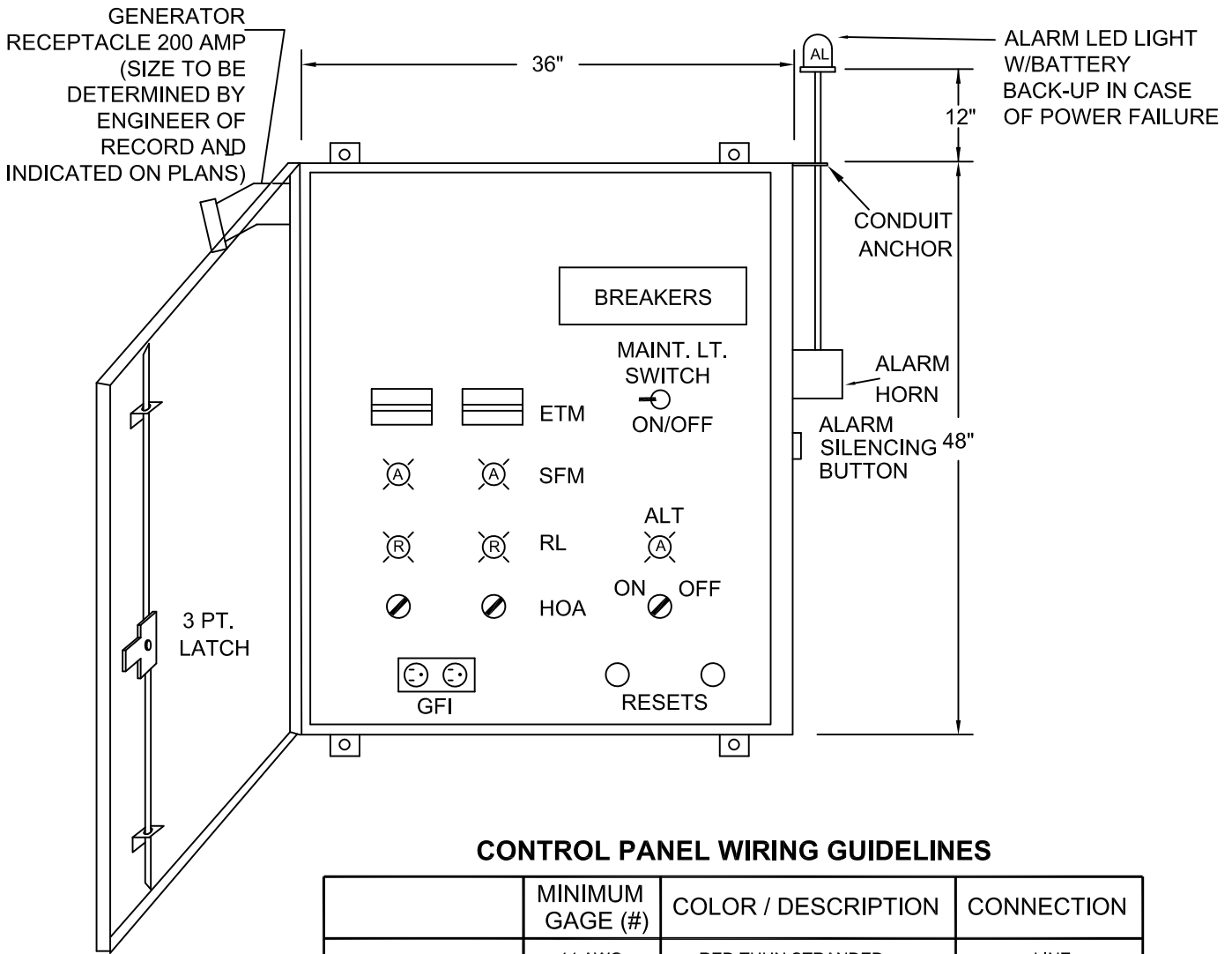

**CONTROL PANEL WIRING GUIDELINES**

	MINIMUM GAGE (#)	COLOR / DESCRIPTION	CONNECTION
CONTROL CIRCUIT	14 AWG	RED THHN STRANDED	LINE
	14 AWG	WHITE THHN STRANDED	NEUTRAL
	14 AWG	GREEN THHN STRANDED	GROUND
ALARM CIRCUIT	14 AWG	BLUE THHN STRANDED	LINE
	14 AWG	WHITE THHN STRANDED	NEUTRAL
	14 AWG	GREEN THHN STRANDED	GROUND
GFI CIRCUIT	12 AWG	BLACK THHN STRANDED	LINE
	12 AWG	WHITE THHN STRANDED	NEUTRAL
	12 AWG	GREEN THHN STRANDED	GROUND

WIRES MUST BE CLEARLY NUMBERED WITH CONSISTENCY AND LABELED WITH WIRE TAGS IN ACCORDANCE WITH THE WIRING SCHEDULE ABOVE.

**ENCLOSURE & DEADFRONT LAYOUT**

N.T.S.

**CITY OF VENICE** 401 W VENICE AVE  
 ENGINEERING DEPARTMENT VENICE, FL 34285  
 (941) 486-2626



**UTILITIES - LIFT STATION**

**ENCLOSURE &  
 DEADFRONT LAYOUT**

DATE  
 JAN 2024

SHEET NO.  
**LS-8**

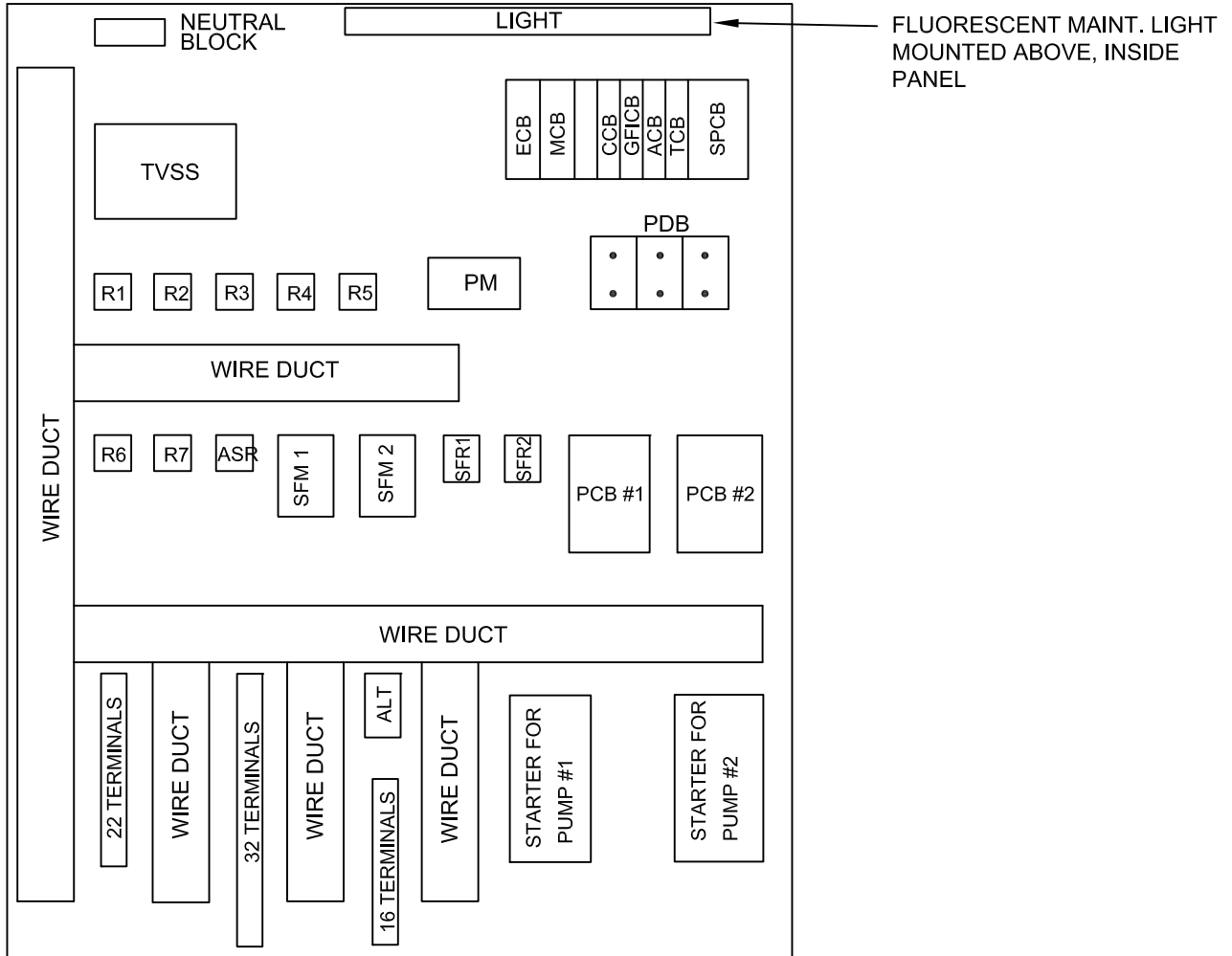

### GENERAL ELECTRICAL NOTES

1. ALL POWER DISTRIBUTION, MOTOR CIRCUIT BREAKERS, MOTOR THERMAL UNITS, AND CROSS-LINE STARTERS WILL BE SIZED PER PUMP MANUFACTURER RECOMMENDATIONS AND NEC.
2. MOTOR STARTERS WILL BE SQUARE D CLASS 8536, OPEN FRAME, AND CROSS-LINE WITH A 120 VOLT COIL AND OVERLOAD BLOCKS. MOTOR STARTERS SHALL BE NEMA SIZE 1, AS A MINIMUM.
3. THE DIVERSIFIED ELECTRONICS PHASE AND VOLTAGE MONITOR WILL DE-ENERGIZE THE 120 VOLT AC CONTROL CIRCUIT AND ENERGIZE THE 120 VOLT AC ALARM CIRCUIT UPON PHASE AND VOLTAGE FAILURE. POWER DISTRIBUTION FOR THE ALARM AND CONTROL CIRCUITS WILL BE DISTRIBUTED FROM DIFFERENT 120 VOLT PHASES. THE PHASE MONITOR WILL AUTOMATICALLY RESET VOLTAGE AND PHASE FAILURES TO NORMAL CONDITIONS ONCE A NORMAL CONDITION IS DETECTED.

## BACKPLATE LAYOUT

N.T.S.

**CITY OF VENICE** 401 W VENICE AVE  
VENICE, FL 34285  
ENGINEERING DEPARTMENT (941) 486-2626



**UTILITIES - LIFT STATION**

**BACKPLATE  
LAYOUT**

DATE  
JAN 2024

SHEET NO.  
**LS-9**

### TERMINALS

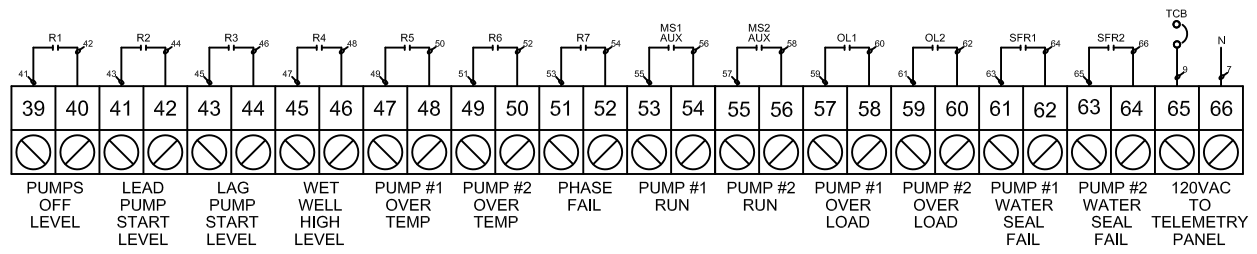
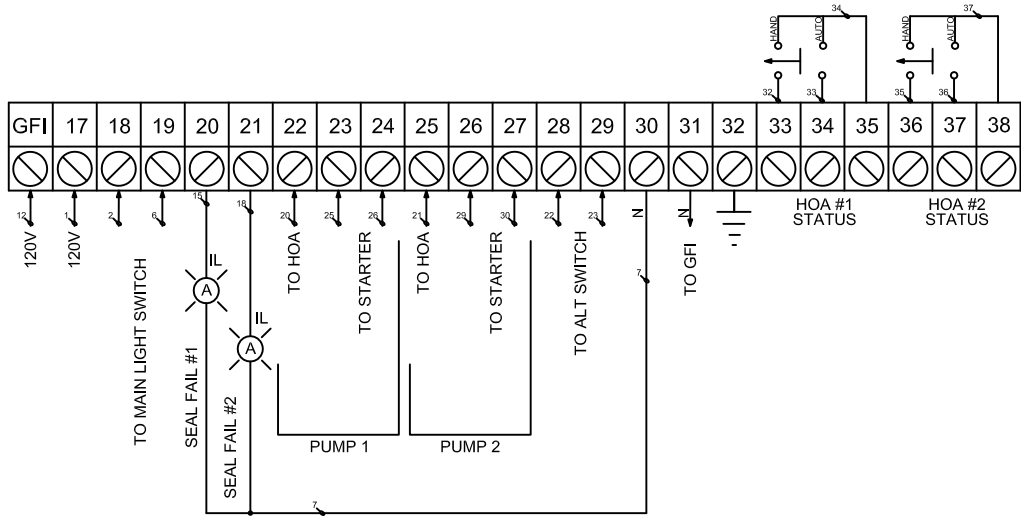
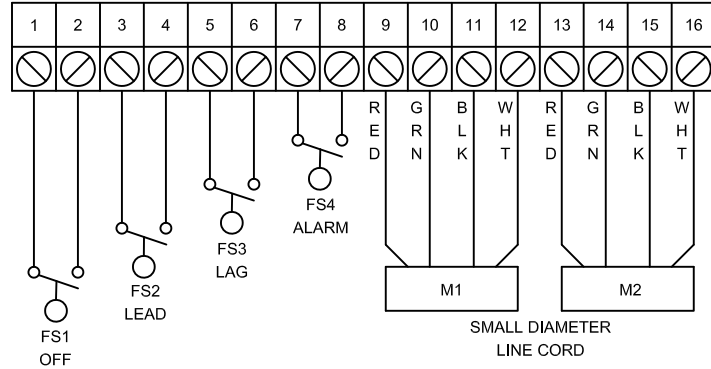

## TERMINAL STRIP DIAGRAM

N.T.S.

**CITY OF VENICE** 401 W VENICE AVE  
 VENICE, FL 34285  
 ENGINEERING DEPARTMENT (941) 486-2626



**UTILITIES - LIFT STATION**

# TERMINAL STRIP DIAGRAM

DATE  
 JAN 2024

SHEET NO.  
**LS-10**

GENERATOR TO  
TRANSFER SWITCH  
AS PER ENGINEER  
OF RECORD/  
MANUFACTURER

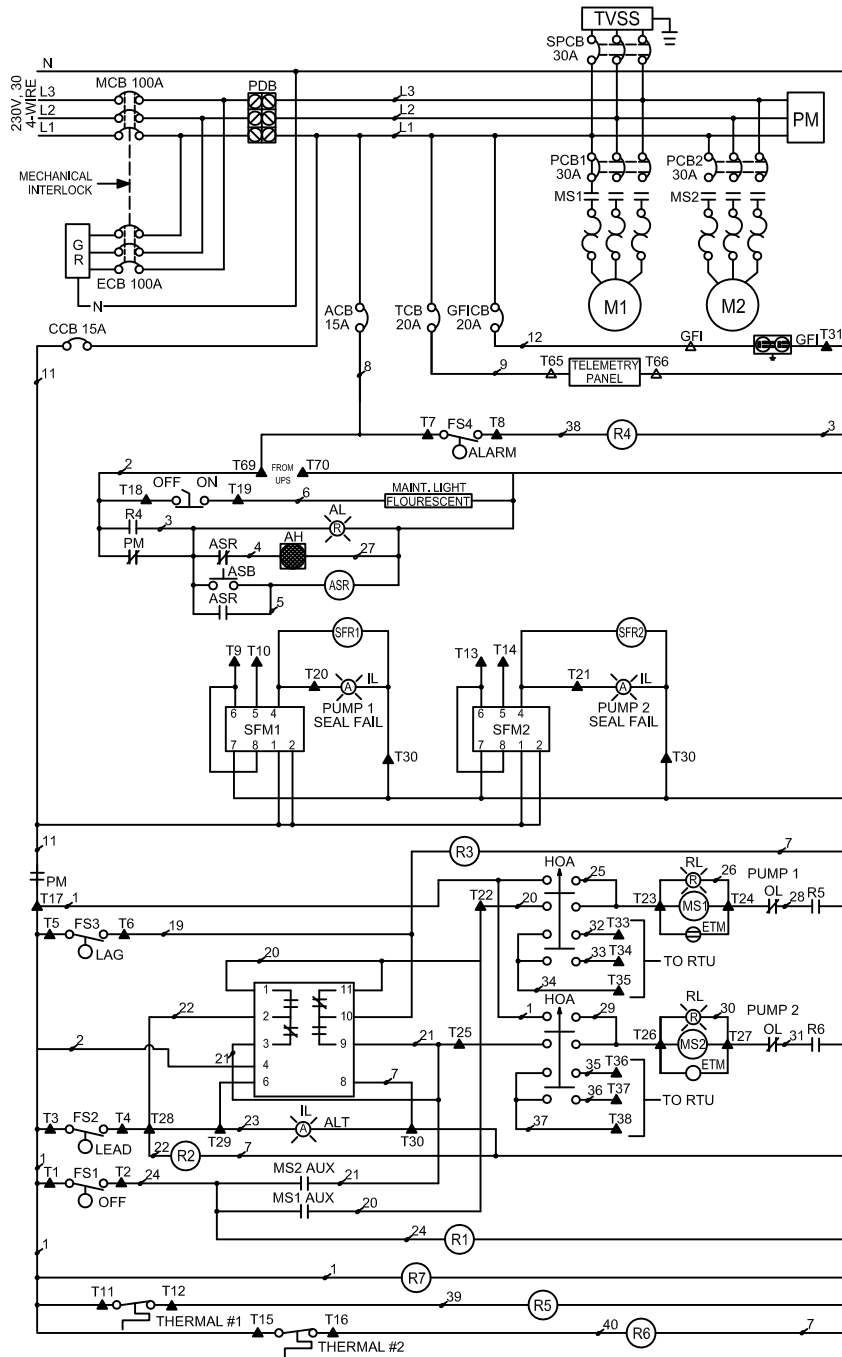

## CONTROL SCHEMATIC DIAGRAM

N.T.S.

**CITY OF VENICE** 401 W VENICE AVE  
VENICE, FL 34285  
ENGINEERING DEPARTMENT (941) 486-2626



**UTILITIES - LIFT STATION**

**CONTROL  
SCHEMATIC DIAGRAM**

DATE  
JAN 2024

SHEET NO.  
**LS-11**

## CONTROL PANEL

### BILL OF MATERIALS

QTY.	ABBR.	DESCRIPTION	MANUFACTURER, PART NO.
1	ENC	ENCLOSURE, 304 S.S. NEMA 3R/12	HOFFMAN, A48H3612SSLP (MIN SIZE) W/3PT LATCH
1	MCB	MAIN CIRCUIT BREAKER	SQ.D, QOU3100*
1	ECB	EMERGENCY CIRCUIT BREAKER	SQ.D, QOU3100*
2	PCB1,2	PUMP CIRCUIT BREAKER	SQ.D, QOU330*
1	SPCB	SURGE PROTECTOR CIRCUIT BREAKER	SQ.D, QOU330
1	CCB	CONTROL CIRCUIT BREAKER	SQ.D, QOU115
1	GFICB	GFI CIRCUIT BREAKER	SQ.D, QOU120
1	ACB	ALARM CIRCUIT BREAKER	SQ.D, QOU115
1	TCB	TELEMETRY CIRCUIT BREAKER	SQ.D, QOU120
2	MS1,2	MOTOR STARTER	SQ.D, 8536 (SIZE 1 MIN.)
6	OL	OVERLOAD HEATER	SQ.D, B 28*
1	GR	GENERATOR RECEPTACLE	RUSSELL STOLL, JR SB1044FR
1	PM	PHASE MONITOR	DIVERSIFIED SLA 230ALA**
2	ETM	ELAPSED TIME METER	SIMPSON, 112ET
1	ALT	ALTERNATOR	DIVERSIFIED ARB-120-ADA
1	AH	ALARM HORN	WHEELLOCK, WHE-31T-115S
1	AL	ALARM LIGHT - STROBE	TOMAR, 495S-120-RED
1	ASR	ALARM SILENCE RELAY	SQ.D, 8501 KP12 V20
1	ASB	ALARM SILENCE BUTTON	SQ.D, 9001 SKR1BH5
1		MAINTENANCE LIGHT SWITCH	SQ.D, 9001 SKS11B5
1		ALTERNATOR SWITCH	SQ.D, 9001 SKS11B5
2	HOA	HAND OFF AUTO SWITCH	SQ.D, 9001 SKS43BH13
2	RL	RUN LIGHT	SQ.D, 9001 SKP1R31
3	IL	INDICATING LIGHT	SQ.D, 9001 SKP1A31
	GFI	GFI RECEPTACLE	HUBBELL, GF20IL
2	SFM1,2	SEAL FAIL MODULE	SSAC, LLC54BA
2	SFR1,2	CONTROL RELAY	SQ.D, 8501 KP12 V20
7	R1 - 7	CONTROL RELAY	SQ.D, 8501 KP12 V20
1	TVSS	SURGE PROTECTOR	INNOVATIVE TECHNOLOGY PTX080 3D101-240-30-N400480-30
1		MAINTENANCE LIGHT (FLUORESCENT)	HOFFMAN, A-LF16M18-R #FS12RC
3		DIN RAIL	ABB, XUS001738

**NOTES:**

- 1) \* = SIZE AS REQUIRED PER HP.
- 2) MIN. #14 AWG THHN
- 3) \*\* = SIZE AS REQUIRED PER VOLTAGE.

**CITY OF VENICE** 401 W VENICE AVE  
VENICE, FL 34285  
ENGINEERING DEPARTMENT (941) 486-2626



**UTILITIES - LIFT STATION**

**CONTROL PANEL  
BILL OF MATERIALS**

DATE  
JAN 2024

SHEET NO.  
**LS-12**



## UPS PANEL

BILL OF MATERIALS			
QTY.	ABBR.	DESCRIPTION	MANUFACTURER, PART NO.
1	ENC	ENCLOSURE, 304 S.S. NEMA 3R/12	CUSTOM EQUIPMENT, 24X20X10-SL
1	FAN	COOLING FAN	HOFFMAN, A-4AXFN
1	T-STAT	THERMOSTAT	PFANNENBERG, FLZ530
1	F1	FUSE	FERRAZ, TRM-3
1	SR	UPS RECEPTACLE	PHOENIX CONTACT, 2963860

**NOTES:**

- 1) \* = SIZE AS REQUIRED PER HP.
- 2) MIN. #14 AWG THHN
- 3) \*\* = SIZE AS REQUIRED PER VOLTAGE.

## SPARE PARTS

BILL OF MATERIALS			
QTY.	ABBR.	DESCRIPTION	MANUFACTURER, PART NO.
1	MCB	MAIN CIRCUIT BREAKER	SQ.D, QOU3100*
2	PCB1,2	PUMP CIRCUIT BREAKER	SQ.D, QOU330*
2	MS1,2	MOTOR STARTER	SQ.D, 8536 (SIZE 1 MIN.)
1	PM	PHASE MONITOR	DIVERSIFIED SLA 230ALA**
1	TVSS	SURGE PROTECTOR	INNOVATIVE TECHNOLOGY PTX080 3D101-240-30-N400480-30
1		PUMP	HYDROMATIC OR ABS, PER SPECS
1		IMPELLER	316 STAINLESS STEEL, PER SPECS
1		WEAR RING	PER SPECS
1		FLOAT LEVEL SWITCHES (1 SET)	ANCHOR SCIENTIFIC INC., PER SPECS

**CITY OF VENICE** 401 W VENICE AVE  
VENICE, FL 34285  
ENGINEERING DEPARTMENT (941) 486-2626



**UTILITIES - LIFT STATION**

**UPS PANEL &  
SPARE PARTS LIST**

DATE  
JAN 2024

SHEET NO.  
**LS-13**

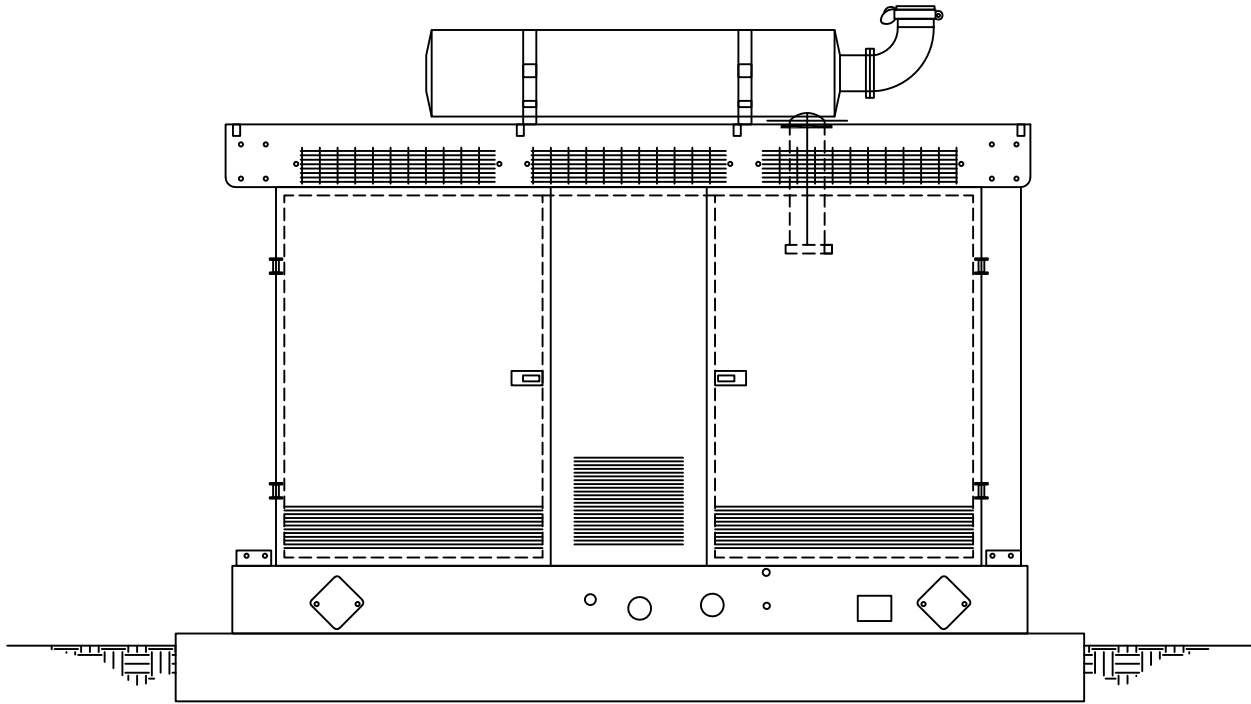

1. PAD SIZE AND GENERATOR SIZE / MODEL TO BE SPECIFIED ON PLANS AND APPROVED BY UTILITIES DIRECTOR.
2. GENERATORS REQUIRED AT ALL NEW LIFT STATIONS UNLESS UTILITIES DIRECTOR APPROVES NOT PLACING.
3. A GENERATOR AND APPURTENANCES SHALL BE PROVIDED AND INSTALLED FOR EXISTING LIFT STATIONS WHEN A NEW LIFT STATION CREATES A RE-PUMP CONDITION VIA GRAVITY OR PRESSURE, UNLESS OTHERWISE APPROVED BY THE UTILITIES DIRECTOR.

## EMERGENCY GENERATOR

N.T.S.

**CITY OF VENICE** 401 W VENICE AVE  
 ENGINEERING DEPARTMENT VENICE, FL 34285  
 (941) 486-2626



**UTILITIES - LIFT STATION**

**EMERGENCY  
 GENERATOR**

DATE  
 JAN 2024

SHEET NO.  
**LS-14**