

City of Venice

DEPARTMENTS OF ENGINEERING & UTILITIES



Venice, Florida
"City on the Gulf"

STANDARD DETAILS, GENERAL NOTES AND TESTING REQUIREMENTS

UPDATED: JANUARY 2018

VENICE CITY COUNCIL

John Holic – Mayor
Robert Daniels – Vice Mayor
Mitzie Fiedler
Fred Fraize
Jeanette Gates
Chuck Newsom

CITY MANAGER

Edward Lavallee

CITY ENGINEER

Kathleen J. Weeden, P.E.

UTILITIES DIRECTOR

Javier A. Vargas

City of Venice

STANDARD DETAILS, GENERAL NOTES AND TESTING REQUIREMENTS

TABLE OF CONTENTS

DETAILED DRAWING INDEX.....	2
1 – General Requirements and City Permits.....	4
2 – Contact Personnel	5
2.1 City of Venice Staff.....	5
2.2 Florida Department of Health.....	5
2.3 Sarasota County Air and Water Quality	6
3 – Construction Plan Submittal Requirements	6
3.1 Title Sheet.....	7
3.2 Existing Conditions Plan	7
3.3 Approved Site Plan.....	7
3.4 Master Grading & Drainage Plan	8
3.5 Master Paving & Striping Plan.....	8
3.6 Master Utility Plan.....	8
3.7 City Standard Details.....	8
3.8 Approved Landscape Plan	8
3.9 General Submittal Requirements.....	8
4 – Testing Requirements	9
4.1 Roadways.....	9
4.2 Gravity Sewer	9
4.3 Storm Sewers.....	11
4.4 Pressure Mains.....	11
4.5 Backflow Assemblies	11
5 – Record Drawing Requirements.....	12
6 – Turnover Package Requirements	13
7 – GIS / CAD Standards.....	14
7.1 GIS / CAD Scope of Work.....	14
7.2 Record Drawings	15
7.3 Master Utility Plan.....	16
7.4 Acceptable Technology and Accuracy Requirements.....	17
8 – General Stormwater Notes.....	18

DETAILED DRAWING INDEX

ENGINEERING

SHEET NUMBER

SIDEWALK RAMPS AND CURBING	ENG-1
PAVEMENT RESTORATION	ENG-2
TYPICAL ROADWAY SECTION	ENG-3
TYPICAL DRIVEWAY & SIDEWALK	ENG-4
ACCESSIBLE & TYPICAL PARKING SPACE	ENG-5
EMERGENCY VEHICLE ACCESS	ENG-6
SILT FENCE & CONSTRUCTION EXIT	ENG-7
BRICK PAVERS & PERVIOUS CONCRETE	ENG-8
STORM CONFLICT MANHOLE & BOLLARD	ENG-9
BICYCLE MARKINGS	ENG-10

UTILITIES - GENERAL

SHEET NUMBER

UTILITY PIPE TRENCH	U-1
AUTOMATIC COMBINATION AIR RELEASE VALVE	U-2
TAPPING SLEEVE & VALVE	U-3
VALVE BOX	U-4
UTILITY CONFLICTS & SEPARATIONS	U-5
PIPE FITTINGS & MATERIAL	U-6
RESTRAINED JOINT TABLE	U-7

UTILITIES - WATER

SHEET NUMBER

GATE VALVE	W-1
FIRE HYDRANT ASSEMBLY	W-2
AUTOMATIC FLUSHING DEVICE	W-3
WATER & REUSE METER & BACKFLOW	W-4
BACKFLOW ASSEMBLY (RESIDENTIAL)	W-5
RESIDENTIAL WATER & FIRE METER	W-6
REUSE METER & TEMPORARY MAIN-LINE JUMPER	W-7
RESIDENTIAL METER & SERVICE CONNECTION	W-8
FIRE SERVICE BACKFLOW ASSEMBLY	W-9
FIRE SERVICE VALVE INDICATOR POST	W-10

UTILITIES - SEWER

SHEET NUMBER

PLUG VALVE & MANHOLE COVERS	S-1
SANITARY SEWER MANHOLE	S-2
PRECAST SHALLOW MANHOLE	S-3
SANITARY SEWER SERVICE & CLEANOUT	S-4
SANITARY SEWER DROP MANHOLE	S-5

UTILITIES – LIFT STATION

SHEET NUMBER

LIFT STATION SITE LAYOUT	LS-1
LIFT STATION	LS-2
ISOLATION MANHOLE & BOOT CONNECTION	LS-3
LIFT STATION SCHEDULE & NOTES	LS-4
TELEMETRY CONTROL PANEL & ANTENNA	LS-5
CONTROL PANEL FRONT	LS-6
CONTROL PANEL BACK	LS-7
ENCLOSURE & DEADFRONT LAYOUT	LS-8
BACKPLATE LAYOUT	LS-9
TERMINAL STRIP DIAGRAM	LS-10
CONTROL SCHEMATIC DIAGRAM	LS-11
CONTROL PANEL BILL OF MATERIALS	LS-12
UPS PANEL & SPARE PARTS LIST	LS-13

Section 1. General Requirements and City Permits

1. These City Standard Details are intended to serve as a current set of guidelines and minimum acceptable standards to City staff. Any deviation from these Details, including, but not limited to, alternative materials, suppliers, or manufacturers may be submitted; but are subject to final approval by the City Engineer.
2. These Details are updated and reissued in January of each calendar year. However, due to unique circumstances, changes or modifications may be required by City staff at any time.
3. These Details are intended to meet all current materials for construction qualifications of FDOT as well as applicable ASTM Standards, latest revisions.
4. All construction within the City of Venice shall meet the applicable testing requirements listed in Section 4.
5. A Maintenance of Traffic (MOT) Plan, if applicable, shall be submitted with the Construction Plans to the City Engineering Department.
6. The City Engineering Department issues the following permits:
 - a) Site Preparation Permit - Before any activity such as removal of vegetation, site grading, delivery of fill, or ground breaking, the property owner or his agent will obtain a Site Preparation Permit from the City. No site activity is to begin until a City-approved BMP Plan is in place. A Site Preparation Permit will be issued by the City upon approval of the BMP Plan. A copy of the Sarasota County Tree Removal Permit will be required prior to issuance of the Site Preparation Permit. Contact Sarasota County Natural Resources to apply for the Tree Permit.
 - b) Construction Permit - The Construction Permit allows for all other site improvements not included within a Site Preparation Permit. Requirements for this permit are discussed in Section 3.
 - c) Right-Of-Way Use Permit - Issued for any construction within the City owned Right-Of-Way.
 - d) License Agreement – Issued for any improvement within the City owned Right-of-Way which does not meet the City Standard Details design requirements (i.e. brick paver driveway or structural improvements).

Applications for the above permits are available at the Engineering Department, Forms section of the City Website www.venicegov.com or at the Building Department counter.

7. A Pre-Construction Meeting shall be held for all Construction Permits prior to start of work. The project Engineer of Record (EOR) or Construction Manager shall coordinate the meeting with the Engineering Department, for the purpose of outlining City Standards, testing and inspection requirements, City Department responsibilities, and other related construction concerns. The EOR or Construction Manager shall

provide copies of all applicable State and Federal permits at this meeting, including SWFWMD ERP, NPDES NOI Letter and SWPPP, FDEP, Health Department and/or FDOT.

8. All Shop Drawings shall be submitted as one complete submittal package only, including a shop drawing schedule which catalogs all the shop drawings for the project. Water, Sewer & Stormwater Shop drawing packages shall include all applicable permits (FDEP & SWFWMD) or a letter from the EOR indicating those permits are not required. Submittals will be rejected prior to review if the permits are not included. Shop Drawings must be approved and stamped by the Engineer of Record (EOR) prior to submission to the City Engineering Department for review. Each sheet of the submittal will be individually stamped and initialed by the EOR. Any construction prior to the review and acceptance process is subject to removal at the Contractor's expense.
9. The City of Venice Utilities Department will operate all water valves.
10. Installation of parts must meet all manufacturer's guidelines and requirements.

Section 2. Contact Personnel

2.1 City of Venice Staff:

<u>Position</u>	<u>Services Provided</u>	<u>Phone Number</u>
City Engineer	Administration and Final Approval	(941) 882-7409
Assistant City Engineer	Coordination/Assistance with Records	(941) 882-7410
Projects Coordinator	Permits/Turnover Packages	(941) 882-7411
Engineering Technicians	Construction Observation & Inspection Requests	(941) 232-2641 (941) 445-7640
Utilities Director	Final Utilities Approval	(941) 486-2788
Utilities Field Operations	Utilities Inspection, Meters, Services, Backflow Devices	(941) 480-3333

2.2 Florida Department of Health:

1001 Sarasota Center Blvd
Sarasota, FL 34232
(941) 861-6133

Construction of any water main or extension of an existing system (Including fire services) is required to submit FDEP Form 62-555.900(7): NOTICE OF INTENT TO USE THE GENERAL PERMIT FOR CONSTRUCTION OF WATER MAIN EXTENSIONS FOR PWSs. Please contact the Department of Health for more information. This form is available at the following web address:

<http://www.dep.state.fl.us/water/drinkingwater/forms.htm>

A CERTIFICATION OF CONSTRUCTION COMPLETION AND REQUEST FOR CLEARANCE TO PLACE PERMITTED PWS COMPONENTS INTO OPERATION (FDEP Form 62-555.900(9)) and reproducible record drawings must be signed, sealed, and submitted by the EOR to FDOH. Please contact the Department of Health for more information.

2.3 Sarasota County Air and Water Quality:

Environmental Protection Division
1001 Sarasota Center Blvd.
Sarasota, FL 34232

Construction of any wastewater facility or extension of an existing system is required to submit FDEP Form 62-604.300(8)(a): NOTIFICATION/APPLICATION FOR CONSTRUCTION A DOMESTIC WASTEWATER COLLECTION/TRANSMISSION SYSTEM. Please contact the above address for more information. This form is available at the following web address:

<http://www.dep.state.fl.us/water/wastewater/forms.htm>

Please submit applications to the Engineering Department. Permit applications will not be signed by the Utilities Director until the plans have been approved by the Utilities and Engineering Departments.

A CERTIFICATION OF CONSTRUCTION COMPLETION, REQUEST FOR APPROVAL TO PLACE A DOMESTIC WASTEWATER TRANSMISSION SYSTEM INTO OPERATION (FDEP Form 62-60Y 300(8)(B)) and reproducible record drawings must be signed, sealed, and submitted by the EOR to FDEP. Please contact the above address for more information. Please submit applications to the Engineering Department. Certificate of Construction Completion will not be signed by the Utilities Director until the record drawings have been approved by the Utilities and Engineering Departments.

Section 3. Construction Plan Submittal Requirements

Submit eight (8) sets of construction plans, signed and sealed by a Florida licensed Professional Engineer to the Engineering Department for review after Planning & Zoning technical review approval (Electronic Submittal will be required once the City institutes E-Plan Review Program). Construction plans will not be accepted for review until permit fee has been paid. Construction plan approval will not be issued until Planning Commission approval is obtained, and all required plan revisions are completed. Construction plans must conform to the Planning Commission's approved Site Plan and SWFWMD Permit documents. A City of Venice Construction Permit and all applicable State and Federal permits are required before beginning any work.

Construction plans shall include, but are not limited to, the following:

3.1 Title Sheet:

- a) Project name, as referenced in Technical Review process or note of discrepancy
- b) Plans shall be titled "Construction Plans"
- c) Location map
- d) Index of sheets
- e) Name of owner and contact information
- f) Name of engineer and contact information
- g) Name of surveyor and contact information
- h) Names of providers of all utilities and services for the property
- i) Designation of public versus private improvements (utilities, roads, etc.)
- j) Date plans issued
- k) Percent and acreage of impervious/pervious area (existing and proposed)
- l) Engineer's quantity estimate of infrastructure improvements
 - Linear feet of reclaimed water main
 - Linear feet of potable water main
 - Linear feet of gravity sewer main
 - Linear feet of force main
 - Number of manholes

Required Notes: (To be shown on Cover Sheet)

1. All work conducted in the City of Venice Right-of-Way (ROW) will require the issuance of a ROW Use Permit.
2. All work conducted in Sarasota County and/or FDOT ROW shall require a copy of the issued permits.
3. Tree Removal Permit must be obtained from Sarasota County Natural Resources Department.
4. Post-Development Runoff does not exceed Pre-Development Runoff volume or rate for a 24-hour, 25-year storm event.
5. All Fire Service Backflow Assemblies shall be installed by a certified contractor with a Class I, II, or V Certificate of Competency issued by the State Fire Marshall as per F.S. 633.521
6. Construction site must be posted with 24-hour contact information
7. All utilities, whether public or private, shall meet City of Venice Standards.
8. Contact Public Works Solid Waste Division (941-486-2422) for approval of dumpster location and layout prior to construction

3.2 Existing Conditions Plan:

- a) Boundary and Topographic survey with all existing improvements and easements.
- b) Flood zone designation and limits of the regulatory flood plain.

3.3 Approved Site Plan:

- a) Site Plan must conform to plan approved by Planning Commission.
- b) Site Plan to show plan view of all proposed improvements.

3.4 Master Grading & Drainage Plan:

- a) Construction Plans must conform to the SWFWMD Stamped, Approved Plans and Permit Conditions.
- b) Individual lot grading plan shall be shown with the proposed finished floor elevation.

3.5 Master Paving & Striping Plan:

3.6 Master Utility Plan:

- a) Profiles shall be shown for all pipelines. Minimum separation and cover shall be maintained and noted at crossing with other utilities in accordance with these Standard Details.
- b) Proposed Swing Table shall be included in Construction Plan submittal.
- c) Proposed site lighting with utility overlay shall be provided to verify that conflicts do not exist (existing and proposed).

3.7 City of Venice Standard Details (latest version):

- a) Designation (See Sheet___) shall be provided on applicable sheet for improvements to be constructed in accordance with the COV Standard Details.
- b) All applicable City Standard Details shall be included in the Construction Plan submittal in their entirety, placed onto the EOR's project title block. Details which do not apply to the project may be excluded from the plan set.
- c) These City Standard Details represent the minimum acceptable improvements for projects built within the City and must be signed & sealed by the EOR certifying the details are appropriate for the specific project.
- d) Site conditions of an individual project could warrant an increased design standard from these details. No alteration or modification of the individual City Details is permitted, unless the design professional is increasing the design standard. Any proposed detail changes shall be provided on a separate sheet of the Construction Plan submittal with the revision clearly identified.
- e) Any additional Details provided by EOR must meet or exceed the minimum design standard in the COV Standard Details.
- f) Digital copies of the latest Standard Details may be obtained from the Engineering Department, Forms section of the City website @ www.venicegov.com.

3.8 Approved Landscape Plan:

- a) The approved TRC Landscape Plan shall be included in the Construction Plan set. Landscape Plan shall indicate ALL plants proposed for installation and include a utility overlay to verify that conflicts do not exist.

3.9 General Submittal Requirements:

- a) North arrows and scales shall be shown on each applicable sheet.
- b) Additional sheets may be necessary to accurately depict the scope of the project or as required by the City Staff for clarity.
- c) Maximum Construction Plan size allowed is 24"X36" Sheets.

- d) All Right-of-Ways, Easements for drainage, utilities, or other public facilities, which will be relinquished to the City, shall be shown on the respective Master Plan Sheets.
- e) As required by the Florida Board of Professional Engineers, each plan sheet must be signed and sealed by the EOR.
- f) If the development will be phased, all phase lines and sub-phases must be clearly shown on a separate **Phasing Sheet**. Any changes of the phase lines shall be submitted as a Construction Plan Modification for City review and approval.

Section 4. Testing Requirements

The Engineer of Record shall provide testing specifications which are consistent with the following:

4.1 Roadways:

All roadways shall be tested in accordance with the City of Venice Standard Details & FDOT Specifications.

4.2 Gravity Sewer:

a) Compaction testing

- Shall be performed on the upstream and downstream side of each manhole/structure.
- Shall be performed at the mid-point of each run of pipe installed.
- Shall be performed at 12" lifts, beginning at the springline of the pipe and alternate sides of the pipeline with each lift.
- Shall be minimum of 98% of maximum compaction under pavement, 95% of maximum compaction under other surfaces as determined by AASHTO Method T-180.

b) Deflection Testing (Mandrel)

- Shall be performed in accordance with ASTM D3034, latest revision.
- Minimum mandrel diameter shall be 95% of the pipeline interior diameter.
- Provide 48 hour advance notification to the City of Venice Engineering Department.

c) Air Test gravity lines and services

- The maximum pressure drop allowable shall be one (1) pound per square inch (PSIG): Refer to Air Test Table below. The minimum initial test pressure shall be three and one half (3 1/2) pounds per square inch (PSIG) except when testing in areas with high water tables. For every foot of groundwater above the springline of the pipe, increase the test pressure by (0.43 PSIG). Maximum test pressure shall be nine (9) PSIG, or not exceeding manufacturer's recommendations. Provide 48-Hour advance notification to the City of Venice Engineering Department.

FROM THE UNI-BELL HANDBOOK OF PVC PIPE
 SPECIFICATION TIME REQUIRED FOR A 1.0 PRESSURE DROP FOR SIZE AND LENGTH OF PIPE INDICATED.
 SEE DETAIL 4, NOTE 2c ON SHEET G-1 FOR TEST PRESSURE CALCULATION.
 THE EOR SHALL PROVIDE TESTING SPECIFICATIONS CONSISTENT WITH THE FOLLOWING TABLE FOR PVC AND DIP:

1 PIPE DIAMETER (INCHES)	2 MINIMUM TIME (MIN:SEC)	3 LENGTH FOR MINIMUM (FEET)	4 TIME FOR LONGER (SECONDS)	SPECIFICATION TIME FOR LENGTH (L) SHOWN (MIN., SEC)								
					100 FT.	150 FT.	200 FT.	250 FT.	300 FT.	350 FT.	400 FT.	450 FT.
4	3.46	597	0.380	L	3.46	3.46	3.46	3.46	3.46	3.46	3.46	3.46
6	5.40	398	0.854	L	5.40	5.40	5.40	5.40	5.40	5.40	5.42	6.24
8	7.34	298	1.520	L	7.34	7.34	7.34	7.34	7.36	8.52	10.08	11.24
10	9.26	239	2.374	L	9.26	9.26	9.26	9.53	11.52	13.51	15.49	17.48
12	11.20	199	3.418	L	11.20	11.20	11.24	14.15	17.05	19.56	22.47	25.38
15	14.10	159	5.342	L	14.10	14.10	17.48	22.15	26.42	31.09	35.36	40.04
18	17.00	133	7.692	L	17.00	19.13	25.38	32.03	38.27	44.52	51.16	57.41
21	19.50	114	10.470	L	19.50	26.10	34.54	43.37	52.21	61.00	69.48	78.31
24	22.40	99	13.674	L	22.47	34.11	45.34	56.58	68.22	79.46	91.10	102.33
27	25.30	88	17.306	L	28.51	43.16	57.41	72.07	86.32	100.57	115.22	129.48
30	28.20	80	21.366	L	35.37	53.25	71.13	89.02	106.50	124.38	142.26	160.15
33	31.10	72	25.852	L	43.05	64.38	86.10	107.43	129.16	150.43	172.21	193.53
36	34.00	66	30.768	L	51.17	76.55	102.34	128.12	153.50	179.29	205.07	230.46
a.) FOR PIPE LENGTHS GREATER THAN FOUR HUNDRED FIFTY (450) FEET BUT LESS THAN LENGTH IN COLUMN 3, USE MINIMUM TIME IN COLUMN 2.				EXAMPLE: DETERMINE TEST TIME FOR 425 FEET OF TWELVE (12) INCH PVC.								
b.) FOR PIPE LENGTHS GREATER THAN FOUR HUNDRED FIFTY FEET AND GREATER THAN LENGTH IN COLUMN 3, SUBTRACT LENGTH OF COLUMN 3 FROM ACTUAL PIPE LENGTH, THEN MULTIPLY DIFFERENCE BY TIME IN COLUMN 4 AND ADD TO TIME IN COLUMN 2.				CONVERT min:sec TO SECONDS (min. X 60) + sec: t400 = 360 s; 450=480s INTERPOLATE t425 = 363s + (408 - 363) X (425 - 400) T425 386s (450 - 400)								
NOTE: INTERPOLATE BETWEEN VALUES ON TABLE AS SHOWN IN EXAMPLE FOR AIR TEST.				CONVERT SECONDS TO min:sec (386 sec/60) = 6.43 min. 6.43 min. = 6 min. + (60 X 0.43) t425 = 6 min. 26 sec. NOTE: FOR LENGTHS GREATER THAN FIVE HUNDRED (500) FEET CONTACT THE EOR.								

d) Television Inspection

- Upon construction completion, any deflection causing a depth of water greater than 1/2" is unacceptable and must be repaired or replaced. The Owner shall provide an .mpg file of the television inspection for all gravity sewer piping being turned over to the City prior to acceptance of improvements.
- At time of one-year warranty inspection, any deflection causing a depth of water greater than 1" is unacceptable and must be repaired or replaced. The Owner shall provide an .mpg file of the television inspection for all gravity sewer piping turned over to the City prior to City release of the maintenance bond.

4.3 Storm Sewers:

- a) Storm Sewers shall be tested as per FDOT Specifications and include compaction testing in conformance with Item 4.2.a above, Gravity Sewer Compaction Testing.
- b) The Owner shall provide a video tape of the camera inspection for all drainage piping being turned over to the City prior to acceptance of the improvements. Video inspection shall be conducted within one year and shall be completed when the ground water is at or above normal elevation.

4.4 Pressure Mains (Potable, Reclaimed, Force Mains):

- a) Compaction testing shall be performed every 250 feet.
- b) Pressure Test (Main)
 - Prior to testing, all air must be expelled from the pressure main.
 - Test pressure shall be: Water (Potable & Reclaimed) Mains: 150 PSI
Force (Wastewater) Mains: 100 PSI
 - Test pressure shall be held for a minimum of 2 hours
 - Allowable leakage shall be calculated with the following:
$$L = S D \sqrt{P / 148,000}$$

L= Allowable leakage, GPH
S= Length of pipe tested, FT
D= Diameter of pipe, IN
P= Average test pressure, PSI
- c) Contact the Building Department for Fire Service testing requirements and scheduling.
- d) Pressure Test (Tapping sleeve & valve) shall be in conformance with these Standards.
- e) Bacteriologic testing of Potable Mains shall be coordinated through COV Utilities Dept. and in conformance with State of Florida Department of Health. Bacterial sample shall be taken by a certified laboratory or FDOH Personnel only.
- f) For all water needed for flushing, pressure testing or bacteriological sampling, please provide 48 hours advance notice to the City of Venice Utilities Department (941) 480-3333. The City will operate all valves.
- g) Disinfecting of water mains must follow ANSI/AWWA 651-99 and must be witnessed by City Utilities. 48-Hr. (480-3333). Disinfection plan to be submitted to COV Utilities Dept. for review & approval prior to scheduling disinfection.
- h) Force Mains shall be a minimum of 4" in diameter.
- i) There shall be no lead products used in any Potable Water infrastructure including pipes, fittings or joints.

4.5 Backflow Assemblies:

- a) Backflow Assemblies shall be tested upon installation In accordance with the City's Cross Connection Control Program Manual. Results shall be submitted to the Utilities Department within 72 hours.

Section 5. Record Drawing Requirements

- 1.) Record Drawings shall be in the same format as the approved Construction Drawings (Plan and Profile). The Record Drawings shall be developed, signed, and sealed by the EOR. In order to verify conformance with the approved Construction Plans this certified information shall be provided to the EOR by a Professional Surveyor & Mapper (PSM) licensed in the State of Florida. Water and Sewer Certifications of Completion will not be signed by Utilities Director until Record Drawings are approved.
- 2.) As a minimum, the Record Drawings shall consist of the following:
 - a) Accurate dimension shall be provided for all improvements to be turned over to the City upon construction completion. Typically, this includes pipes, valves, manholes, lift stations, roadways, signage, sidewalks, swales, stormwater facilities, etc.
 - b) A minimum of two (2) swing ties shall be provided for each valve, fitting, and other underground appurtenances and shown in table format. If distance to swing tie pt. (manhole, curb inlet, etc.) is more than 200', A brass disc (see valve box Detail) may be set in curb with designation "ST#." Proposed Swing Tie Table shall be included with Construction Plans.
 - c) Top of pipe elevations and finish grade elevations shall be provided at a maximum of 100 foot intervals.
 - d) Easements, Right-of-Ways and property lines shall be correctly shown and consistent with any recorded plats. If a Blanket Easement has been granted, place appropriate Note on each pertinent Plan Sheet.
- 3.) Record Drawing Submittal Procedure:
 - a) Submit three (3) copies and CD-ROM with electronic files to the City Engineer's office labeled as Preliminary Record Drawings for review and comment by City staff. Field verification of said improvements and format verification of the electronic files will be conducted at this time. All spare parts shall be delivered to the City of Venice prior to Record Drawing review.
 - b) Upon integration of all City comments, submit three (3) original sets of Final Record Drawings (with EOR signature and seal) to the City Engineer's office.
 - c) Submit, in AUTOCAD and PDF format and/or GIS Data Shape file, all files necessary to print/plot the Record Drawings. This shall be provided on CD-ROM and shall conform with the requirements in Section 7.
 - d) The EOR (Engineer of Record) shall submit SWFWMD Stormwater Record Drawings and copy of the form - STATEMENT OF COMPLETION AND REQUEST TO TRANSFER TO OPERATION ENTITY, to the City Engineer's office.
 - e) A Final Certificate of Occupancy (CO) shall not be granted if the above Record Drawing submittal requirements have not been met.

Section 6. Turnover Package Requirements

Upon construction completion, portions of the project that will be maintained by the City must be 'Turned Over' to the City. City acceptance of improvements, such as water, reclaimed water, sewer, stormwater systems and roadways, require that all improvements be constructed in accordance with the latest version of the City Standard Details, be certified complete by the appropriate regulatory authority and submittal of all required Turnover Package documentation. A CO will not be issued until this process is completed.

The City is required to have the Plat reviewed for conformity with FL Statutes by a Professional Surveyor and Mapper contracted or employed by the City and registered under Chapter 472 F.A.C. Costs shall be borne by the legal entity offering the Plat for recording. A minimum of four (4) weeks is necessary before any Plat can be sent to City Council for approval.

All completed Turnover Package documentation must be submitted to the City Engineering Department a minimum of three (3) weeks prior to the City Council meeting. City Council meetings are normally the 2nd and 4th Tuesday of the month; therefore, the deadline for submittal of complete Turnover Packages is 4 P.M. on the TUESDAY three (3) weeks prior to the City Council meeting. A copy of the City Council calendar is available on-line at www.venicegov.com.

A Complete Turnover Package includes all of the following items if applicable to the project:

- a) Bill of Sale for the lines, and/or systems
- b) Affidavit of No Liens
- c) Certification of Contributions in Aid of Construction
- d) Final Cost Letter & Cost Breakdown worksheet (verification of final costs by EOR)
- e) Legal Description
- f) Copy of Plat (if new Subdivision, or if existing is re-divided)
- g) Contractual Guarantees from Owner
- h) Easements granting right of access to lines and/or systems within private property
- i) A Maintenance Bond in the amount of at least 15% of the cost of construction of the improvements to be turned over, secured by an Irrevocable Letter of Credit or Bond from an approved surety company, or cash, whereby the principal agrees to perform any required maintenance or testing for a period of one year from the date of acceptance by the City.
- j) Declaration of Maintenance Responsibilities
- k) Signed and sealed final record drawings approved by the City of Venice Engineering and Utilities Departments. (Please see above for the record drawing requirements and submittal procedure).
 - Record drawings must be approved by the Engineering and Utilities Departments prior to processing Completion Certifications for Sarasota County Air and Water Quality or DOH. An incomplete Turnover Package will not be placed on the Council Agenda for the next scheduled meeting.

- In order to expedite the record drawing and turnover process, please verify that record drawings are accurate at first submittal. Record drawings must be reviewed by the Engineering and Utilities Departments each time revised drawings are submitted. Turnover Packages will not be considered complete until signed and sealed copies of the record drawings approved by the Engineering and Utilities Departments are submitted.

These requirements are based on Resolution 853-84, approved and adopted by the City Council on November 27, 1984.

A Turnover Package, including instructions and required forms, is available for pick-up, regular mail or via email from the City Engineering Department.

At time of one-year warranty inspection, all systems must be operational. City staff may require property owner to conduct verification testing if necessary to determine condition of improvements. Typically this includes, but is not limited to, the following:

- Valves
- Fire Hydrants
- Backflow Assembly
- Lift Station
- Gravity collection pipes
- Force Mains
- Water Lines
- Manholes
- Roadway condition
- Storm Sewers

Section 7. GIS / CAD Standards

7.1 GIS / CAD SCOPE OF WORK:

- 1.) The CITY OF VENICE (COV) has adopted Geographic Information System (GIS) technologies to store, manage, and maintain geographic/spatially-related data. Likewise, the majority of the civil engineering community has evolved to the point where the predominating design environment is Computer-Aided Design. The purpose of this section is to set a basic CAD/GIS standard to ensure consistent electronic and paper deliverables. These standards and procedures are for integration of digital engineering CAD drawings and attribute data into the database environments, while maintaining the integrity and positional accuracy of the data.
- 2.) It is important that the consultant read over the entire digital standards document to become as familiar with the requirements as possible, and shall be the first source of reference when questions arise.

3.) Upon review of the digital submittals, the COV shall contact the consultant to discuss problems or omissions in the digital data submission to ensure compliance of these standards.

7.2 RECORD DRAWINGS:

1.) Only drawings relevant to the project's phase of submittal shall be included. For example, do not include "Bid Set" or "Proposed" drawings in the submitted "RECORD DRAWING" submittals. Also, do not include drawings or documents that would not normally be included in the set of printed drawings, except for base drawings or drawings to be externally referenced.

2.) Record drawing data to be uploaded Shall include only new construction on an independent layer and care shall be taken to exclude any "existing" facilities from this dataset so as to not duplicate information in GIS. Existing data can be included in the drawing but should reside on separate layers. It is recommended that the prefix "EX" be added to the layers of all existing data, "PROP" for proposed and "AB" for as built.

3.) All text shall appear on separate layers from the layers they annotate. For example, text describing a water main shall be on the WATER_MAIN-TXT layer and not the WATER_MAIN layer.

4.) Sewer Gravity Lines and Force Mains shall be drawn as polylines and broken only at changes in pipe type, valves, tees, crosses, bends, elbows, manholes and reducers.

5.) Water lines shall be drawn as polylines and broken only at changes in pipe type, valves, tees, crosses and reducers.

6.) All line work and objects shall be created using the standard AutoCAD "OSNAP" command ensuring proper joining of features. Objects inserted such as valves, meters, hydrants, etc. shall be snapped to the appropriate endpoint.

7.) All drawings and XREFs need to be geographically registered in the Florida State Plane Coordinate System, units US Survey feet, horizontally corrected to the North American Datum of 1983 using the HARN (High Accuracy Reference Network) correction, vertically corrected to the North American Vertical Datum of 1988.

8.) All External References (x-refs) shall be bound to create a completely independent and standalone drawing.

9.) The following are file format and layer name standards:

a) A folder shall be created with the named project and phase number.

b) A file named MasterUtilityPlan.dwg with site_plan.dwg x-ref bound and only the following layers visible:

- Layer containing Water showing all pertinent features
- Layer containing Reclaimed and all pertinent features

- Layer containing Sanitary Sewer and all pertinent features
 - Layer containing Raw Water and all pertinent features
 - Layer containing Parcel Features and all pertinent features
- c) Include any other files pertinent to the project as independent layers (survey, details, x-refs etc.) either turned off or on separate layers.

7.3 MASTER UTILITY PLAN:

1.) A Master utility plan of the affected construction area shall be submitted in an encompassing file that includes the overall utility system layout and associated parcel features. Feature point, line and polygon information for new or altered structures in the work area and all accompanying geodetic control and survey data shall be included in the master plan.

2.) Master Utility plan digital data shall be provided by the engineer, and consist of the affected construction area showing the new construction, existing infrastructure, deletion or alteration of infrastructure and its related properties. This drawing is subject to the requirements set forth in this document and will be used by the COV to input data into the GIS system. There are some basic “rules” that apply to the process of creating the proposed or altered features within the overall plan drawing. The following rules shall be adhered to in order for the data to be efficiently downloaded into the GIS

- a) The drawing shall be submitted in specified state plane coordinates with at least two points referenced to Sarasota County’s geodetic control network with a horizontal accuracy of plus/minus three centimeters. For any vertical measurements, at least three points shall be referenced to Sarasota County’s geodetic control network with an accuracy of plus/minus five centimeters. Features in drawing files that are stored in drawing units will be translated to real world locations. The geodetic control chosen shall correspond to existing monuments in Sarasota County’s control network. The new structures and features shall be geographically registered to the geodetic control. State Plane coordinates exist for most quarter section corners in Sarasota County. If the geodetic control point is located within the project limits, it shall be symbolically indicated and annotated in the design file. If the nearest geodetic control is located well outside of the project area then it shall be tied to one of the other geodetic control points used, and a reference tie annotated and indicated in the design file. The two geodetic control points described above are the least survey grade geo-referencing information a developer can use to create the plan view drawing. All drawings need to be geographically registered in the Florida State Plane Coordinate System, units US Survey feet, horizontally corrected to the North American Datum of 1983 using the HARN (High Accuracy Reference Network) correction, vertically corrected to the North American Vertical Datum of 1988.
- b) The spatial accuracy of the feature data contained in the Master plans shall be equal to or better than the graphical data contained in the plan/profile sheets.
- c) Pressure piping is to be entered as a single line between tees, crosses, wyes, and reducers. Pipe sections should be continuous through structures such as

valves and other fittings. Pipes should be broken and joined by a suitable fitting when a line changes its diameter or material properties. For wastewater force mains, the line feature(s) shall be input using the same direction from point to point as the proposed or existing flow. Therefore, the starting point of force main line segments within these layers shall be the upstream point and the downstream point shall be the endpoint of that segment. This procedure is required to indicate the continuity of flow and connectivity within the wastewater layers.

- d) Gravity lines shall be entered as a single line, digitized in the direction of the design flow, and broken at manholes.
- e) Text identifying piping shall be aligned with the piping. Point and linear feature attribute text shall be visible on the drawing in a standard font and the lower left-hand corner of the text shall be just clear of the linear or point feature to which it corresponds, unless legibility requires that the label be moved and accompanied by a leader arrow. The labels shall be placed onto a separate layer not to be placed in the feature layer. For reading from the bottom or right side of the plan sheet, the rotation angle shall be between -90 degrees and 90 degrees.
- f) Features shall be placed on their appropriate layers and assigned colors by layer for consistency. Features shown in the AutoCAD files shall be in model space and be contained in the AutoCAD files as opposed to being linked to externally referenced files. CADD systems which use a numbering system for layers instead of names shall also include a conversion chart explaining which layer number corresponds with which layer name.

The features included in the Master Utility plans(s) shall follow the standards in Section 7.2 RECORD DRAWINGS.

7.4 ACCEPTABLE TECHNOLOGY AND ACCURACY REQUIREMENTS:

1.) GPS units used to collect data must be accurate to sub-meter when differentially corrected and shall depict actual horizontal and vertical locations of utility assets such as: manholes, system valves, hydrants, blow-off valves, air release valves, master meters, and the pump station wet well. Also, the locations at the intersection of water, wastewater and reclaimed water pressure piping, as well as at 100 feet intervals along the pipeline. A surveyor shall certify the state plane coordinates, provide the coordinates on the AS-BUILT DRAWINGS, and provide the coordinate attribute table in an electronic database submittal. GPS units that do not meet this standard will not be acceptable (Note: Recreational GPS receivers do not comply with these standards).

Section 8. Stormwater General Notes

- 1) All stormwater structures shall be bedded on 6" Min. compacted gravel or crushed stone.
- 2) Stormwater pipes installed below the water table, within wet conditions will require 6" Min. compacted gravel or crushed stone bedding.
- 3) All stormwater pipes and structures within public trafficable areas shall be reinforced concrete unless otherwise approved by the City Engineer.
- 4) Stormwater pipes within private property may be smooth walled HDPE or A-2000 PVC with watertight connections and sufficient cover as calculated by the EOR. Roof drainage pipe may be C900 DR-25 PVC white color or blue color with white tape.
- 5) No lifting holes or other similar penetrations of stormwater piping permitted. All piping joints shall be wrapped with a Mirafi Filter Fabric or equal.
- 6) All pipe joints will be gasketed according to the manufacturer, FDOT and ASTM Standards to provide a leak proof connection
- 7) All pre-cast structures shall meet FDOT and ASTM C-478 Standards.
- 8) Inlet gratings in areas accessible to bicycle or to pedestrian use must be reticulate or of similar manufacture.
- 9) Inlet gratings in corrosive areas shall be galvanized.
- 10) Stormwater inlets should be designed to reject debris, trash, and other pollutants from entering into public stormwater conveyances.
- 11) Outfalls into the surface waters should be designed with devices to reduce the discharge of foreign materials.

ENGINEERING DETAILS

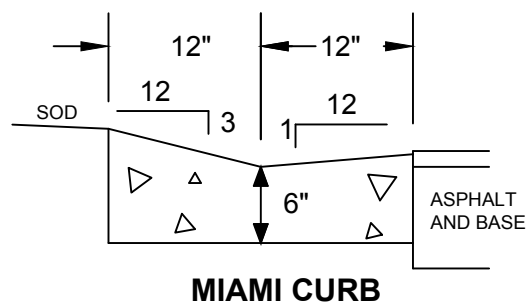
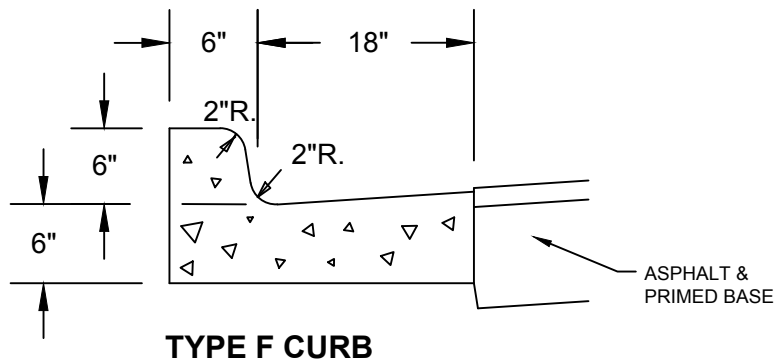

1.) ALL STREETS SHALL HAVE A TWO-FOOT WIDE CONCRETE (3000 PSI AT 28 DAYS WITH FIBER REINFORCEMENT) CURB AND GUTTER, AND MEET OR EXCEED FDOT SPECIFICATIONS UNLESS OTHERWISE APPROVED BY THE CITY ENGINEER.

CURB DETAIL

N.T.S.

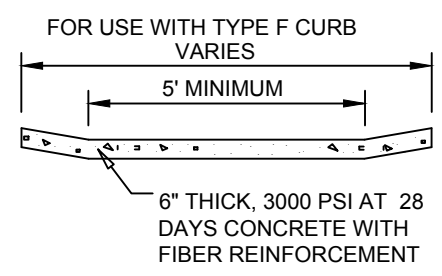
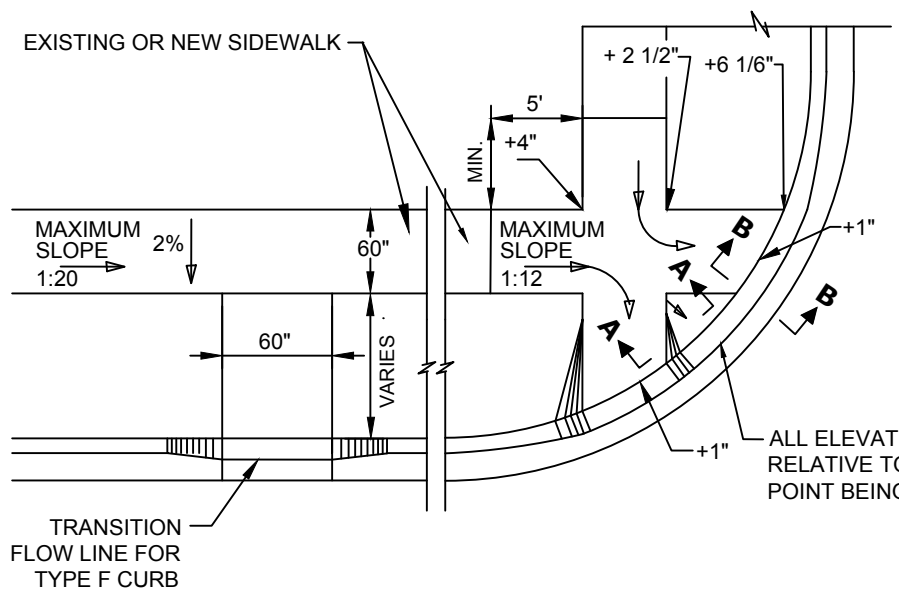

(SECTION A-A)
N.T.S.

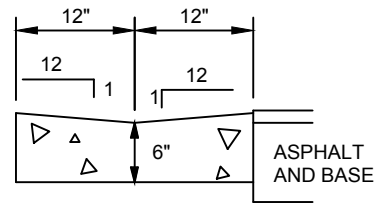

(SECTION B-B)
N.T.S.

- 1.) ALL CONCRETE RAMPS SHALL BE 4" THICK, INCREASING TO 6" THICK WITHIN 48" OF THE CURB
- 2.) ALL CONNECTIONS TO AN EXISTING SIDEWALK SHALL BE AT AN EXPANSION OR CONTRACTION JOINT
- 3.) THE MAXIMUM RAMP SLOPE SHALL BE 1:12, FOR A VERTICAL DISTANCE OF NOT MORE THAN 6 INCHES.
- 4.) THE MAXIMUM RUNNING SIDEWALK SLOPE SHALL BE 1:20, AND MAXIMUM CROSS SLOPE SHALL BE 2%.
- 5.) ALL SIDEWALK RAMPS AND STREET CONNECTIONS WITHIN THE PUBLIC ROW SHALL HAVE A TACTILE SURFACE.
- 6.) TACTILE SURFACES SHALL MEET THE MOST CURRENT AMERICANS WITH DISABILITIES ACT STANDARDS, BE FDOT COMPLIANT AND SHALL BE BRICK RED IN COLOR.
- 7.) ALL MATERIALS & METHODS OF CONSTRUCTION SHALL BE IN ACCORDANCE WITH LATEST EDITION OF THE FDOT, "STANDARDS FOR ROAD & BRIDGE CONSTRUCTION". IN ADDITION, CONCRETE SHALL BE 3000 PSI AT 28 DAYS WITH A MAXIMUM 4" SLUMP AND FIBER REINFORCEMENT.

SIDEWALK RAMP DETAIL

N.T.S.



CITY OF VENICE
ENGINEERING DEPARTMENT

401 WEST VENICE AVE.
VENICE FL 34285
(941) 486-2626
FAX (941) 480-3031

ENGINEERING

**SIDEWALK RAMPS
& CURBING**

DATE
JAN. 2018

SHEET NO.
ENG-1

PLAN VIEW

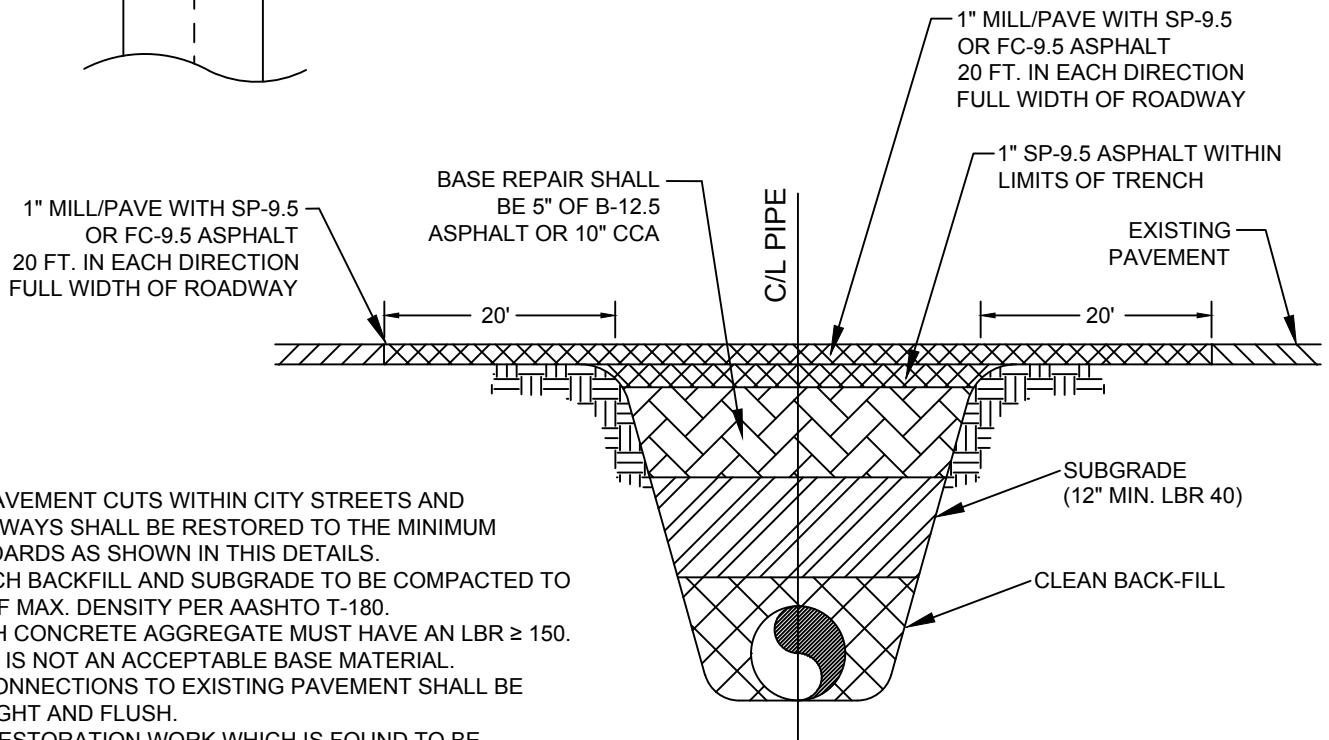
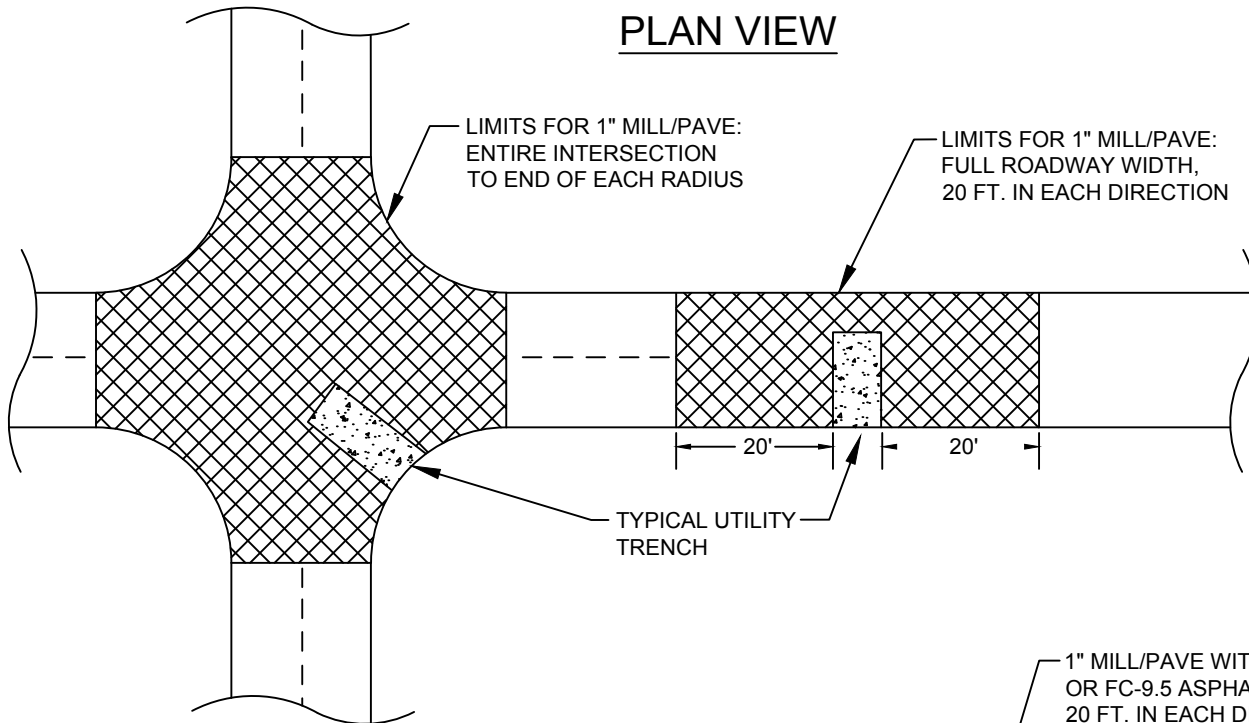

- 1.) ALL PAVEMENT CUTS WITHIN CITY STREETS AND ALLEYWAYS SHALL BE RESTORED TO THE MINIMUM STANDARDS AS SHOWN IN THIS DETAILS.
- 2.) TRENCH BACKFILL AND SUBGRADE TO BE COMPACTED TO 98% OF MAX. DENSITY PER AASHTO T-180. CRUSH CONCRETE AGGREGATE MUST HAVE AN LBR \geq 150. SHELL IS NOT AN ACCEPTABLE BASE MATERIAL.
- 3.) ALL CONNECTIONS TO EXISTING PAVEMENT SHALL BE STRAIGHT AND FLUSH.
- 4.) ANY RESTORATION WORK WHICH IS FOUND TO BE UNSATISFACTORY IN CONDITION SHALL BE REMOVED AND REPLACED AT THE CONTRACTOR/APPLICANT'S EXPENSE.

TRENCH VIEW

PAVEMENT RESTORATION DETAIL

N.T.S.



CITY OF VENICE
ENGINEERING DEPARTMENT

401 WEST VENICE AVE.
VENICE FL 34285
(941) 486-2626
FAX (941) 480-3031

ENGINEERING
PAVEMENT
RESTORATION

DATE
JAN. 2018

SHEET NO.
ENG-2

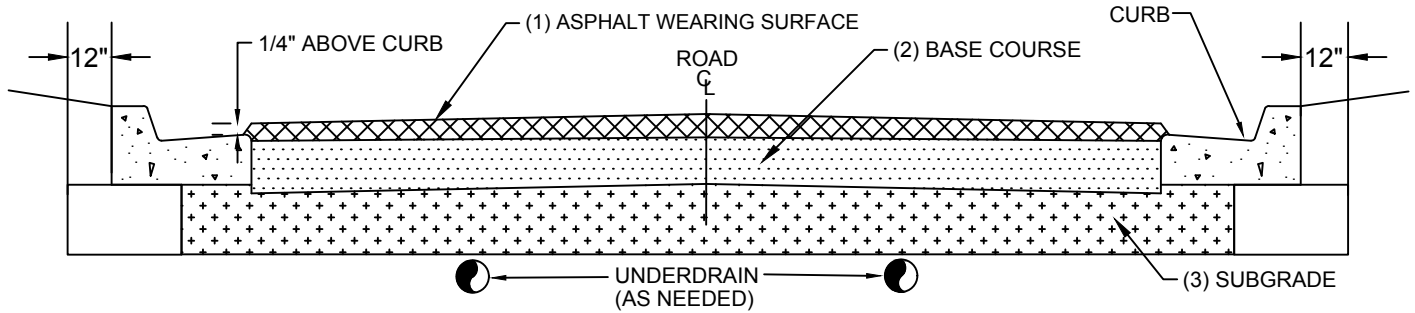

ROADWAY SECTION DESIGN (MINIMUM THICKNESS)

STREET CLASSIFICATION	(1) ASPHALT SURFACE:	(2) BASE:			(3) SUB-GRADE: TYPE B STAB.
		B-12.5	CTB	CCA	
RESIDENTIAL STREET (PRIVATE) & LIGHT DUTY PARKING	2" TYPE SP-9.5 (INSTALLED AS TWO 1" LIFTS)	4"	8"	8"	8" MIN 40 LBR
RESIDENTIAL STREET (PUBLIC)	2" TYPE SP-9.5 (INSTALLED AS TWO 1" LIFTS)	5"	10"	10"	12" MIN 40 LBR
INDUSTRIAL STREET (PUBLIC/PRIVATE)	2" TYPE SP-12.5 & 1" TYPE FC-9.5	5"	10"	10"	12" MIN 40 LBR
COLLECTOR / ARTERIAL STREET	3" TYPE SP-12.5 & 1" TYPE FC-9.5	5"	10"	10"	12" MIN 40 LBR

- 1.) ALL STREETS WITHIN THE CITY LIMITS SHALL MEET THE MINIMUM DESIGN STANDARDS AS ESTABLISHED IN THIS DETAIL.
- 2.) ALL INSTALLATION METHODS AND MATERIALS SHALL CONFORM WITH THE LATEST EDITION OF THE FDOT STANDARD SPECIFICATIONS FOR ROAD AND BRIDGE CONSTRUCTION.
- 3.) CRUSHED CONCRETE AGGREGATE (CCA) MUST HAVE AN LBR ≥ 150 . SHELL IS NOT AN ACCEPTABLE BASE MATERIAL.
- 4.) CEMENT TREATED BASE:
 - a.) THE MATERIAL TO BE USED AS THE FILLER AGGREGATE IN CTB MUST BE LBR TESTED PRIOR TO DESIGN FORMULATION (ADDING CEMENT). THIS MATERIAL MUST ACHIEVE AN LBR VALUE OF ≥ 100 .
 - b.) CTB DESIGN CRITERION SHOULD TARGET RANGE FROM 175 TO 275 PSI ON 7 DAY BREAK. TESTING MUST BE PROVIDED TO VERIFY THE COMPRESSIVE STRENGTH OF THE MIX.
- 5.) ALL GRANULAR COURSES OF ROAD CONSTRUCTION MUST BE COMPACTED TO 98% OF ITS OPTIMUM DENSITY AS PER T-180 (AASHTO). CTB SHALL BE COMPACTED TO 98% OF ITS LAB FORMULATION DENSITY (AASHTO T-99).
- 6.) ALL MINERAL MATERIALS USED IN CONSTRUCTION OF ROADWAYS MUST MEET THE FOLLOWING CRITERIA:
 - a.) FINES (PASSING # 200 SIEVE) MUST BE LIMITED TO $\leq 12\%$, ORGANICS LIMITED TO $\leq 5\%$, NO DELETERIOUS MATERIALS.
- 7.) SIGNAGE AND PAVEMENT MARKINGS SHALL BE IN ACCORDANCE WITH LATEST EDITION OF THE FDOT ROADWAY AND TRAFFIC DESIGN STANDARDS AND THE MANUAL ON UNIFORM TRAFFIC CONTROL DEVICES (MUTCD MANUAL).
- 8.) ALL CITY STREET SIGNS WILL BE BLUE BACKGROUND WITH 6" WHITE LETTERS AND CONSTRUCTED WITH HIGH INTENSITY REFLECTORIZED MATERIAL. ALL STREET SIGNS SHALL BE 9 INCHES WIDE AND APPROVED BY THE DIRECTOR OF PUBLIC WORKS PRIOR TO INSTALLATION.
- 9.) ALL CURB PADS SHALL MEET THE SAME STRUCTURAL AND COMPACTION STANDARDS AS ROAD SUB GRADE. THESE PADS WILL EXTEND TO AT LEAST 12" BEYOND THE CURB.
- 10.) UNDERDRAINS OR SIDEDRAINS MAY BE INCLUDED WHEN THE GROUND WATER LEVELS MAY AFFECT THE STRUCTURAL INTEGRITY OF THE ROAD. THIS DESIGN SHALL BE THE RESPONSIBILITY OF ENGINEER OF RECORD.
- 11.) ANY PROPOSED TRAFFIC CALMING DEVICES MUST BE APPROVED BY THE CITY ENGINEER & FIRE CHIEF.
- 12.) ASPHALT COURSES AND CONCRETE SHALL NOT BE PLACED WHILE RAIN IS FALLING, OR WHEN THERE IS STANDING WATER ON THE SURFACE TO BE COVERED.
- 13.) TACK COAT SHALL BE APPLIED BETWEEN ALL ASPHALT LAYERS.

TYPICAL ROADWAY SECTION

N.T.S.



CITY OF VENICE
ENGINEERING DEPARTMENT

401 WEST VENICE AVE.
VENICE FL 34285
(941) 486-2626
FAX (941) 480-3031

ENGINEERING

**TYPICAL ROADWAY
SECTION**

DATE
JAN. 2018

SHEET NO.
ENG-3

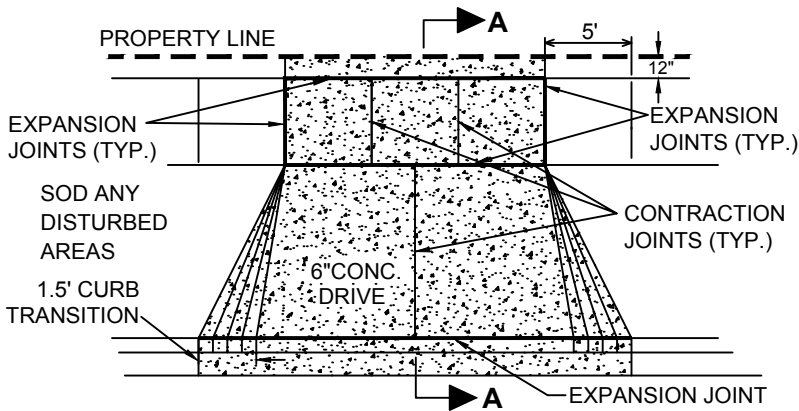

RESIDENTIAL DRIVEWAY

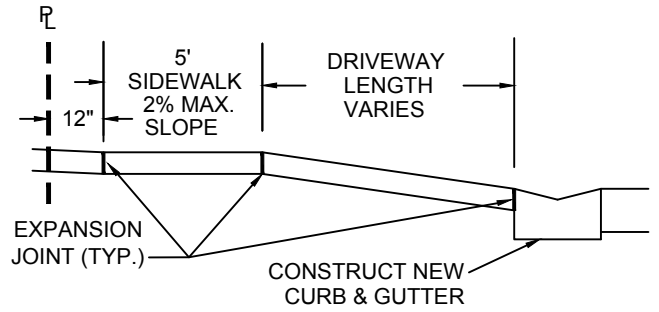

SECTION A-A

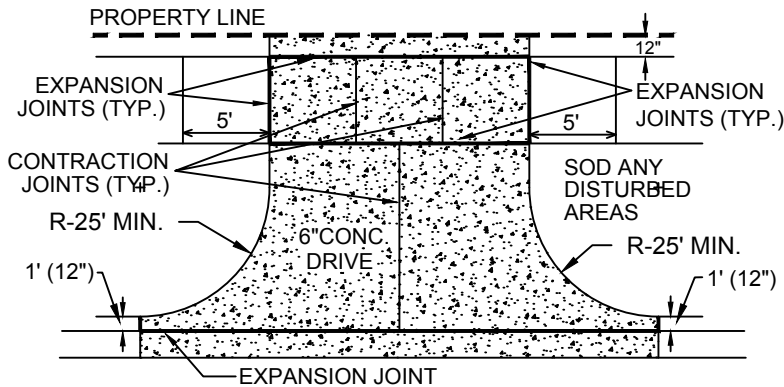

COMMERCIAL/ INDUSTRIAL/ MULTI-FAMILY

- 1.) SIDEWALKS AND DRIVEWAYS SHALL BE CONSTRUCTED OF 3000 PSI AT 28 DAYS CONCRETE (MAXIMUM 4" SLUMP) WITH FIBER REINFORCEMENT.
- 2.) ALL SIDEWALKS SHALL BE 5' WIDE AND CONSTRUCTED WITH A MAX. CROSS SLOPE OF 2% AND MAX. RUNNING SLOPE OF 5%.
- 3.) CONTRACTION SAW-CUTS SHALL BE CONSTRUCTED EVERY 5' LENGTH OF SIDEWALK. EXPANSION JOINTS SHALL BE CONSTRUCTED AT 50' INTERVALS.
- 4.) 1/2-INCH THICK ASPHALTIC FELT OR "PRESSURE TREATED WOOD" SHALL BE PLACED AT EACH EXPANSION JOINT.
- 5.) EXISTING CURB AND GUTTER SHALL BE REMOVED ONLY AT EXISTING JOINTS.
- 6.) DRIVEWAY WIDTH AND LOCATION SHALL COMPLY WITH ZONING CODES, SECTIONS 122-446, 62-64, 62-65.
- 7.) DRIVEWAY SLOPES SHALL BE IN ACCORDANCE WITH THE LATEST EDITION OF THE FDOT, "ROADWAY AND TRAFFIC DESIGN STANDARDS", INDEX 515.

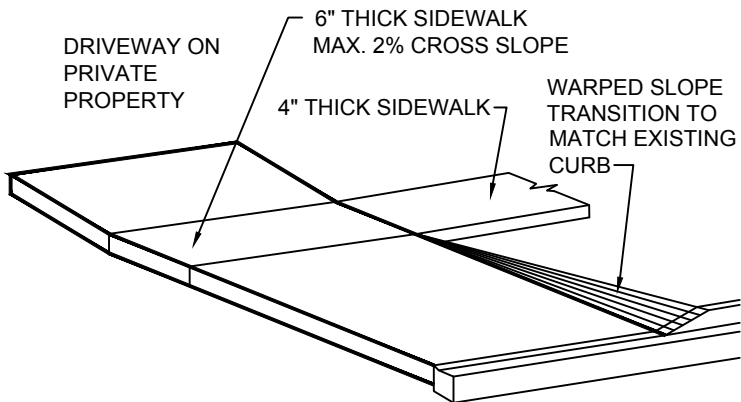

6" CONCRETE RESIDENTIAL DRIVEWAY

DRIVEWAY & SIDEWALK DETAIL

N.T.S.



CITY OF VENICE
ENGINEERING DEPARTMENT

401 WEST VENICE AVE.
VENICE FL 34285
(941) 486-2626
FAX (941) 480-3031

ENGINEERING

**TYPICAL DRIVEWAY
& SIDEWALK**

DATE
JAN. 2018

SHEET NO.
ENG-4

SLOPE UP
1:16 RECOMMENDED
1:12 MAXIMUM

SLOPE UP
1:16 RECOMMENDED
1:12 MAXIMUM

ACCESSIBLE PARKING SIGN MIN. 60"
TO BOTTOM OF PRIMARY SIGN (FAC 502.6)
"PARKING BY DISABLED PERMIT ONLY
\$250 PENALTY" (TYP.)

SIDEWALK

RAMP LANDING
(FAC 405.7)

SIDEWALK

PRECAST
CONCRETE
WHEEL STOP
(TYP. 6"x6"x6')

4" BLUE
STRIPING
(TYP.)

WHITE STRIPING

24" TYP

4" WHITE
STRIPING
(TYP.)

PAVEMENT LOGO
5 FT. IN HEIGHT
AND WHITE IN
COLOR (TYP.)

18' (WITH WHEEL STOP)

10'-0" (MIN.)

12'-0" (MIN.)

5'-0" MIN.

12'-0" (MIN.)

10'-0" (MIN.)

4.6.3 AND/OR
[316.1955(4xa)]

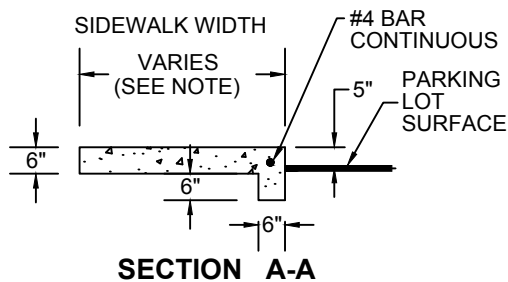

- 1.) IF AN ADJACENT SIDEWALK IS A MINIMUM OF SEVEN (7) FEET IN WIDTH AND PROVIDES A 5" INCH CURB, THE SIDEWALK MAY SERVE AS THE WHEEL STOP AND THE STANDARD PARKING SPACE MAY BE 16' DEEP.
- 2.) IF AN ADJACENT LANDSCAPE AREA IS A MINIMUM OF 3.5' PER ABUTTING PARKING SPACE AND PROTECTED BY CONCRETE CURBING OR WHEEL STOP, 2 FEET OF THE REQUIRED DEPTH MAY ENCROACH INTO THE LANDSCAPE AREA. IF THE REQUIRED DEPTH ENCROACHES INTO THE LANDSCAPE AREA, THE WHEEL STOP MUST BE PLACED AT THE EDGE OF PAVEMENT.
- 3.) ACCESSIBLE PARKING SPACES AND ACCESS AISLES SHALL BE CONSTRUCTED WITH SURFACE SLOPES NOT TO EXCEED 1:50 (2%) IN ALL DIRECTIONS AND THE GROUND SURFACE SHALL BE STABLE, FIRM AND SLIP RESISTANT.
- 4.) NO COLORS OTHER THAN WHITE AND BLUE SHALL BE USED FOR PARKING SPACE PAVEMENT MARKINGS.
- 5.) ALL DIMENSIONS SHOWN ARE TO THE CENTERLINE OF PAVEMENT MARKINGS.

ACCESSIBLE & TYPICAL PARKING SPACE DETAIL

N.T.S.



CITY OF VENICE
ENGINEERING DEPARTMENT

401 WEST VENICE AVE.
VENICE FL 34285
(941) 486-2626
FAX (941) 480-3031

ENGINEERING

**ACCESSIBLE &
TYPICAL PARKING**

DATE
JAN. 2018

SHEET NO.
ENG-5

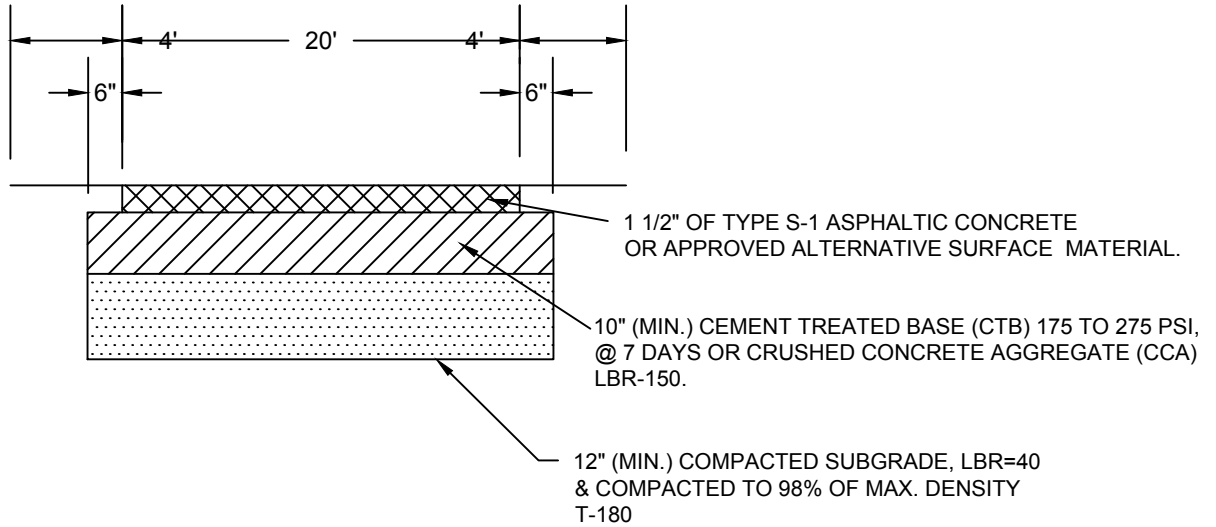

- 1.) ACCESS ROADS SHALL HAVE AN UNOBSTRUCTED WIDTH OF NOT LESS THAN 20' AND AN UNOBSTRUCTED VERTICAL CLEARANCE OF NOT LESS THAN 13'6"
- 2.) ACCESS ROADS SHALL BE DESIGNED AND MAINTAINED TO SUPPORT THE IMPOSED LOADS OF FIRE APPARATUS AND SHALL BE PROVIDED WITH A SURFACE SUITABLE FOR ALL WEATHER DRIVING CAPABILITIES.
- 3.) REQUIREMENTS MAY BE SUBJECT TO CHANGE AS PER UNIFORM FIRE CODE, FLORIDA LATEST EDITION.
- 4.) FIRE LANE SIGNS THAT COMPLY WITH THE REQUIREMENTS OF THE FLORIDA FIRE PREVENTION CODE MUST BE INSTALLED.
 - EMERGENCY ACCESS SHALL BE MARKED WITH FREESTANDING SIGNS WITH THE WORDING:

**NO PARKING
FIRE LANE
TOW AWAY ZONE
F.S.316-1945**

- SUCH SIGNS SHALL BE 12 INCHES BY 18 INCHES WITH A WHITE BACKGROUND AND RED LETTERS AND SHALL BE A MAXIMUM OF 7 FEET IN HEIGHT FROM THE ROADWAY TO THE BOTTOM PART OF THE SIGN.
 - THE SIGNS SHALL BE WITHIN SIGHT OF THE TRAFFIC FLOW AND BE A MAXIMUM OF 60 FEET APART.
- 5.) IT IS IMPERATIVE THAT THIS EMERGENCY ACCESS REMAINS OPEN AT ALL TIMES. IT IS THEREFORE INCUMBENT UPON YOUR STAFF TO NOTIFY THE VENICE POLICE DEPARTMENT ANYTIME A VEHICLE IS BLOCKING THIS REQUIRED EMERGENCY ACCESS.

EMERGENCY VEHICLE ACCESS DETAIL

N.T.S.



CITY OF VENICE
ENGINEERING DEPARTMENT

401 WEST VENICE AVE.
VENICE FL 34285
(941) 486-2626
FAX (941) 480-3031

ENGINEERING

**EMERGENCY
VEHICLE ACCESS**

DATE
JAN. 2018

SHEET NO.
ENG-6

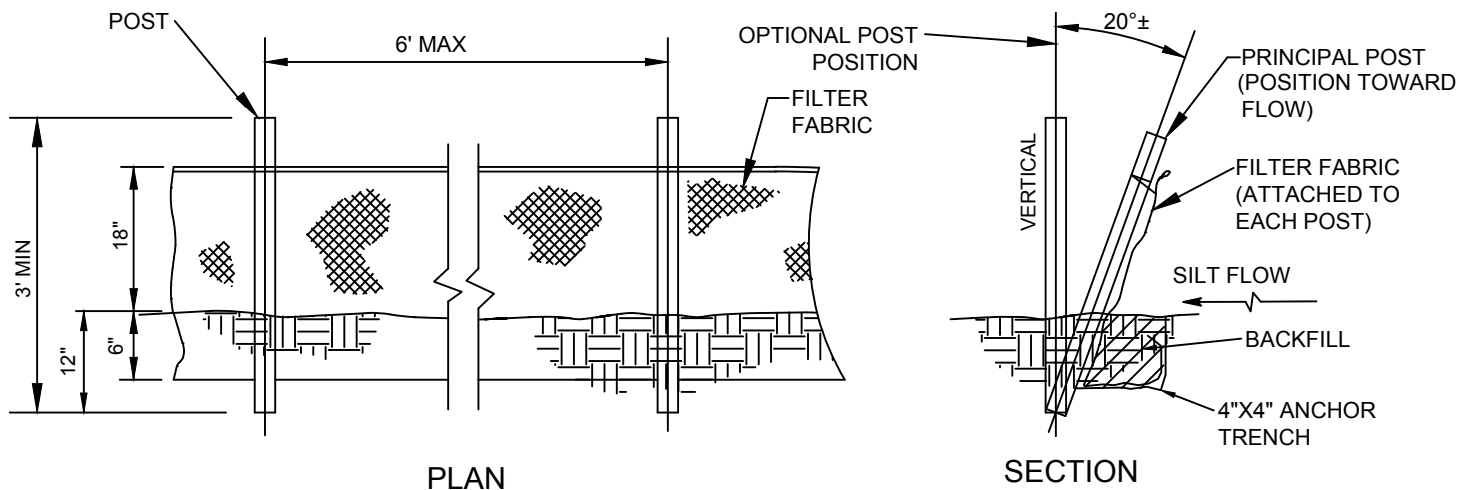

- 1.) POSTS SHALL BE WOOD (2"X4" OR 2 1/2" DIA.) OR STEEL (MIN. 1.33 LBS/FT.).
- 2.) SILT FENCE SHALL BE PLACED PRIOR TO ANY EARTHMOVING, EXCAVATION OR VEGETATION REMOVAL.
- 3.) CONTRACTOR IS RESPONSIBLE FOR MONITORING & MAINTAINING THE SILT FENCE IN GOOD CONDITION THROUGHOUT THE LIFE OF THE PROJECT.
- 4.) THE CITY ENGINEER OR HIS DESIGNEE MAY ISSUE A STOP WORK ORDER IN THE EVENT THAT SILT FENCE IS NOT BEING MAINTAINED OR IF SEDIMENT IS MIGRATING OFF-SITE.

SILT FENCE DETAIL

N.T.S.

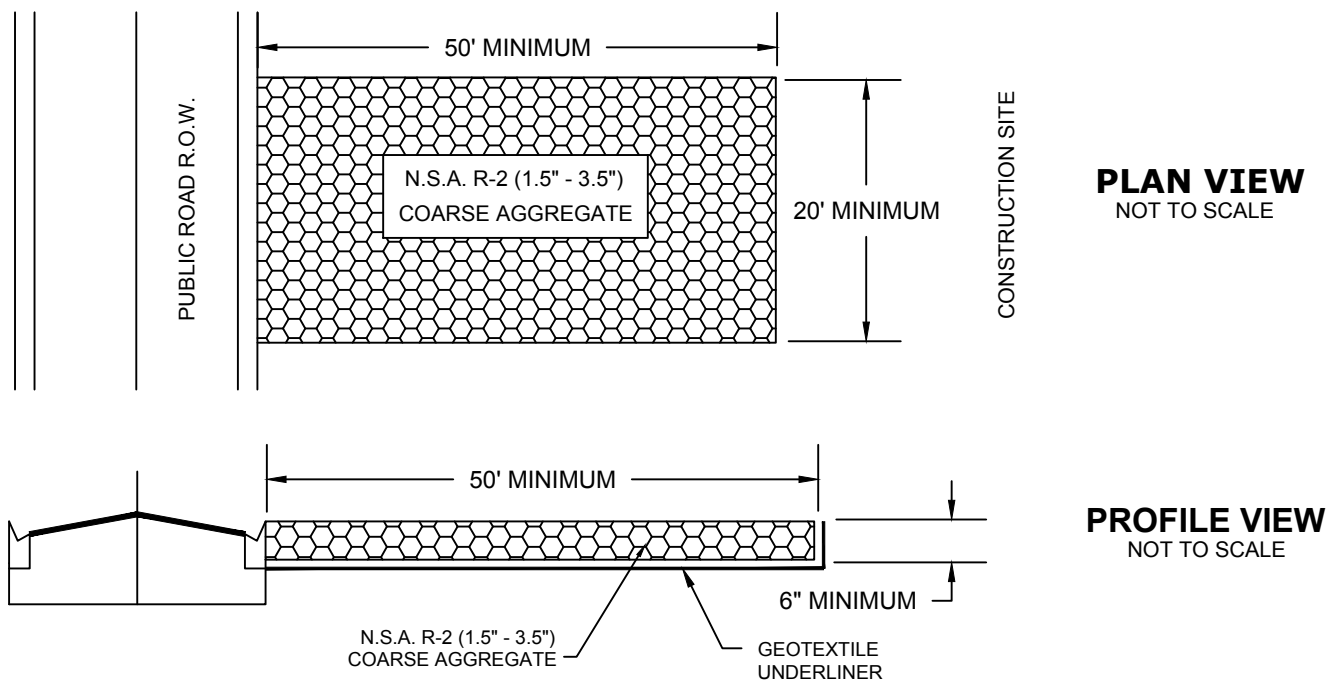

CRUSHED STONE CONSTRUCTION EXIT DETAIL

N.T.S.



CITY OF VENICE
ENGINEERING DEPARTMENT

401 WEST VENICE AVE.
VENICE FL 34285
(941) 486-2626
FAX (941) 480-3031

ENGINEERING

**SILT FENCE &
CONSTRUCTION EXIT**

DATE
JAN. 2018

SHEET NO.
ENG-7

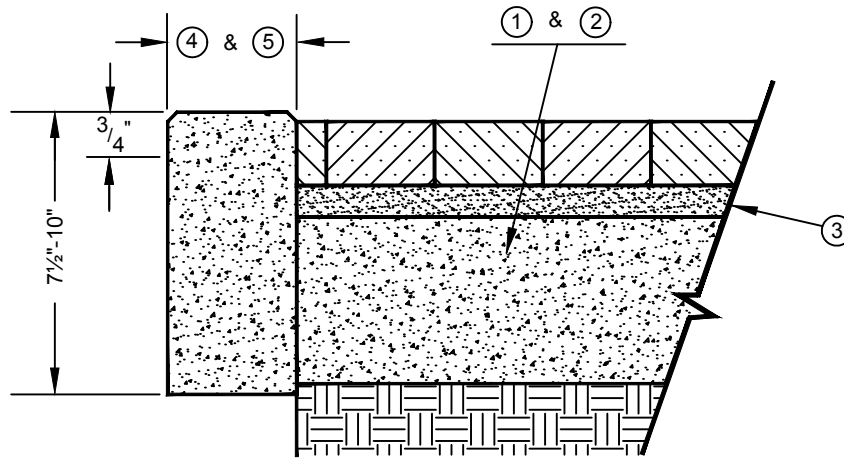

- 1.) 4" POURED CONCRETE 3,000 P.S.I. @ 28 DAYS OR COMPACTED CCA BASE FOR SIDEWALK.
- 2.) 6" POURED CONCRETE 3,000 P.S.I. @ 28 DAYS OR COMPACTED CCA BASE FOR DRIVEWAY.
- 3.) 1" MIN. TO 1 1/2" MAX. SAND BEDDING.
- 4.) 6" POURED CONCRETE BOND BAND SHALL BE INSTALLED WHERE CURB IS NOT PRESENT WITH 3/4" REVEAL AT EDGE OF TRAVEL WAY.
- 5.) 6" POURED CONCRETE BOND BAND SHALL BE INSTALLED ON ALL OUTSIDE EDGES WHERE NO EXISTING OR NEW SOLID STRUCTURE IS PRESENT TO HOLD PAVERS IN PLACE.
- 6.) ALL PAVERS WITHIN TRAFFIC AREAS MUST BE TRAFFIC BEARING.
- 7.) A RIGHT OF WAY USE PERMIT AND AN APPROVED LICENSE AGREEMENT MUST BE OBTAINED IF PAVERS ARE TO BE INSTALLED IN CITY RIGHT OF WAY.
- 8.) PAVER DRIVEWAYS SHALL PROVIDE A FLAT 5 FT. WIDE SECTION, BEGINNING AT 1 FT. INSIDE THE PUBLIC ROW LINE FOR USE AS A FUTURE SIDEWALK CONNECTION.

BRICK PAVER INSTALLATION DETAIL

N.T.S.

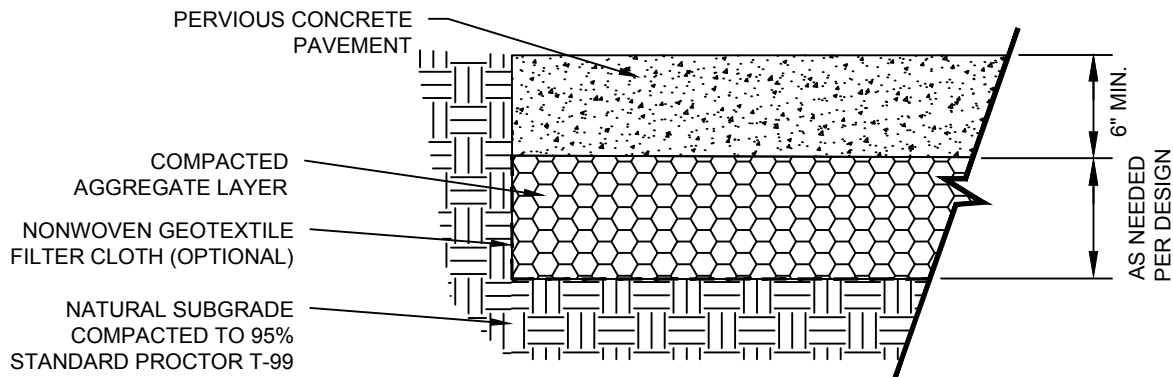

- 1.) FOR USE IN PARKING AREAS AND LOW VOLUME ACCESSWAYS ONLY.
- 2.) ENGINEER OF RECORD SHALL SUBMIT PERVIOUS PAVEMENT DESIGN AND SPECIFICATIONS BASED ON THE SITE SPECIFIC SOIL CONDITIONS, STORMWATER STORAGE REQUIREMENTS AND THE ANTICIPATED TRAFFIC LOADINGS.
- 3.) PERVIOUS CONTRACTORS SHALL BE NRMCA CERTIFIED CRAFTSMEN.
- 4.) PERVIOUS PRODUCER/SUPPLIERS AND TESTING FIRMS SHALL USE NRMCA CERTIFIED TECHNICIANS.
- 5.) POROUS ASPHALT MAY BE USED AS AN ALTERNATIVE MATERIAL AS DESIGNED BY THE EOR.

PERVIOUS CONCRETE PAVEMENT DETAIL

N.T.S.



CITY OF VENICE
ENGINEERING DEPARTMENT

401 WEST VENICE AVE.
VENICE FL 34285
(941) 486-2626
FAX (941) 480-3031

ENGINEERING

**BRICK PAVERS &
PERVIOUS CONCRETE**

DATE
JAN. 2018

SHEET NO.
ENG-8

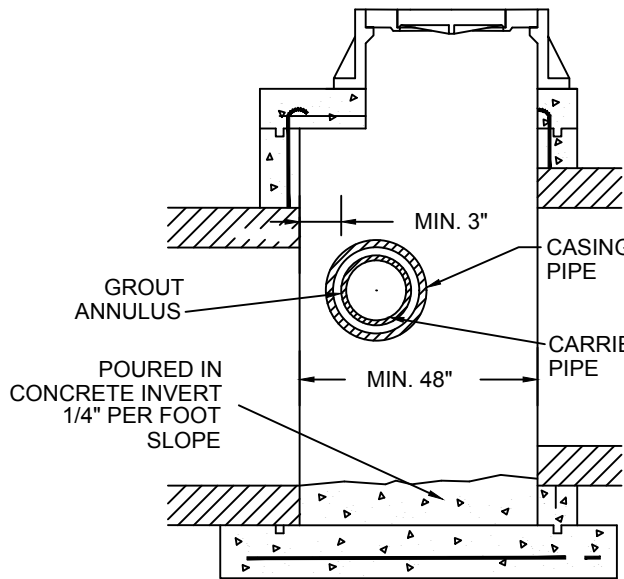

SECTION VIEW

- 1.) TYPICAL SANITARY CROSSING PIPE SHALL CLEAR WALL BY A MINIMUM OF 3".
- 2.) MANHOLE OPENING SHALL NOT BE LOCATED DIRECTLY OVER CONFLICT PIPE.
- 3.) DUCTILE IRON SLEEVE SHALL BE INSTALLED AS CASING FOR CARRIER PIPE.

STORM SEWER CONFLICT MANHOLE DETAIL

N.T.S.

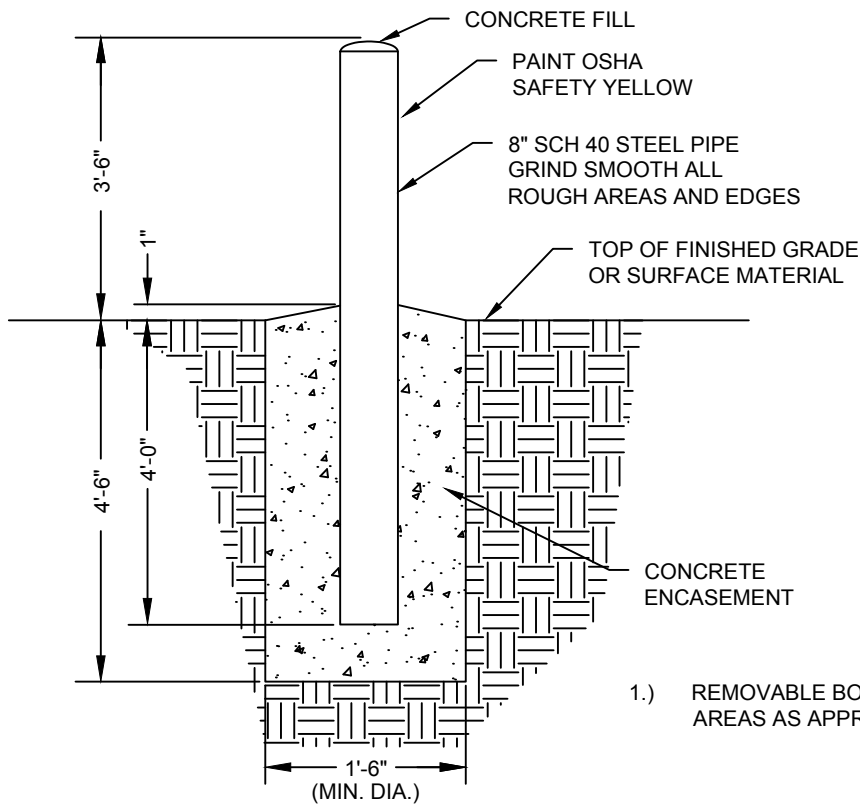

- 1.) REMOVABLE BOLLARDS SHALL BE PERMITTED IN APPROPRIATE AREAS AS APPROVED BY THE CITY ENGINEER.

BOLLARD DETAIL

N.T.S.



CITY OF VENICE
ENGINEERING DEPARTMENT

401 WEST VENICE AVE.
VENICE FL 34285
(941) 486-2626
FAX (941) 480-3031

ENGINEERING

**STORM CONFLICT
MANHOLE & BOLLARD**

DATE
JAN. 2018

SHEET NO.
ENG-9

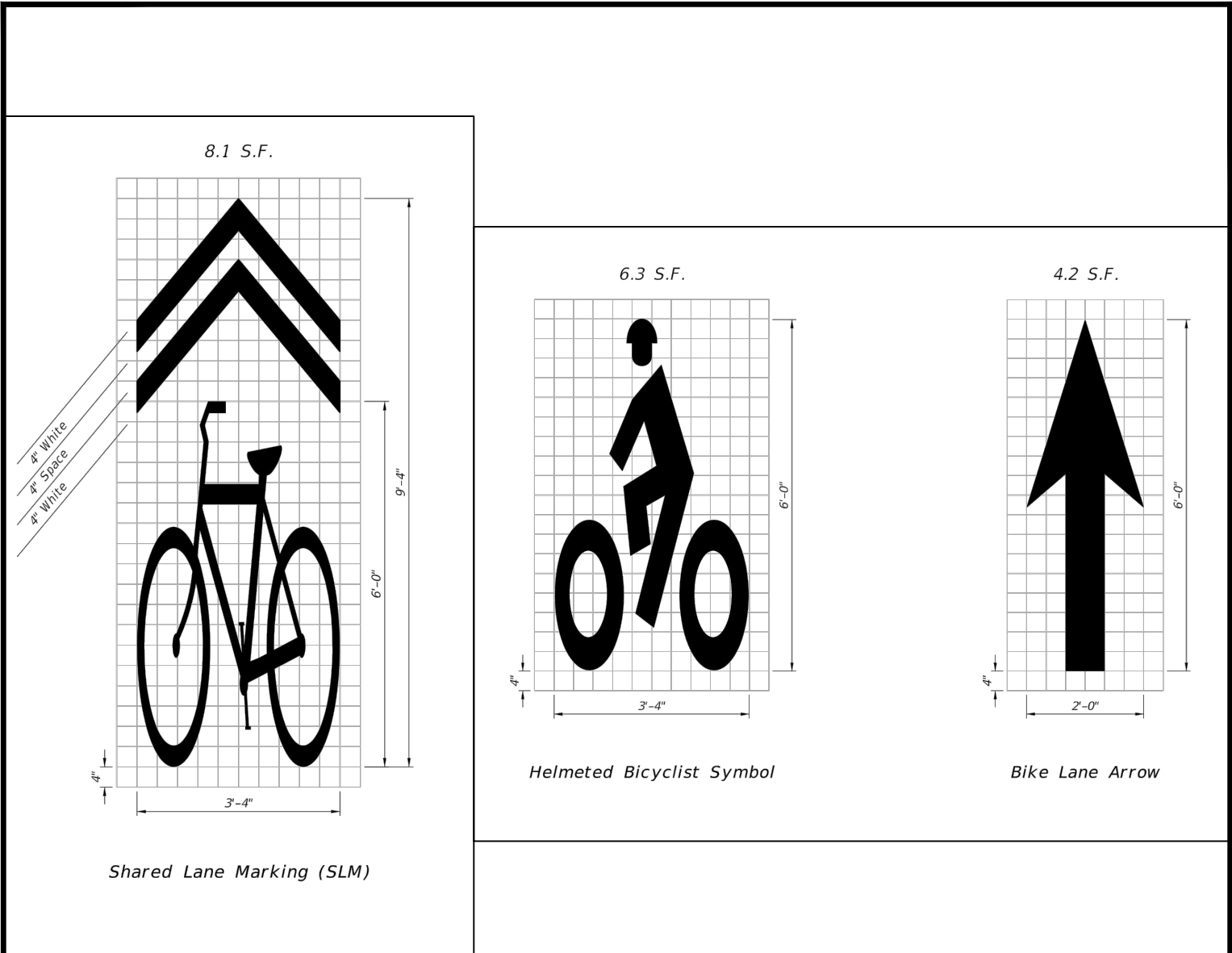

- 1.) SHARED LANE MARKING SHALL BE PLACED IN THE CENTER OF THE TRAFFIC LANE.
- 2.) ALL MARKINGS SHALL BE WHITE IN COLOR AND PREFORMED THERMOPLASTIC.
- 3.) RECOMMENDED PLACEMENT OF BICYCLE LANE MARKINGS:
 - A) AT THE BEGINNING OF A BICYCLE LANE, ON THE FAR SIDE OF INTERSECTIONS AND PRIOR TO AND WITHIN THE BICYCLE LANE KEYHOLE.
 - B) ALONG THE ROADWAY WITH A MAX SPACING OF 1000 FT.
- 4.) RECOMMENDED SPACING FOR SHARED LANE MARKING: IMMEDIATELY AFTER INTERSECTIONS AND AT A MAXIMUM SPACING OF 500 FT.
- 5.) ALL MARKINGS SHALL MEET THE LATEST FDOT DESIGN STANDARDS AND SPECIFICATIONS.

BICYCLE MARKINGS

N.T.S.



CITY OF VENICE
 ENGINEERING DEPARTMENT

401 WEST VENICE AVE.
 VENICE FL 34285
 (941) 486-2626
 FAX (941) 480-3031

ENGINEERING
BICYCLE
MARKINGS

DATE
 JAN. 2018

SHEET NO.
ENG-10

UTILITIES GENERAL DETAILS

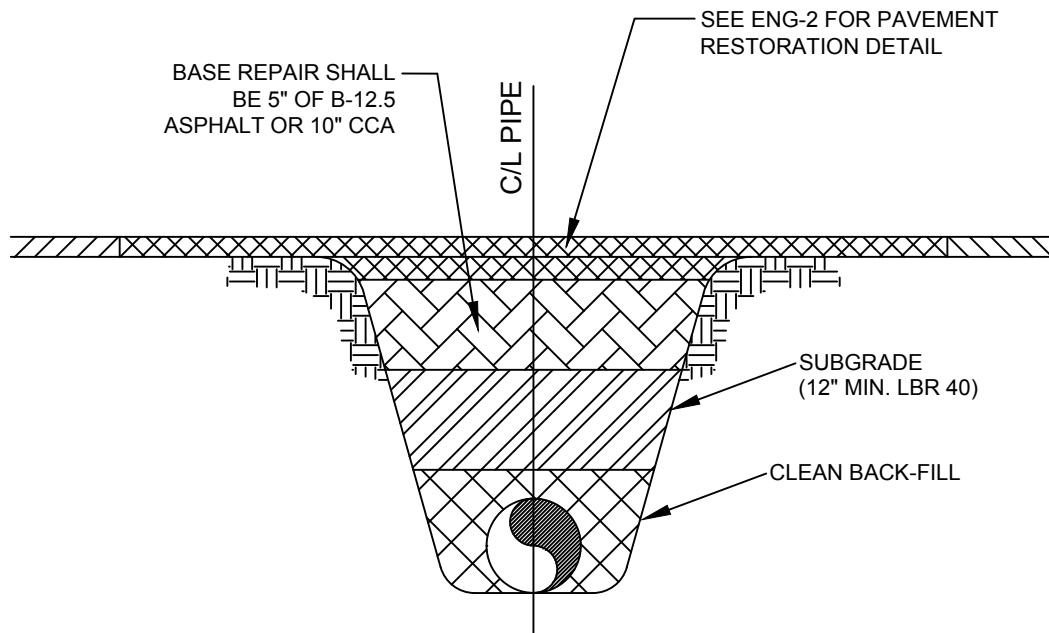

MARKING TAPE AND MESSAGES		
PIPE	TAPE COLOR	MESSAGE
PVC STORM WATER	WHITE	CAUTION STORM WATER OR STORM DRAIN BELOW
POTABLE WATER MAIN	BLUE	CAUTION POTABLE WATER MAIN BELOW
REUSE WATER MAIN	PURPLE	CAUTION REUSE WATER MAIN BELOW
SEWER FORCE MAIN	GREEN	CAUTION SEWER FORCE MAIN BELOW
SEWER & SERVICE LATERALS	GREEN	CAUTION SEWER MAIN BELOW

- 1.) COPPERHEAD TRACING WIRE #12 AWG OR EQUAL SHALL BE ATTACHED TO TOP OF PIPE AT 20' INTERVALS ON ALL RECLAIMED WATER, FORCE, OR POTABLE WATER MAINS. IT SHALL BE COLOR CODED TO REFLECT WHAT THE PIPE CARRIES. (BLUE = WATER, GREEN = SEWER, PURPLE = REUSE)
- 2.) MINIMUM COVER SHALL BE 36" FROM TOP OF PIPE TO FINISHED GRADE. MAXIMUM COVER SHALL BE 42" FROM FINISHED GRADE UNLESS OTHERWISE APPROVED.
- 3.) INSTALLATION OF PIPE SHALL BE IN CONFORMANCE WITH MANUFACTURER'S RECOMMENDATIONS.
- 4.) PAVEMENT RESTORATION SHALL CONFORM WITH DETAIL ENG-2 OF THESE CITY STANDARDS.
- 5.) CONFLICTS - UTILIZE 45° BENDS WITH SEPARATION AS PER CITY DETAILS.
- 6.) ALL UTILITIES (PUBLIC & PRIVATE) THAT CROSS A DITCH/SWALE SHALL BE 36" MIN. BELOW THE ACTUAL/DESIGN BOTTOM OF CONVEYANCE.

PIPE TRENCH DETAIL

N.T.S.



CITY OF VENICE
ENGINEERING DEPARTMENT

401 WEST VENICE AVE.
VENICE FL 34285
(941) 486-2626
FAX (941) 480-3031

UTILITIES - GENERAL

**UTILITY PIPE
TRENCH**

DATE
JAN. 2018

SHEET NO.
U-1

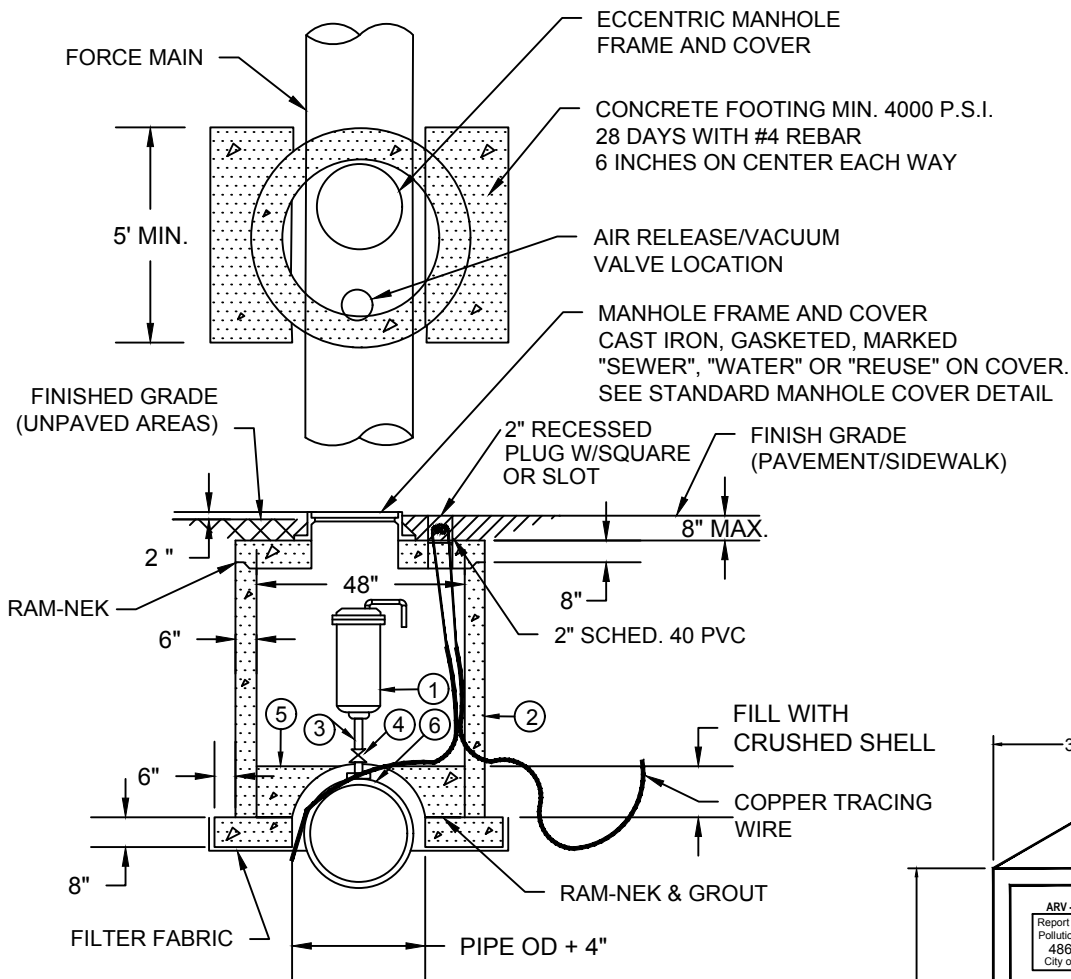

- 1) AUTOMATIC AIR RELEASE WITH BACKWASH ACCESSORIES, MANUFACTURED BY APCO MODEL 400, VAL-MATIC MODEL 48 OR H-TEC MODEL 986 FOR POTABLE & REUSE. WASTEWATER SHALL BE H-TEC MODEL 986 ONLY.
- 2) PRECAST CONCRETE 4 FOOT DIA. MANHOLE OR APPROVED COV STAINLESS STEEL ABOVE GROUND VALVE BOX SECTION WITH TOP SLAB, ASTM C478, LATEST REVISION.
- 3) SS 316 PIPING & SCH 80 FITTINGS
- 4) SS 316 BALL VALVE
- 5) CRUSHED SHELL
- 6) ALL SS DOUBLE BAND SERVICE SADDLE (INCLUDING BODY).
- 7) CAV's SHALL BE PLACED AT THE HIGH POINT OF THE MAIN.
- 8) PIPE CAV's DISCHARGE TO NEAREST GRAVITY SEWER MANHOLE (SEWER & REUSE ONLY).

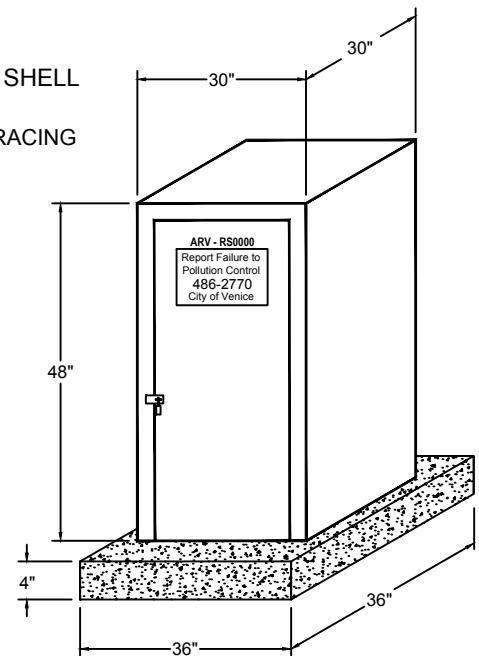

- ABOVE GROUND ARV CONTAINMENT NOTES:
- 1.) 12" HOLE MUST BE IN CENTER OF PAD.
 - 2.) CONTAINMENT BOX MUST BE COMPLETELY CONSTRUCTED OF STAINLESS STEEL.
 - 3.) CONTAINMENT BOX MUST BE EQUIPPED WITH A LOCKABLE DOOR.

AUTOMATIC COMBINATION AIR RELEASE VALVE (CAV) DETAIL

N.T.S.



CITY OF VENICE
ENGINEERING DEPARTMENT

401 WEST VENICE AVE.
VENICE FL 34285
(941) 486-2626
FAX (941) 480-3031

UTILITIES - GENERAL

**AUTO. COMBINATION
AIR RELEASE VALVE**

DATE
JAN. 2018

SHEET NO.
U-2

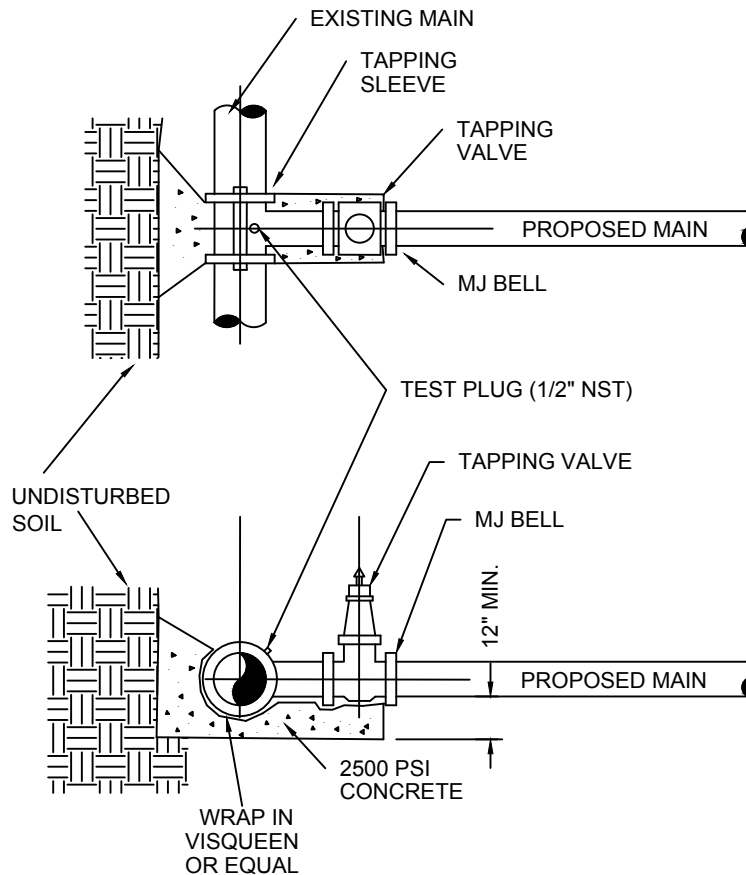

- 1.) EXISTING MAIN SHALL NOT BE TAPPED UNTIL THE ASSEMBLED SLEEVE AND VALVE ARE TESTED IN PLACE AT A MINIMUM OF 150 PSI FOR THIRTY MINUTES.
- 2.) UPON SUCCESSFUL TAPPING SLEEVE PRESSURE TEST (NOTE 1), THE THRUST BLOCK SHALL BE POURED AND HAVE SET FOR 24 HRS PRIOR TO TAPPING. READY-MADE THRUST BLOCKS CAN BE USED WITH CITY APPROVAL.
- 3.) STAINLESS STEEL TAPPING SLEEVE SHALL BE FORD. ALL HARDWARE SHALL BE STAINLESS STEEL. GASKETS SHALL BE VIRGIN SBR COMPOUND.
- 4.) GATE VALVES SHALL BE RESILIENT WEDGE-TYPE MANUFACTURED BY MUELLER OR AMERICAN VALVE. ALL GATE VALVES SHALL BE FUSION BONDED EPOXY COATED (INTERIOR AND EXTERIOR) MEET ANSI/AWWA C550, AND BE NSF61 CERTIFIED.
- 5.) TAPPING SLEEVES MAY ONLY BE USED WHEN THE TAP DIAMETER IS AT LEAST ONE PIPE SIZE SMALLER THAN THE DIAMETER OF THE MAIN BEING TAPPED.

TAPPING SLEEVE & VALVE DETAIL

N.T.S.



CITY OF VENICE
ENGINEERING DEPARTMENT

401 WEST VENICE AVE.
VENICE FL 34285
(941) 486-2626
FAX (941) 480-3031

UTILITIES - GENERAL

**TAPPING SLEEVE
& VALVE**

DATE
JAN. 2018

SHEET NO.
U-3

VALVE SIZE (I.E. 8)
 TYPE (GV)
 SERVICE (REUSE)
 DIRECTION & # OF TURNS TO OPEN (I.E. L-10)
 YEAR INSTALLED (I.E. 2017)

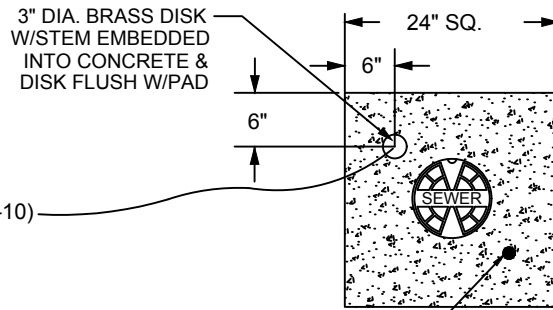

2" RECESSED SQUARE
 FEMALE PLUG
 FOR 12 AWG COPPER
 TRACING WIRE
 PLACED FLUSH W/PAD

PLAN

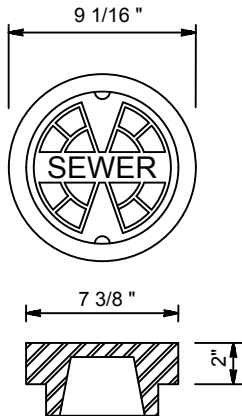

COVER DETAIL

APPROPRIATE SERVICE TYPE
 SHALL BE INDICATED
 (WATER, SEWER OR REUSE)

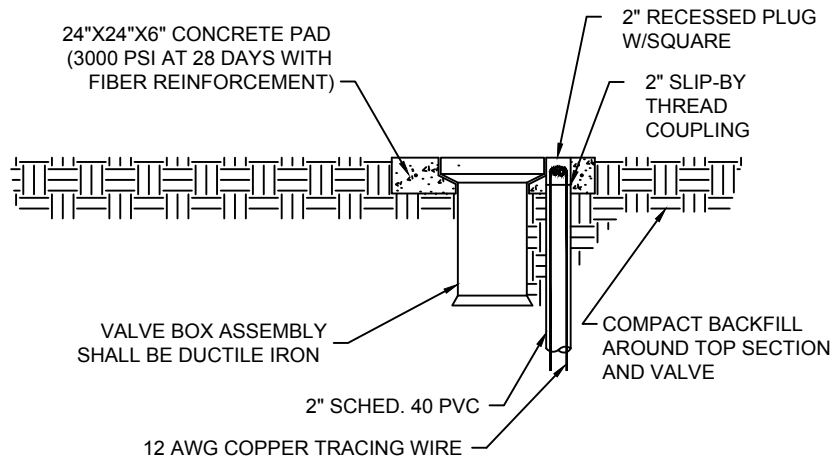

PROFILE

- 1.) PAVED AREAS: SET CONCRETE PAD AND COVER FLUSH WITH FINISHED PAVEMENT SURFACE.
- 2.) UNPAVED AREAS: SET PAD AND COVER 1 INCH ABOVE FINISHED GRADE.
- 3.) VALVES LOCATED IN DITCH AND OVER 4' DEPTH (LINE) MUST USE TRENCH ADAPTER VALVE BOX (AMERICAN FLOW CONTROL).
- 4.) COPPERHEAD TRACING WIRE #12 AWG OR EQUAL SHALL BE USED. IT SHALL BE COLOR CODED TO REFLECT WHAT THE PIPE CARRIES. (BLUE = WATER, GREEN = SEWER, PURPLE = REUSE)
- 5.) PRE-CAST PADS MAY BE USED WITH CITY APPROVAL.
- 6.) FOR CURBED ROADWAYS: CURB SHALL BE ETCHED WITH THE LETTER "V" DIRECTLY PERPENDICULAR TO THE VALVE BOX.

VALVE BOX DETAIL

N.T.S.



CITY OF VENICE
 ENGINEERING DEPARTMENT

401 WEST VENICE AVE.
 VENICE FL 34285
 (941) 486-2626
 FAX (941) 480-3031

UTILITIES - GENERAL

VALVE BOX

DATE
 JAN. 2018

SHEET NO.
 U-4

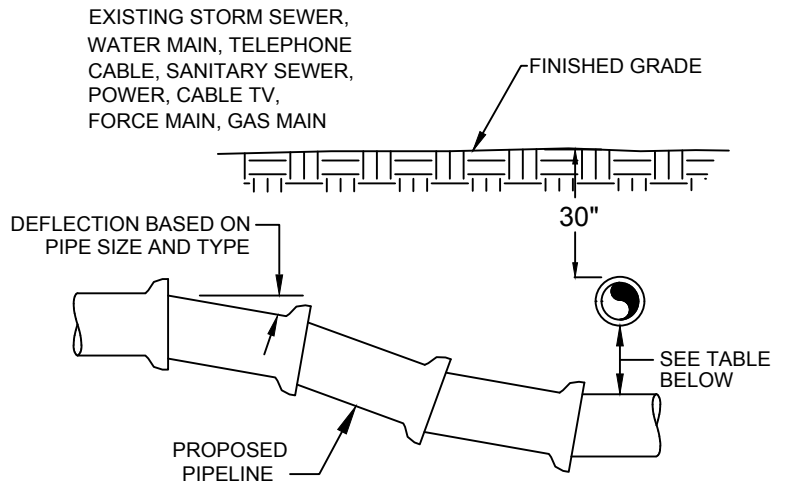
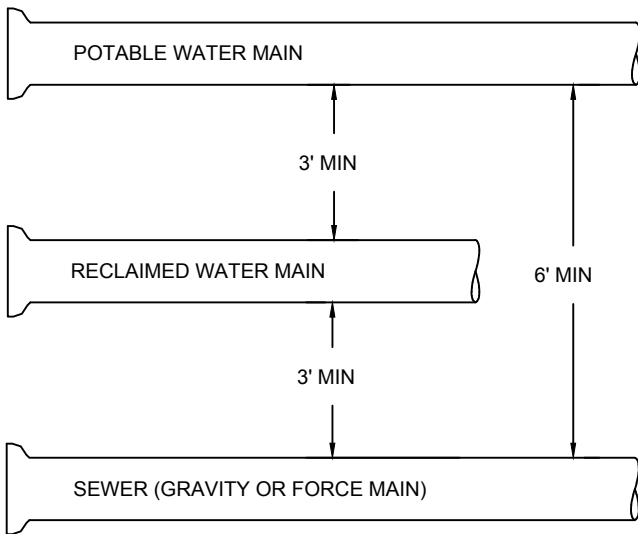

MINIMUM HORIZONTAL SEPARATION DISTANCES (FT)

(OUTSIDE OF PIPELINE TO OUTSIDE OF PIPELINE)

	WATER MAIN	FORCE MAIN	SANITARY SERVICE	REUSE MAIN	STORM WATER	OTHER UTILITIES (TELEPHONE, CABLE, ETC.)
WATER MAIN	3	6	6	3	3	3
FORCE MAIN	6	3	3	3	3	3
SANITARY SEWER	6	3	3	3	3	3
REUSE MAIN	3	3	3	3	3	3
STORM WATER	3	3	3	3	3	3
OTHER UTILITIES	3	3	3	3	3	3

MINIMUM VERTICAL SEPARATION DISTANCES (IN)

(OUTSIDE OF PIPELINE TO OUTSIDE OF PIPELINE)

	WATER MAIN	FORCE MAIN	SANITARY SERVICE	REUSE MAIN	STORM WATER	OTHER UTILITIES (TELEPHONE, CABLE, ETC.)
WATER MAIN	6	12	12	6	6	6
FORCE MAIN	12	6	6	6	6	6
SANITARY SEWER	12	6	6	6	6	6
REUSE MAIN	6	6	6	6	6	6
STORM WATER	6	6	6	6	6	6
OTHER UTILITIES	6	6	6	6	6	6

- 1.) MAXIMUM JOINT DEFLECTION SHALL BE 90% OF MANUFACTURER'S RECOMMENDATION.
- 2.) WHEREVER POSSIBLE, THE LAYOUT OF UTILITIES SHALL PLACE SANITARY SEWER AND SEWER FORCE MAINS BELOW RECLAIMED MAINS AND BELOW WATER MAINS, RESPECTIVELY. WHERE WATER MAINS ARE ABOVE GRAVITY SEWERS OR WASTEWATER FORCE MAINS, A VERTICAL CLEARANCE OF 6 INCHES IS ACCEPTABLE.
- 3.) ACCEPTABLE VARIANCES:
 - A. WHERE HORIZONTAL SEPARATION CANNOT BE MAINTAINED, C900 DR14 PVC PIPE SHALL BE USED FOR ONE OF THE PIPELINES.
 - B. WHERE VERTICAL CLEARANCE CANNOT BE MAINTAINED, ONE FULL LENGTH OF DR14 C900 PIPE SHALL BE INSTALLED CENTERED AT THE POINT OF CROSSING.
 - C. WHERE 36" MINIMUM DEPTH OF COVER CANNOT BE MAINTAINED, SPECIAL PROTECTION OR PIPE MATERIAL UPGRADE MAY BE REQUIRED, AT THE DISCRETION OF THE UTILITY DEPARTMENT.
- 4.) NO WATER PIPE SHALL PASS THROUGH, OR COME IN CONTACT WITH ANY PART OF A SANITARY MANHOLE OR STORMWATER STRUCTURE.

UTILITY CONFLICT & SEPARATION DETAIL

N.T.S.



CITY OF VENICE
ENGINEERING DEPARTMENT

401 WEST VENICE AVE.
VENICE FL 34285
(941) 486-2626
FAX (941) 480-3031

UTILITIES - GENERAL

**UTILITY CONFLICTS
& SEPARATIONS**

DATE
JAN. 2018

SHEET NO.
U-5

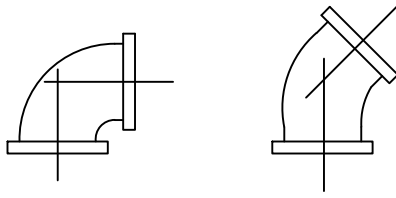

- 1.) ALL PIPE FITTINGS SHALL BE COMPACT, DUCTILE IRON.
- 2.) ALL APPLICATIONS (RAW, POTABLE, REUSE, SEWER) SHALL BE FUSION BONDED EPOXY COATED INSIDE AND OUT.
- 3.) ALL FITTINGS SHALL MEET ANSI/AWWA C116/A21.16 STANDARDS.

PIPE FITTINGS

N.T.S.

SERVICE	COLOR	MATERIAL/CLASS
POTABLE WATER MAIN	BLUE	AWWA C900 PVC / DR 18 FUSIBLE C900 PVC / DR 18 HDPE PPI PE 3408 / DR 11 (DUCTILE IRON PIPE SIZE)
RAW WATER MAIN	WHITE	
REUSE MAIN	PURPLE	
FORCE MAIN (MIN. 4" DIAMETER)	GREEN	
WATER SERVICE	BLUE	PE (POLYTUBING) / DR 9
REUSE SERVICE	PURPLE	PE (POLYTUBING) / DR 9
GRAVITY SEWER MAIN (MIN. 8" DIAMETER)	GREEN	ASTMD3034 / SDR 26 FUSIBLE PVC / SDR 26
SEWER LATERAL (MIN. 6" DIAMETER)	GREEN	ASTMD3034 / SDR 26 / SDR 35 / SCH 40 PVC

PIPE MATERIAL SCHEDULE

N.T.S.



CITY OF VENICE
ENGINEERING DEPARTMENT

401 WEST VENICE AVE.
VENICE FL 34285
(941) 486-2626
FAX (941) 480-3031

UTILITIES - GENERAL

**PIPE FITTINGS &
MATERIAL**

DATE
JAN. 2018

SHEET NO.
U-6

MINIMUM LENGTH (FT) OF FORCE MAIN TO BE RESTRAINED ON EACH SIDE OF FITTING										
FITTING	PIPE SIZE (INCHES)									
	4	6	8	10	12	16	18	20	24	
45 BEND:	H	6	9	12	14	16	21	23	25	29
	VU	4	6	7	9	10	13	15	16	19
	VD	12	20	26	32	37	48	53	28	68
22.5 BEND:	H	3	4	6	7	8	10	11	12	14
	VU	2	3	4	4	5	6	7	8	9
	VD	7	10	13	15	18	23	26	28	33
11.25 BEND:	H	2	2	3	3	4	5	5	6	7

MINIMUM LENGTH (FT) OF WATER OR REUSE MAIN TO BE RESTRAINED ON EACH SIDE OF FITTING										
FITTING	PIPE SIZE (INCHES)									
	4	6	8	10	12	16	18	20	24	
90 BEND:	H	23	33	43	51	60	76	83	90	104
45 BEND:	H	10	14	18	21	25	31	34	37	43
	VU	6	8	11	13	16	20	22	24	28
	VD	22	30	40	48	56	72	80	87	102
22.5 BEND:	H	5	7	8	10	12	15	17	18	21
	VU	3	4	5	6	7	10	11	12	14
	VD	10	15	19	23	27	35	38	42	49
11.25 BEND:	H	2	3	4	5	6	7	8	9	10
PLUGS:		52	73	96	115	136	174	193	211	246

ABBREVIATIONS: H=HORIZONTAL, VU=VERTICAL UP, VD=VERTICAL DOWN.

- FOR TEE OR REDUCER FITTINGS SUBMIT RESTRAINED JOINT LENGTH CALCULATIONS TO CITY ENGINEER FOR REVIEW AND APPROVAL, USING THE ASSUMPTIONS LISTED ABOVE.
- RESTRAINED JOINT LENGTH FOR WATER AND REUSE MAINS BASED ON TEST PRESSURE OF 150 PSI. RESTRAINED JOINT LENGTH FOR FORCE (SEWER) MAINS BASED ON TEST PRESSURE OF 100 PSI. CALCULATIONS WERE MADE USING EBAA IRON SOFTWARE (AVAILABLE AT WWW.EBAA.COM) AND THE FOLLOWING ASSUMPTIONS: GRANULAR MATERIAL (GM) SOIL TYPE, TRENCH TYPE 3, BURY DEPTH OF 3 FT, AND SAFETY FACTOR OF 2 TO 1. IF FIELD CONDITIONS DIFFER FROM ABOVE ASSUMPTIONS EOR SHALL PROVIDE CALCULATIONS BASED ON ACTUAL CONDITIONS.
- RESTRAINED JOINT SHALL BE USED ON ALL JOINTS FROM ANY MAIN TEE TO ANY FIRE HYDRANT ASSEMBLY.
- THRUST BLOCKS WILL NOT BE ACCEPTED, UNLESS OTHERWISE APPROVED BY THE CITY ENGINEER.

PRESSURE MAIN RESTRAINED JOINT TABLE

N.T.S.



CITY OF VENICE
ENGINEERING DEPARTMENT

401 WEST VENICE AVE.
VENICE FL 34285
(941) 486-2626
FAX (941) 480-3031

UTILITIES - GENERAL

**RESTRAINED
JOINT TABLE**

DATE
JAN. 2018

SHEET NO.
U-7

UTILITIES

WATER DETAILS

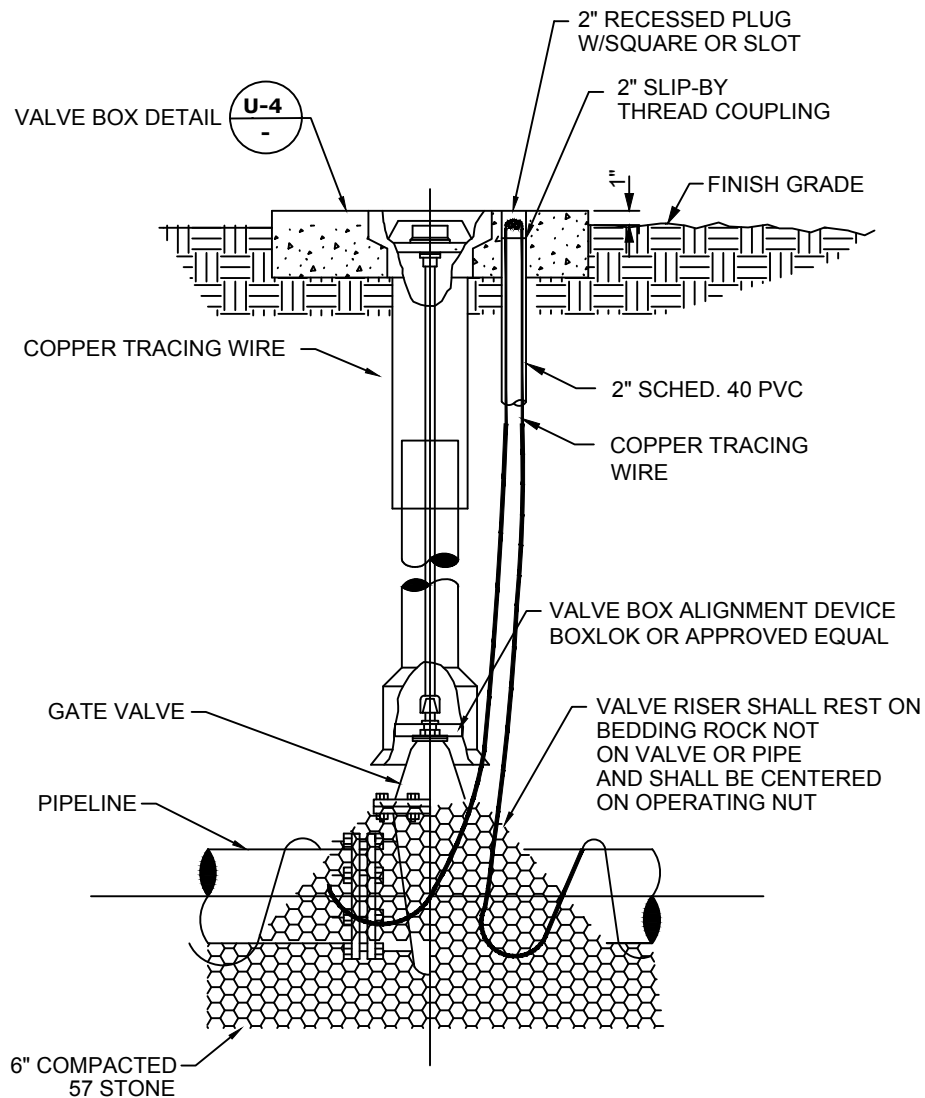

- 1.) GATE VALVES SHALL BE RESILIENT WEDGE-TYPE MANUFACTURED BY MUELLER, AMERICAN VALVE, OR EQUAL. ALL GATE VALVES SHALL BE FUSION BONDED EPOXY COATED (INTERIOR AND EXTERIOR) MEET ANSI/AWWA C550, AND BE NSF61 CERTIFIED.
- 2.) FOR VALVES LARGER THAN 12" IN USE BUTTERFLY STYLE VALVE.
- 3.) VALVE SHALL BE INSTALLED IN CONFORMANCE WITH MANUFACTURER'S RECOMMENDATIONS.
- 4.) COPPERHEAD TRACING WIRE PART #12 AWG OR EQUAL SHALL BE USED. IT SHALL BE COLOR CODED TO REFLECT WHAT THE PIPE CARRIES. (BLUE = WATER, PURPLE = REUSE)
- 5.) FOR CURBED ROADWAYS: CURB SHALL BE ETCHED WITH THE LETTER "V" DIRECTLY PERPENDICULAR TO THE VALVE BOX.

GATE VALVE DETAIL

(WATER AND REUSE ONLY)
N.T.S.



CITY OF VENICE
ENGINEERING DEPARTMENT

401 WEST VENICE AVE.
VENICE FL 34285
(941) 486-2626
FAX (941) 480-3031

UTILITIES - WATER

GATE VALVE

DATE
JAN. 2018

SHEET NO.
W-1

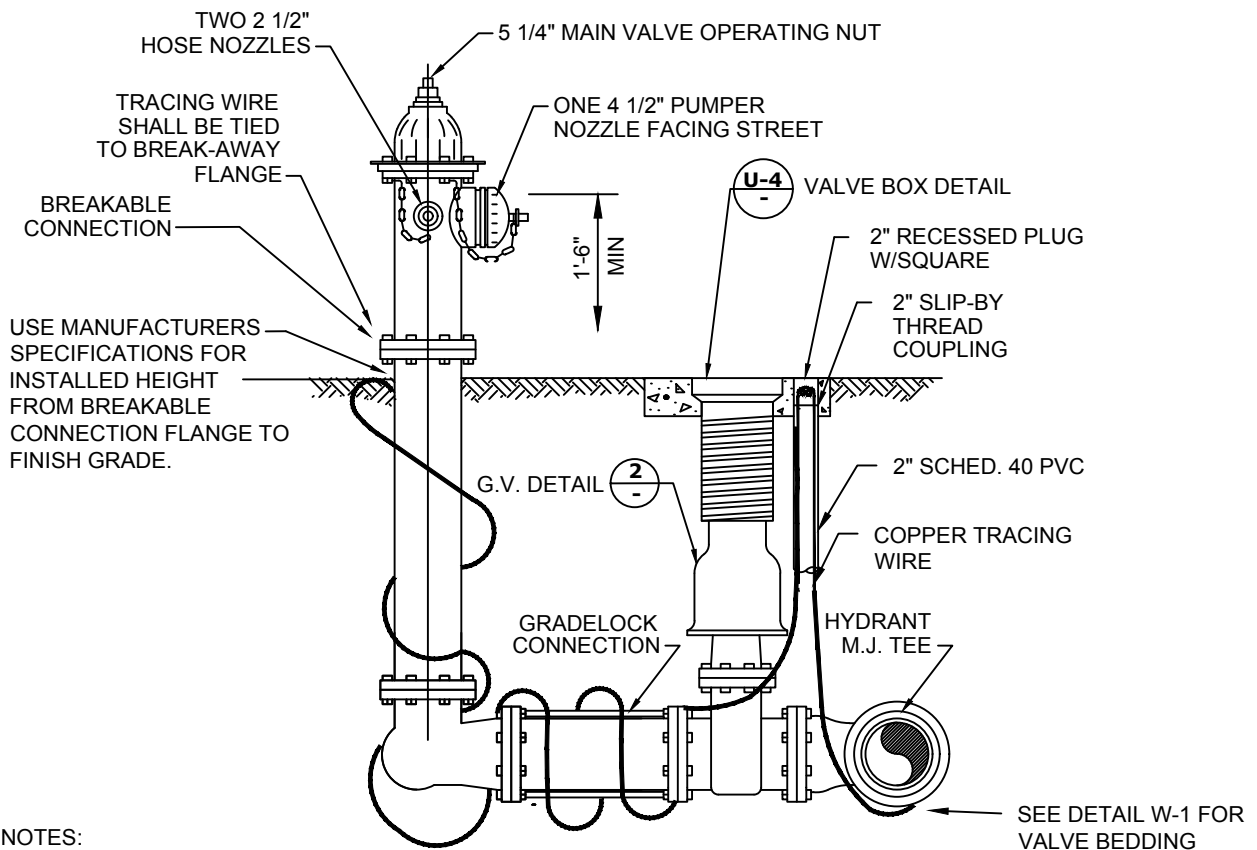

NOTES:

- 1.) POTABLE WATER FIRE HYDRANTS SHALL BE PAINTED "SAFETY YELLOW".
- 2.) REUSE FIRE HYDRANTS SHALL BE PAINTED PANTONE PURPLE 522C AND TAGGED WITH A PERMANENT LABEL "RECLAIMED WATER-DO NOT DRINK."
- 3.) HYDRANT SHALL BE MUELLER SUPER CENTURIAN MODEL A423, AMERICAN B84BV WITH BREAK-AWAY FEATURE. ALL BOLTS SHALL BE SS (BONNET, SAFETY FLANGE, SHOE).
- 4.) RESTRAINED JOINTS SHALL BE USED BETWEEN TEE AND HYDRANT.
- 5.) HYDRANTS SHALL HAVE "OUT OF SERVICE" TAGS AND BE BAGGED UNTIL MAINS ARE ACCEPTED BY CITY.
- 6.) ALL WEEP HOLES SHALL BE PLUGGED.
- 7.) HYDRANT LOCATED AT LEAST 3' OR MORE FROM ANY STORM WATER PIPE OR DITCH AND AT LEAST 6' OR MORE FROM ANY SANITARY SEWER STRUCTURE.
- 8.) FOR CLEARANCE ISSUES, PLEASE REFER TO CURRENT FLORIDA FIRE PREVENTION CODE REQUIREMENTS.
- 9.) COPPERHEAD TRACING WIRE #12 AWG OR EQUAL SHALL BE USED. IT SHALL BE COLOR CODED TO REFLECT WHAT THE PIPE CARRIES. (BLUE = WATER, PURPLE = REUSE)
- 10.) ASSEMBLY SHALL BE BEDDED IN 8" OF CRUSHED SHELL AND INSTALLED AT PROPER BURIAL DEPTH.
- 11.) FIRE HYDRANT ASSEMBLY INCLUDES GATE VALVE.
- 12.) GRADELOCK CONNECTION TO BE USED BETWEEN VALVE AND HYDRANT. FUSION BONDED EPOXY. ROTATE TO FINAL GRADE.

FIRE HYDRANT ASSEMBLY DETAIL

N.T.S.



CITY OF VENICE
ENGINEERING DEPARTMENT

401 WEST VENICE AVE.
VENICE FL 34285
(941) 486-2626
FAX (941) 480-3031

UTILITIES - WATER

**FIRE HYDRANT
ASSEMBLY**

DATE
JAN. 2018

SHEET NO.
W-2

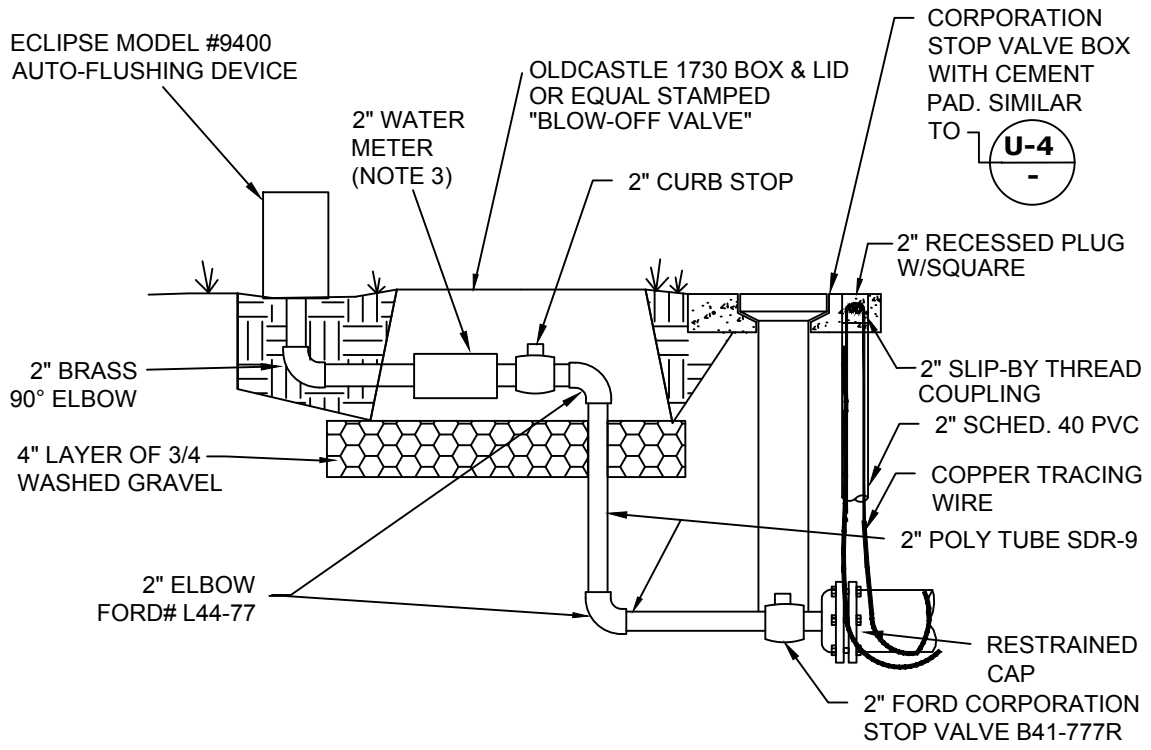

- 1.) FOR ALL DEAD-END WATER MAINS.
- 2.) AUTOMATIC FLUSHING DEVICE SHALL BE AN ECLIPSE MODEL #9400.
- 3.) CONTRACTOR SHALL PROVIDE 2" BADGER MODEL-170 R.R. METER, HRE REGISTER, ORION MESE ENDPOINT.
- 4.) COPPERHEAD TRACING WIRE PART #12 AWG OR EQUAL SHALL BE USED.

AUTOMATIC FLUSHING DEVICE DETAIL

N.T.S.

 <p style="font-size: small;">Venice, Florida "City on the Gulf"</p>	<p>CITY OF VENICE ENGINEERING DEPARTMENT</p> <p>401 WEST VENICE AVE. VENICE FL 34285 (941) 486-2626 FAX (941) 480-3031</p>	<p>UTILITIES - WATER</p> <hr/> <p>AUTOMATIC FLUSHING DEVICE</p>	<p>DATE JAN. 2018</p> <hr/> <p>SHEET NO. W-3</p>

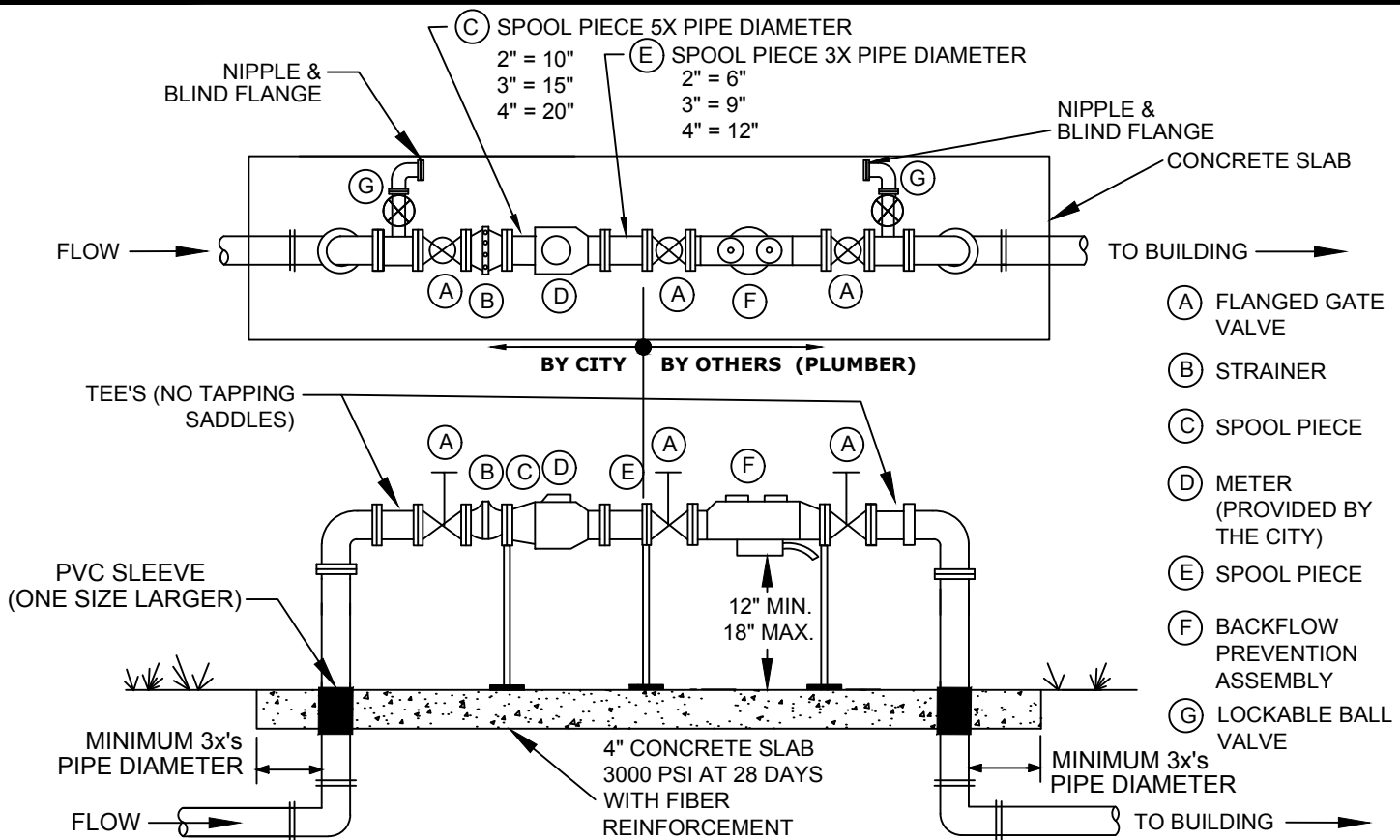

- 1.) EITHER 90°-DEGREE OR 45°-DEGREE FITTINGS MAY BE USED WITH THE REQUIRED LENGTH OF RESTRAINED JOINT FITTINGS.
- 2.) BACKFLOW PREVENTION ASSEMBLY TYPE SHALL BE DETERMINED BY THE CITY OF VENICE UTILITIES DEPARTMENT'S MOST CURRENT CROSS-CONNECTION CONTROL PROGRAM.
- 3.) ALL BACKFLOW PREVENTION ASSEMBLIES SHALL BE APPROVED BY THE UNIVERSITY OF SOUTHERN CALIFORNIA FOUNDATION FOR CROSS-CONNECTION CONTROL AND HYDRAULIC RESEARCH AND/OR ASSE 1013.
- 4.) ALL CONCRETE PIPE PENETRATIONS SHALL BE PROTECTED WITH A PVC SLEEVE, ONE SIZE LARGER THAN RISER PIPE.
- 5.) VALVES SHALL BE FULL PORTED FULL FLOW BALL VALVES OR RESILIENT WEDGE NON-RISING STEM GATE VALVES.
- 6.) ALL METERS 1 1/2 & UP WILL HAVE FLANGES. LAY LENGTHS MUST BE VERIFIED PRIOR TO CONSTRUCTION OF ASSEMBLIES.
- 7.) PIPE BETWEEN TAP & ISOLATION VALVE SHALL BE C900 PVC.
- 8.) THE WATER METER SHALL MATCH THE BACKFLOW AND ASSEMBLY PIPE SIZE.
- 9.) 2" AND SMALLER METERS REQUIRE A LOCKABLE CURB STOP. LARGER THAN 2" METERS WILL HAVE A FLANGED WHEEL HANDLE RESILIENT WEDGE GATE VALVE.
- 10.) NO SPOOL PIECE REQUIRED FOR 3/4", 1", OR 1 1/2".
- 11.) ALL COMMERCIAL AND MULTI FAMILY UNIT METERS MUST BE ABOVE GRADE. REUSE METERS 2" AND LESS MAY BE BELOW GROUND.
- 12.) BACKFLOW PREVENTION ASSEMBLY AND BYPASS ARE NOT REQUIRED FOR REUSE METER ONLY.
- 13.) BACKFLOW PREVENTION ASSEMBLIES SHALL ONLY BE BY-PASSED IF A TEMPORARY RP IS INSTALLED ON BY-PASS.
- 14.) NO BRANCH OR TEE SERVICE CONNECTIONS, OTHER THAN THE UTILITIES METER BY-PASS RETURN TEE, SHALL EXIST BETWEEN THE WATER METER AND BACKFLOW PREVENTER.
- 15.) THE ENGINEER OF RECORD SHALL SUBMIT METER SIZING CALCULATIONS BASED ON SERVICE DEMAND PER AWWA M-22 AND SUBJECT TO APPROVAL BY THE UTILITY DEPARTMENT.
- 16.) PARALLEL BACKFLOW ASSEMBLY MAY BE PERMITTED TO ALLOW FOR UNINTERRUPTED SERVICE AND SHALL PROVIDE THE SAME DEGREE OF PROTECTION OR GREATER.

METER SIZE (IN.)	BY-PASS SIZE
3/4"	NO BYPASS
1"	NO BYPASS
1 1/2"	1"
2"	1 1/2"
3"	2"
4"	3"

WATER & REUSE METER & BACKFLOW PREVENTION ASSEMBLY
ABOVE GROUND COMMERCIAL/MULTI-UNIT/SINGLE SERVICE/MASTER METER
(WITH BY-PASS AROUND METER ONLY) N.T.S.



CITY OF VENICE
ENGINEERING DEPARTMENT

401 WEST VENICE AVE.
VENICE FL 34285
(941) 486-2626
FAX (941) 480-3031

UTILITIES - WATER

**WATER & REUSE
METER & BACKFLOW**

DATE
JAN. 2018

SHEET NO.
W-4

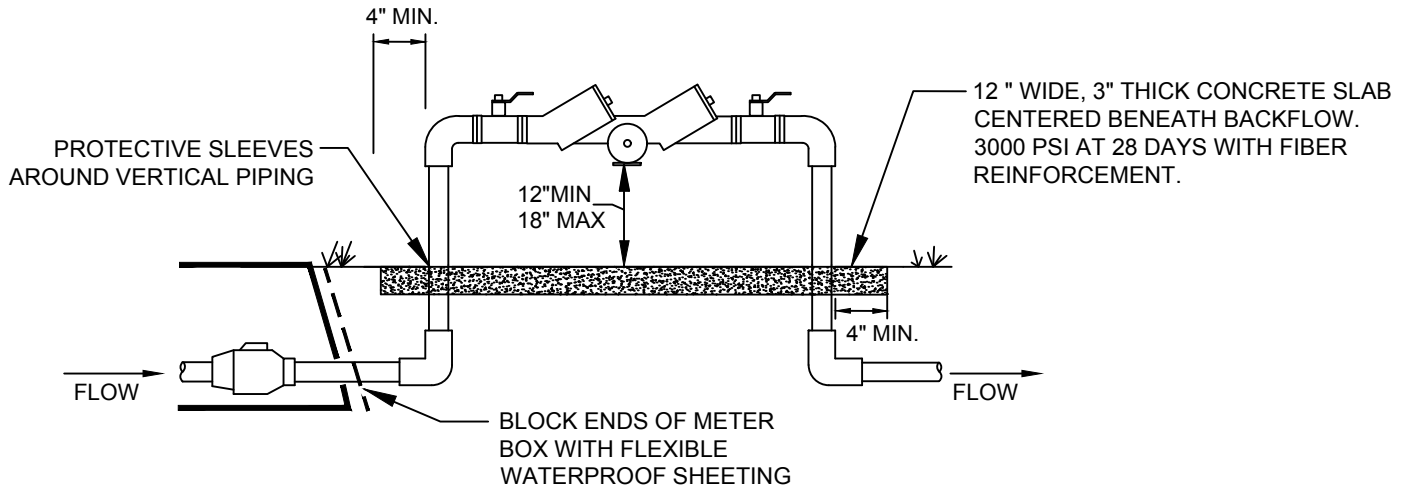

- 1.) BACKFLOW PREVENTION ASSEMBLY TYPE SHALL BE DETERMINED BY THE CITY OF VENICE UTILITIES DEPARTMENT'S MOST CURRENT CROSS-CONNECTION CONTROL PROGRAM.
- 2.) ALL BACKFLOW PREVENTION ASSEMBLIES SHALL BE APPROVED BY THE UNIVERSITY OF SOUTHERN CALIFORNIA FOUNDATION FOR CROSS-CONNECTION CONTROL AND HYDRAULIC RESEARCH AND/OR ASSE 1013.
- 3.) ALL ABOVE GROUND PIPING SHALL BE RIGID COPPER.
- 4.) THE WATER METER AND BACKFLOW PREVENTER SHALL BE THE SAME SIZE.
- 5.) INSTALLED IMMEDIATELY AFTER THE UTILITY WATER METER UNLESS OTHERWISE APPROVED BY THE CITY OF VENICE UTILITIES DEPARTMENT.
- 6.) NO BRANCH OR TEE CONNECTIONS SHALL EXIST BETWEEN THE WATER METER AND BACKFLOW PREVENTER.
- 7.) ALL METER BOXES SHALL BE SET FLUSH WITH FINISHED GRADE.
- 8.) SHEETING SHALL BE A PVC TYPE MATERIAL WITH A MINIMUM OF 40 MIL. THICKNESS.
- 9.) PROTECTIVE SLEEVES MAY BE PVC PIPE ONE SIZE LARGER THAN RISER OR OTHER CITY APPROVED MATERIAL.

BACKFLOW PREVENTION ASSEMBLY

(RESIDENTIAL, NOT MASTER METERED)

N.T.S.



CITY OF VENICE
ENGINEERING DEPARTMENT

401 WEST VENICE AVE.
VENICE FL 34285
(941) 486-2626
FAX (941) 480-3031

UTILITIES - WATER

**BACKFLOW ASSEMBLY
(NO MASTER METER)**

DATE
JAN. 2018

SHEET NO.
W-5

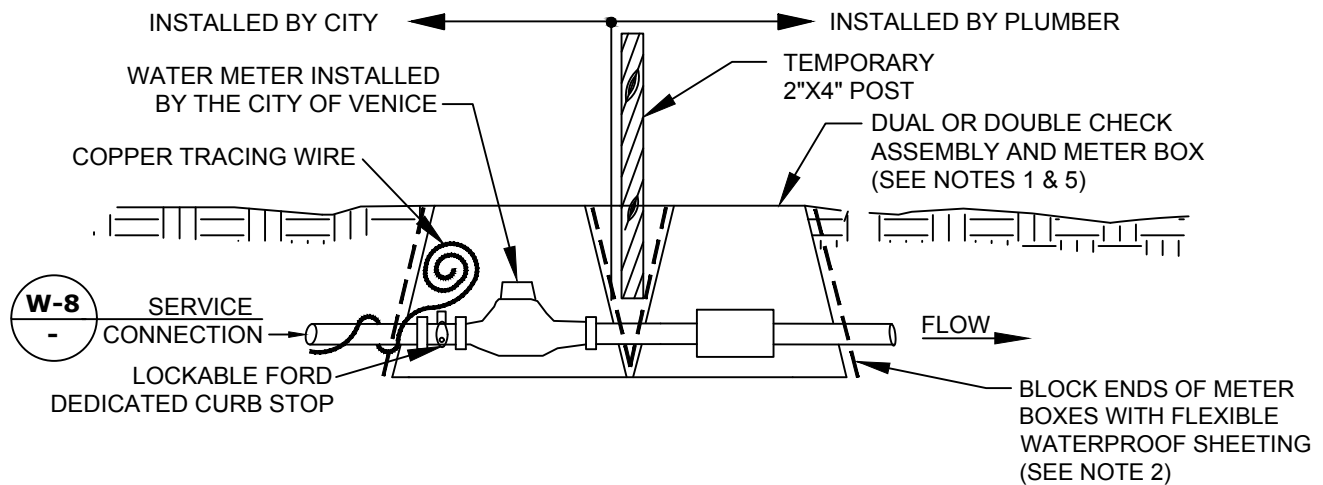

- 1.) THE POTABLE WATER SYSTEM SHALL USE A BROOKS MODEL# 1220 BLACK PLASTIC METER BOX WITH METAL READER AND BLACK SOLID RODS OR APPROVED EQUAL FOR BOTH METER AND CHECK VALVE.
- 2.) CENTER METER IN BOX AND BLOCK ENDS OF BOX TO PREVENT DIRT FROM ENTERING WITH FLEXIBLE WATERPROOF SHEETING. SHEETING SHALL BE A PVC TYPE MATERIAL WITH MINIMUM 40 MIL THICKNESS.
- 3.) COPPERHEAD TRACING WIRE #12 AWG OR EQUAL SHALL BE USED AND COLOR CODED TO REFLECT WHAT THE PIPE CARRIES (BLUE = WATER).
- 4.) LOCKING CURB STOP MUST BE LOCATED IN BOX AND SHALL BE LOCKED IN THE CLOSED POSITION WITH A LOCK SUPPLIED BY THE UTILITIES DEPARTMENT AT THE TIME OF SERVICE LINE INSTALLATION. LOCK TO BE REMOVED BY THE UTILITIES DEPARTMENT ONLY AFTER STANDARD DETAIL REQUIREMENTS ARE MET. DEDICATED FIRE SERVICE CURB STOPS SHALL BE LOCKED IN THE OPEN POSITION BY THE UTILITIES DEPARTMENT AFTER STANDARD DETAIL REQUIREMENTS ARE MET. ALL CURB STOPS SHALL BE ORIENTED WITH THE OPERATING NUT ON TOP AND ACCESSIBLE FOR SERVICE BY A CURB STOP KEY.
- 5.) DUAL OR DOUBLE CHECK ASSEMBLY, WHEN REQUIRED BY THE CITY OF VENICE UTILITIES DEPARTMENT'S MOST CURRENT CROSS-CONNECTION CONTROL PROGRAM, SHALL BE INSTALLED BY A PLUMBER IN A SEPARATE BOX IMMEDIATELY AFTER THE WATER METER BOX. TEST PORTS SHALL BE PLUGGED WITH NON-METALLIC OR PLASTIC PLUGS.
- 6.) RESIDENTIAL FIRE SERVICE SPRINKLERS INCORPORATED INTO DOMESTIC RESIDENTIAL PLUMBING SHALL BE SERVICED BY AN ELECTRONIC WATER METER MEETING NFPA STANDARDS FOR FLOW AND PRESSURE LOSS.
- 7.) THE ENGINEER OF RECORD SHALL SUBMIT METER SIZING CALCULATIONS BASED ON SERVICE DEMAND PER AWWA M-22 AND SUBJECT TO APPROVAL BY THE UTILITIES DEPARTMENT.
- 8.) ALL METER BOXES SHALL BE SET FLUSH WITH FINISHED GRADE.

RESIDENTIAL WATER & FIRE METER

(RESIDENTIAL USE ONLY)

N.T.S.



CITY OF VENICE
ENGINEERING DEPARTMENT

401 WEST VENICE AVE.
VENICE FL 34285
(941) 486-2626
FAX (941) 480-3031

UTILITIES - WATER

**RESIDENTIAL WATER &
FIRE METER**

DATE
JAN. 2018

SHEET NO.
W-6

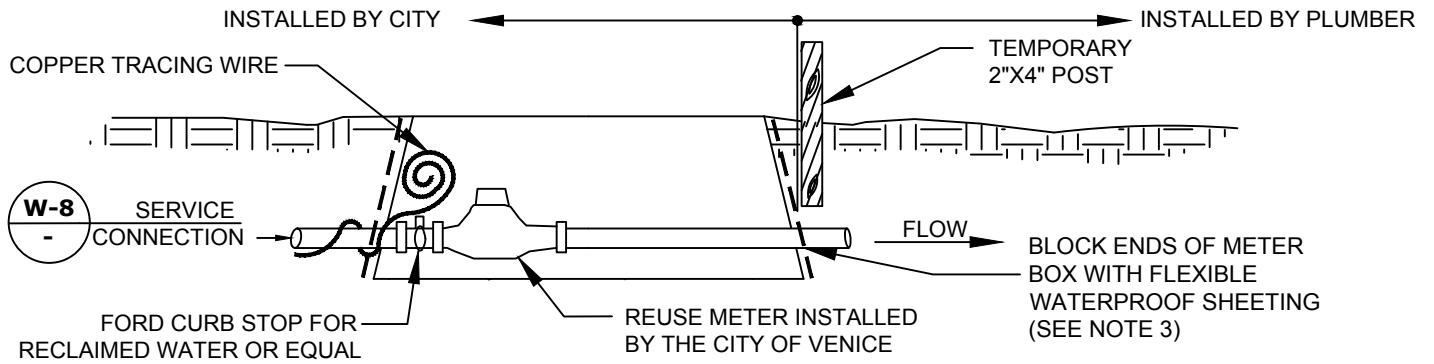

- 1.) THE REUSE SYSTEM SHALL USE A BROOKS # 1419 OR APPROVED EQUAL, THE LID SHALL BE STAMPED "NON-POTABLE" & "DO NOT DRINK" IN BOTH ENGLISH AND SPANISH AND MUST BE LOCKABLE, METER BOX AND LID SHALL BE PURPLE (COLOR PANTONE 522C).
- 2.) CURB STOP MUST BE LOCATED INSIDE THE METER BOX AND SHALL BE LOCKED IN THE CLOSED POSITION WITH A LOCK SUPPLIED BY THE UTILITIES DEPARTMENT AT THE TIME OF SERVICE LINE INSTALLATION. LOCK TO BE REMOVED BY THE UTILITIES DEPARTMENT ONLY AFTER STANDARD DETAIL REQUIREMENTS ARE MET. ALL CURB STOPS SHALL BE ORIENTED WITH THE OPERATING NUT ON TOP AND ACCESSIBLE FOR SERVICE BY A CURB STOP KEY.
- 3.) CENTER METER IN BOX AND BLOCK ENDS OF BOX TO PREVENT DIRT FROM ENTERING WITH FLEXIBLE WATERPROOF SHEETING. SHEETING SHALL BE A PVC TYPE MATERIAL WITH MINIMUM 40 MIL THICKNESS.
- 4.) COPPERHEAD TRACING WIRE #12 AWG OR EQUAL SHALL BE USED. IT SHALL BE COLOR CODED TO REFLECT WHAT THE PIPE CARRIES. (PURPLE = REUSE)
- 5.) ALL METER BOXES SHALL BE SET FLUSH WITH FINISHED GRADE.

REUSE METER

RESIDENTIAL & COMMERCIAL 2" AND BELOW

N.T.S.

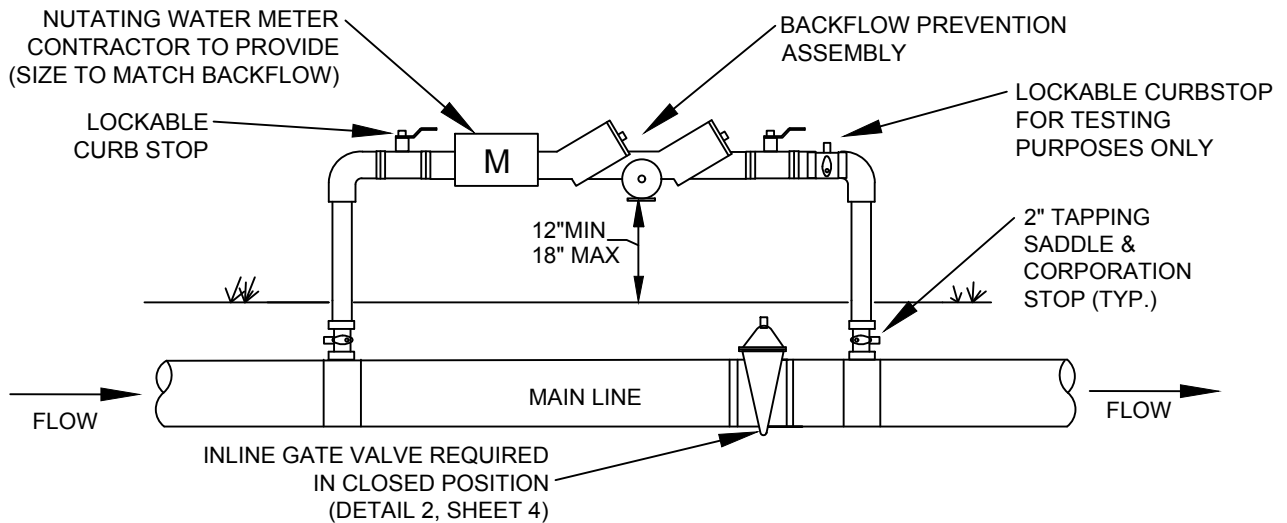

- 1.) BACKFLOW PREVENTION ASSEMBLY MUST BE CERTIFIED WITHIN THE PAST YEAR.
- 2.) INLINE MAIN VALVE MUST REMAIN CLOSED UNTIL FINAL CITY TURNOVER IS COMPLETE AND FDEP CLEARANCE IS ISSUED.
- 3.) JUMPER ASSEMBLY SHALL BE REMOVED ONCE MAIN LINE IS CLEARED AND TURNED OVER TO CITY.
- 4.) DURING JUMPER REMOVAL, CORPORATION STOPS SHALL BE SHUT OFF AND PLUGGED WITH LEAD FREE BRASS PLUGS.

TEMPORARY MAIN-LINE JUMPER DETAIL

N.T.S.



CITY OF VENICE
ENGINEERING DEPARTMENT

401 WEST VENICE AVE.
VENICE FL 34285
(941) 486-2626
FAX (941) 480-3031

UTILITIES - WATER

**REUSE METER &
TEMPORARY JUMPER**

DATE
JAN. 2018

SHEET NO.
W-7

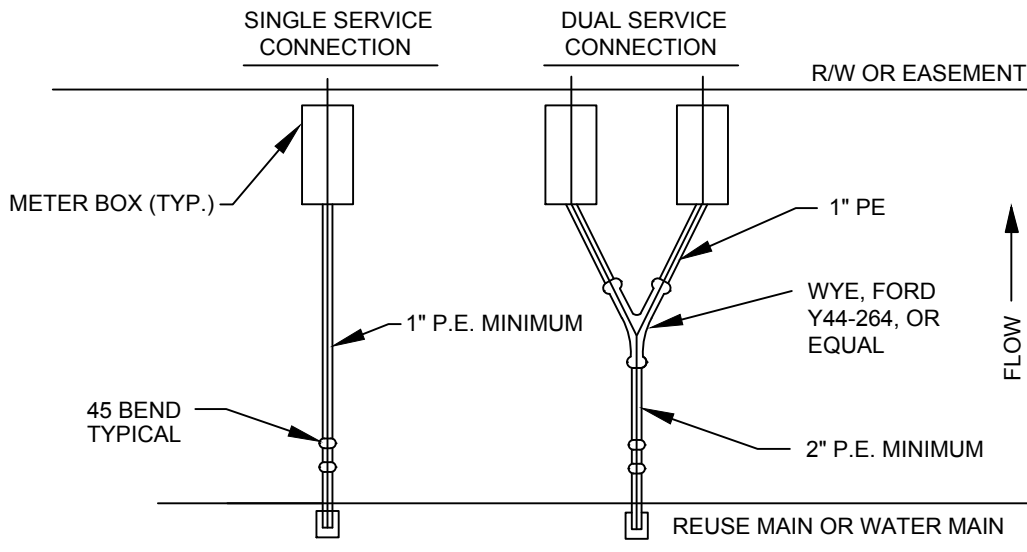

RESIDENTIAL METER CONNECTION DETAIL

N.T.S.

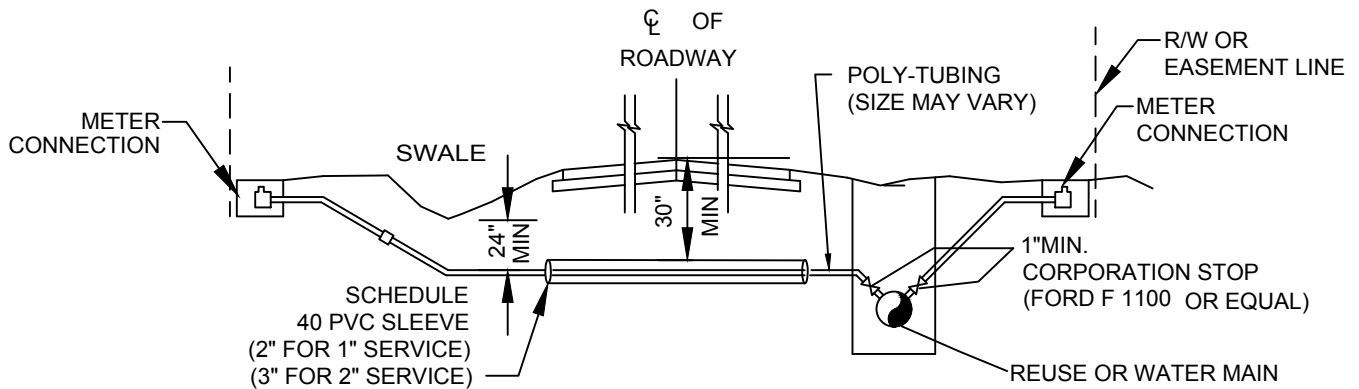

- 1.) TAPS SHALL NOT BE CLOSER THAN TWO FEET APART OR WITHIN TWO FEET OF ANY JOINT.
- 2.) TAPS IN MULTIPLE GROUPS SHALL NOT BE MADE IN THE SAME LONGITUDINAL LINE OF THE PIPE BUT MUST BE STAGGERED VERTICALLY.
- 3.) TAPPING SADDLE SHALL BE EPOXY COATED, DUCTILE IRON BODY WITH STAINLESS STEEL BAND(S) AND HARDWARE.
- 4.) BRASS FITTINGS AND BALL VALVES SHALL BE FORD F1100 OR EQUAL.
- 5.) ALL SERVICES SHALL HAVE COPPER TRACING WIRE.
- 6.) ALL SLEEVE ENDS SHALL BE SEALED WITH FOAM SEAL.
- 7.) INSERT STIFFENERS WILL NOT BE ACCEPTABLE.
- 8.) ALL WATERWORKS BRASS MUST BE LEAD FREE.
- 9.) METER SIZE AND SERVICE LINE PIPING DOWNSTREAM OF METER SHALL BE MINIMALLY SIZED BASED ON FIXTURE CALCS AS DETERMINED BY THE EOR.
- 10.) FOR CURBED ROADWAYS: CURB SHALL BE ETCHED WITH THE LETTER "W" FOR WATER SERVICE AND "R" FOR REUSE SERVICE DIRECTLY PERPENDICULAR TO THE METER.

WATER & REUSE SERVICE CONNECTION

N.T.S.



CITY OF VENICE
ENGINEERING DEPARTMENT

401 WEST VENICE AVE.
VENICE FL 34285
(941) 486-2626
FAX (941) 480-3031

UTILITIES - WATER

**RESIDENTIAL METER &
SERVICE CONNECTION**

DATE
JAN. 2018

SHEET NO.
W-8

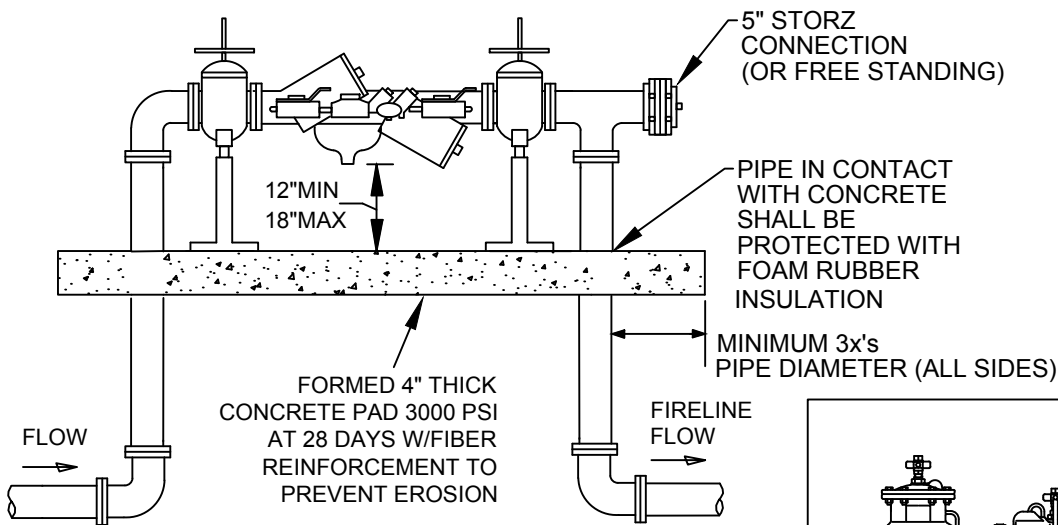

STANDARD ORIENTATION

OPTIONAL ORIENTATIONS:

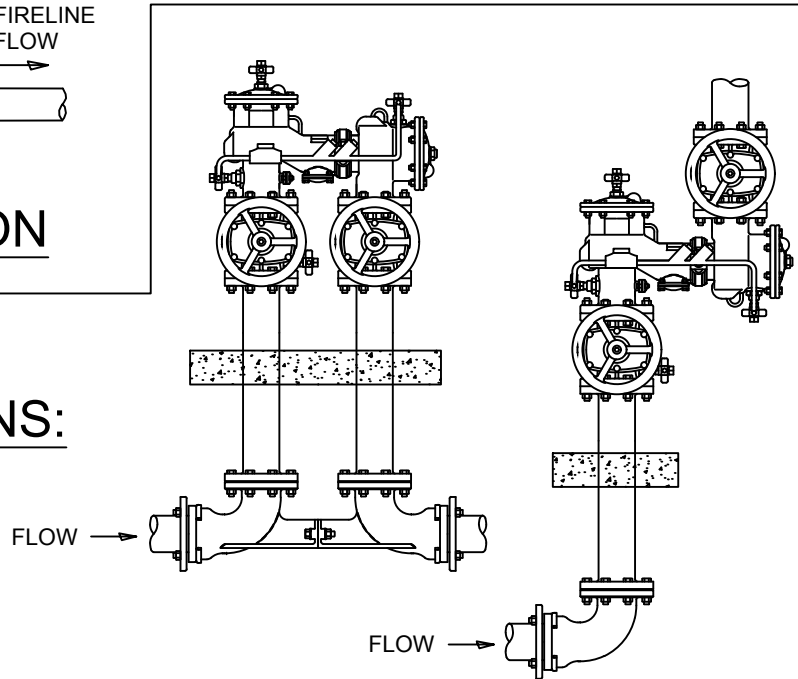

- 1.) ALL BACKFLOW PREVENTION ASSEMBLIES SHALL BE APPROVED BY THE UNIVERSITY OF SOUTHERN CALIFORNIA FOUNDATION FOR CROSS-CONNECTION CONTROL AND HYDRAULIC RESEARCH AND/OR 1047 OR 1048 ASSE AS APPLICABLE
- 2.) 45° FITTINGS MAY BE SUBSTITUTED FOR 90° FITTINGS.
- 3.) PIPE BETWEEN TAP & ISOLATION VALVE SHALL BE C900 PVC OR HDPE.
- 4.) IF TEEING OFF FOR POTABLE SERVICE, INSTALL INDICATOR VALVE BETWEEN TEE FOR POTABLE SERVICE AND FIRE SERVICE BACKFLOW ASSEMBLY.
- 5.) ASSEMBLY SHALL BE PAINTED RED WITH ALKYD ENAMEL, EPOXY OR POLYURETHANE BASED PAINT, EXCEPT FOR STAINLESS STEEL PARTS.
- 6.) VALVE ASSEMBLIES SHALL MEET NFPA 24 REQUIREMENTS AND INDICATOR VALVES SHALL BE PROVIDED.
- 7.) FOR CLEARANCE ISSUES, PLEASE REFER TO THE CURRENT FLORIDA FIRE PREVENTION CODE REQUIREMENTS.
- 8.) FOR FIRE PROTECTION SYSTEMS EQUIPPED WITH A FIRE PUMP, THE PIPE BETWEEN THE CHECK VALVE AND THE OUTSIDE CONNECTION SHALL BE EQUIPPED WITH AN APPROVED BALL DRIP.
- 9.) BACKFLOW PREVENTION ASSEMBLY TYPE SHALL BE DETERMINED BY THE CITY OF VENICE UTILITIES DEPARTMENT'S MOST CURRENT CROSS-CONNECTION CONTROL PROGRAM.
- 10.) 5" STORZ INLET CONNECTION MAY BE REDUCED FOR PIPE SIZES LESS THAN 5".

FIRE SERVICE BACKFLOW ASSEMBLY

SIZE 2" - 10"

N.T.S.



CITY OF VENICE
ENGINEERING DEPARTMENT

401 WEST VENICE AVE.
VENICE FL 34285
(941) 486-2626
FAX (941) 480-3031

UTILITIES - WATER

**FIRE SERVICE
BACKFLOW ASSEMBLY**

DATE
JAN. 2018

SHEET NO.
W-9

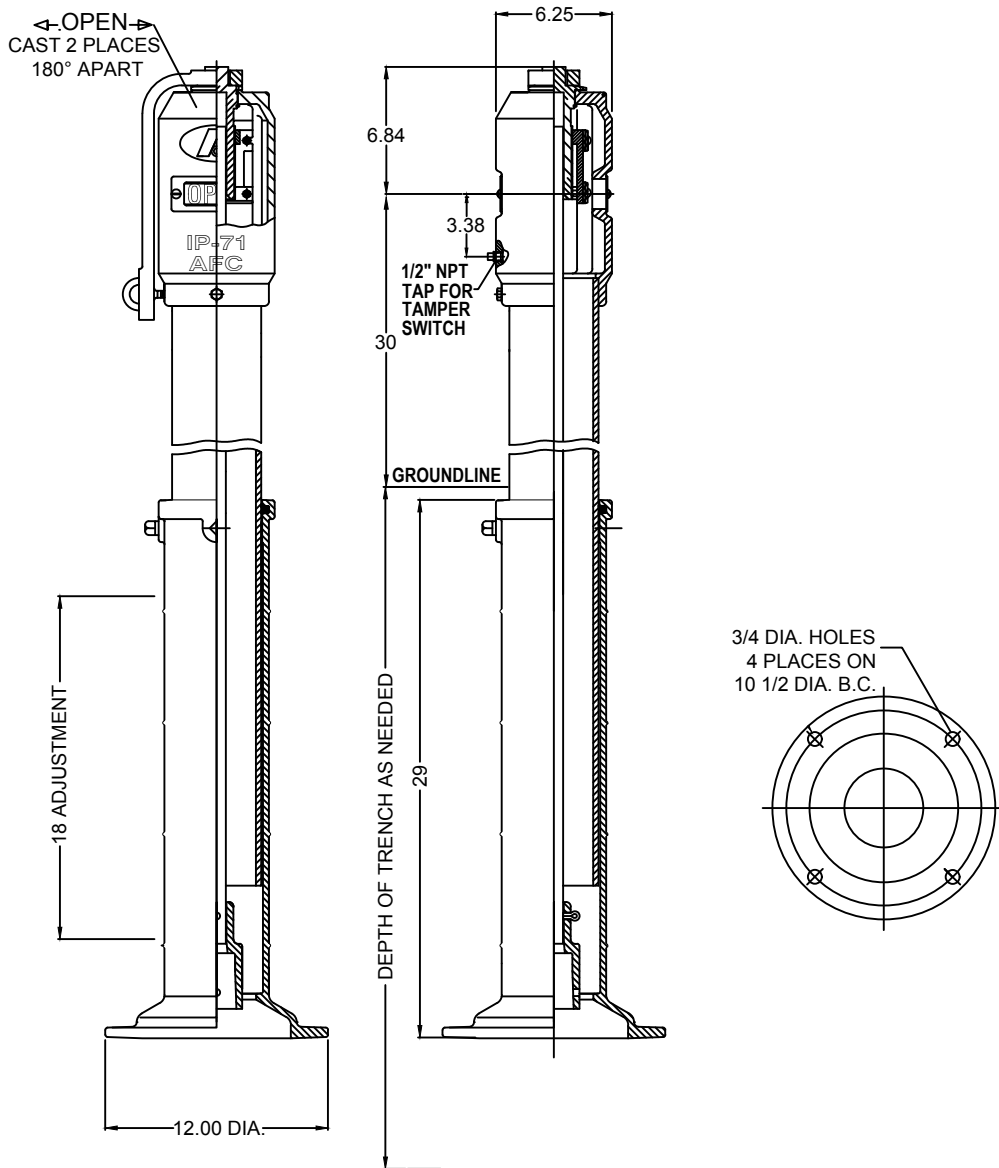

- 1) INDICATOR POST REQUIRED WHEN FIRE SERVICE POINT OF CONNECTION IS ON A POTABLE WATER SERVICE.
- 2) INSTALL INDICATOR POST AND VALVE BETWEEN TEE FOR POTABLE SERVICE AND FIRE SERVICE BACKFLOW ASSEMBLY.
- 3.) AMERICAN FLOW CONTROL IP-71 INDICATOR POST OR EQUIVALENT SHALL BE INSTALLED.
- 4.) UNDERWRITERS LABORATORIES LISTED AND FACTORY MUTUAL RESEARCH APPROVED.
- 5.) FOR USE WITH VALVES WITH O-RING STEM SEALS.
- 6.) ALL EXPOSED EXTERIOR SURFACES COATED WITH TNE MEC 140 EPOXY AND TOP COATED WITH "RED" ENAMEL PER MANUFACTURER'S STANDARD PAINT.

FIRE SERVICE VALVE INDICATOR POST

N.T.S.

 <p>Venice, Florida "City on the Gulf"</p>	<p>CITY OF VENICE ENGINEERING DEPARTMENT</p> <p>401 WEST VENICE AVE. VENICE FL 34285 (941) 486-2626 FAX (941) 480-3031</p>	<p>UTILITIES - WATER</p> <hr/> <p>FIRE SERVICE INDICATOR POST</p>	<p>DATE JAN. 2018</p> <hr/> <p>SHEET NO. W-10</p>

UTILITIES
SEWER DETAILS

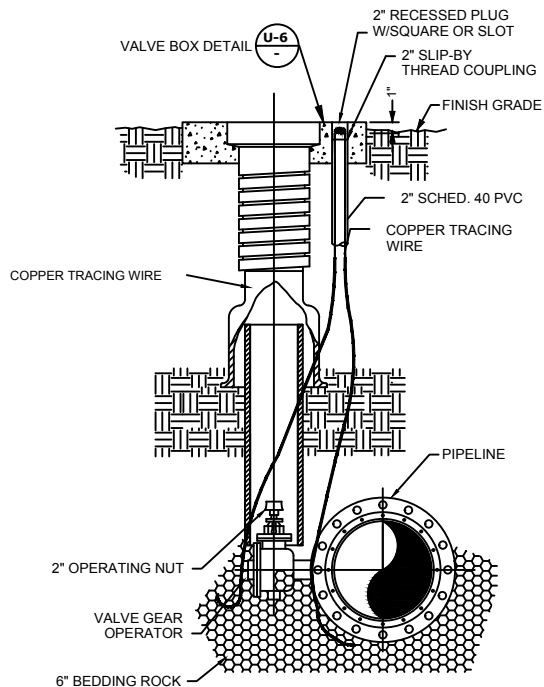

- 1.) PLUG VALVES SHALL BE MANUFACTURED BY DEZURIK.
- 2.) SEAT OF PLUG VALVE SHALL BE ON THE UPSTREAM SIDE OF THE BODY.
- 3.) VALVE SHALL BE INSTALLED IN CONFORMANCE WITH MANUFACTURES RECOMMENDATIONS.
- 4.) ALL SEWER FORCE MAIN PLUG VALVES SHALL BE GEAR OPERATED.

PLUG VALVE DETAIL

(SEWER FORCE MAINS ONLY)
N.T.S.

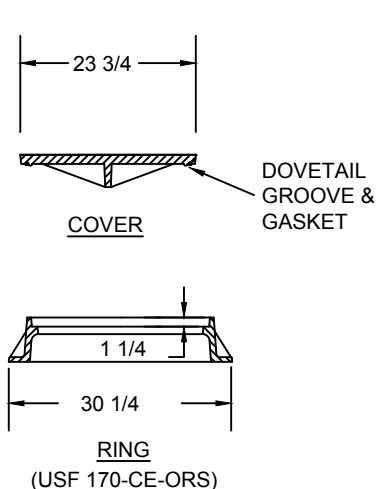

- 1.) MATERIAL: ASTM-A48 CLASS 30B GRAY IRON
- 2.) RING WT: 155 LBS. APP.
- 3.) COVER WT: 150 LBS. APP.

TYPICAL COVER

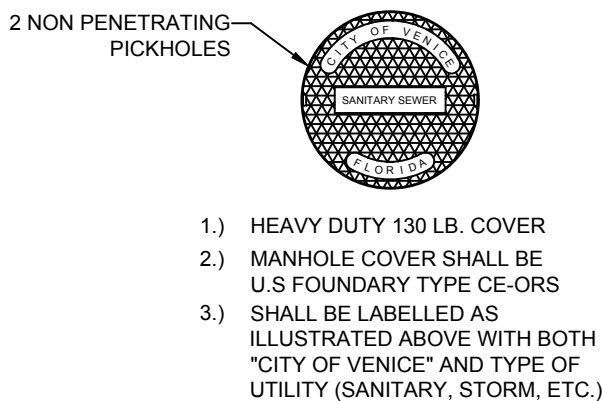

- 1.) HEAVY DUTY 130 LB. COVER
- 2.) MANHOLE COVER SHALL BE U.S. FOUNDARY TYPE CE-ORS
- 3.) SHALL BE LABELLED AS ILLUSTRATED ABOVE WITH BOTH "CITY OF VENICE" AND TYPE OF UTILITY (SANITARY, STORM, ETC.)

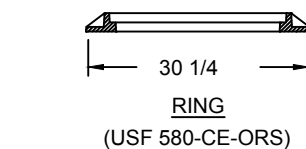

- 1.) MATERIAL: ASTM-A48 CLASS 30B GRAY IRON
- 2.) RING WT: 90 LBS. APP.
- 3.) COVER WT: 130 LBS. APP.

LOW PROFILE COVER

MANHOLE COVERS DETAIL

(ALL UNITS IN INCHES)

N.T.S.



CITY OF VENICE
ENGINEERING DEPARTMENT

401 WEST VENICE AVE.
VENICE FL 34285
(941) 486-2626
FAX (941) 480-3031

UTILITIES - SEWER

**PLUG VALVE &
MANHOLE COVERS**

DATE
JAN. 2018

SHEET NO.
S-1

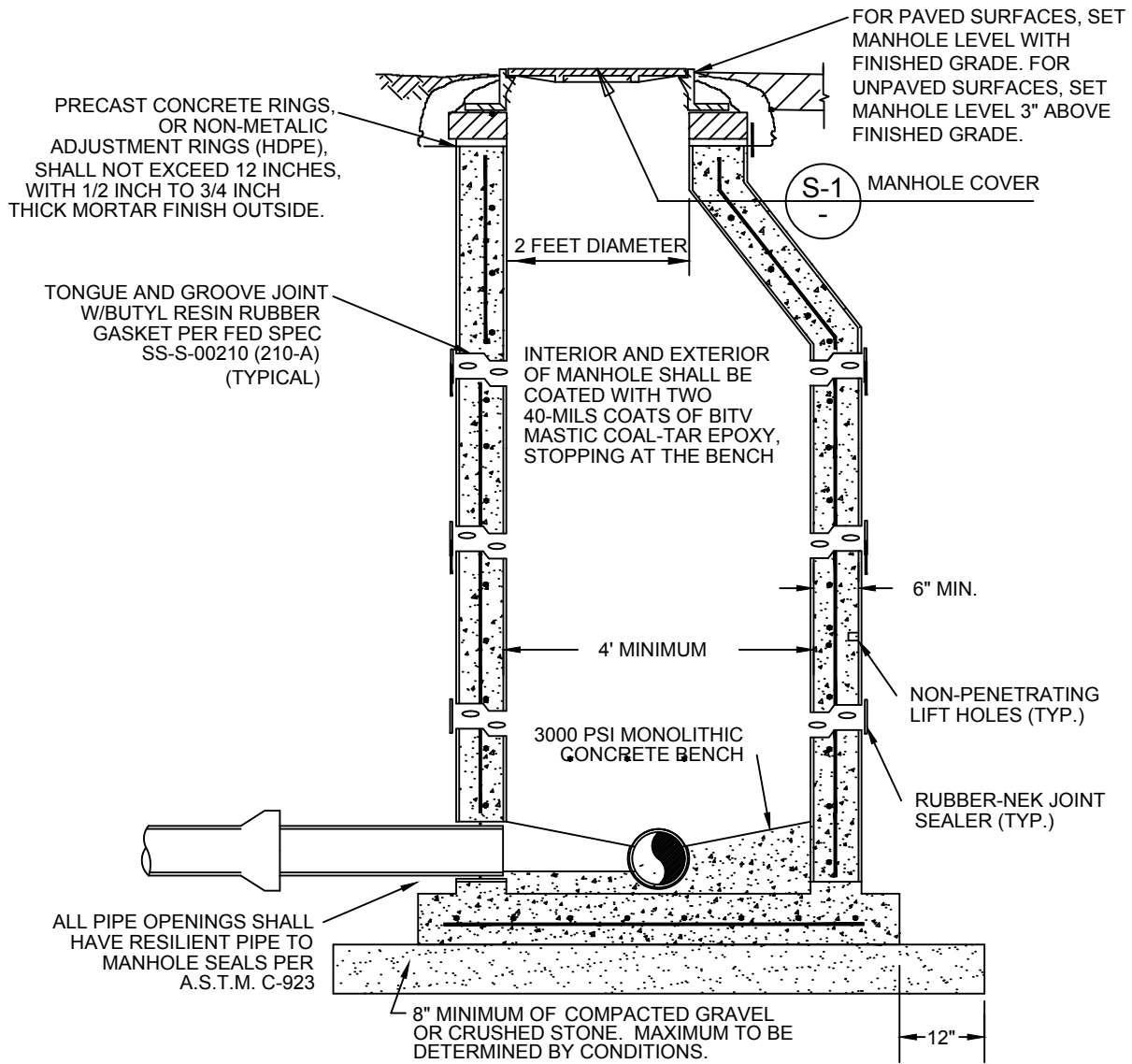

NOTES:

- 1.) MANHOLE SHALL CONFORM TO A.S.T.M. C-478 LATEST REVISION TYPE II CONCRETE, 4000 P.S.I. 28 DAY COMPRESSIVE STRENGTH
- 2.) TURBULENT MANHOLES, DROP MANHOLES, AND EXISTING MANHOLES RECEIVING FORCE MAINS SHALL BE LINED WITH AGRU SURE GRIP HDPE.
- 3.) ECCENTRIC CONE MANHOLES SHALL BE USED WHENEVER POSSIBLE. WHERE STRUCTURAL CONDITIONS DICTATE, A CONCENTRIC CONE MAY BE USED IN LIEU OF AN ECCENTRIC CONE.
- 4.) FOR MANHOLES LESS THAN 5 FEET IN DEPTH, A SHALLOW MANHOLE (DETAIL 8, THIS SHEET) SHALL BE USED.
- 5.) MONOLITHIC, DUCTILE IRON ADJUSTMENT RINGS MAY ONLY BE USED FOR SURFACE OVERLAY PROJECTS, NOT FOR NEW CONSTRUCTION.
- 6.) INFLOW DISH SHALL BE PROVIDED AND INSTALLED BY CONTRACTOR.

SANITARY SEWER MANHOLE DETAIL

N.T.S.



CITY OF VENICE
ENGINEERING DEPARTMENT

401 WEST VENICE AVE.
VENICE FL 34285
(941) 486-2626
FAX (941) 480-3031

UTILITIES - SEWER

**SANITARY SEWER
MANHOLE**

DATE
JAN. 2018

SHEET NO.
S-2

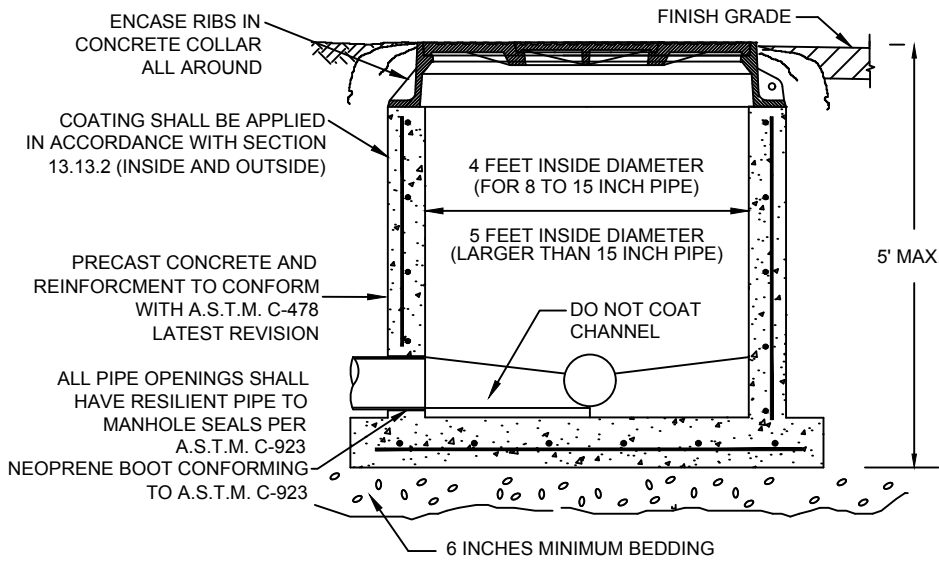

**SHALLOW MANHOLE
PROFILE**

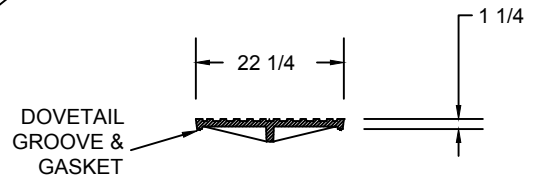

**ACCESS COVER
PROFILE**

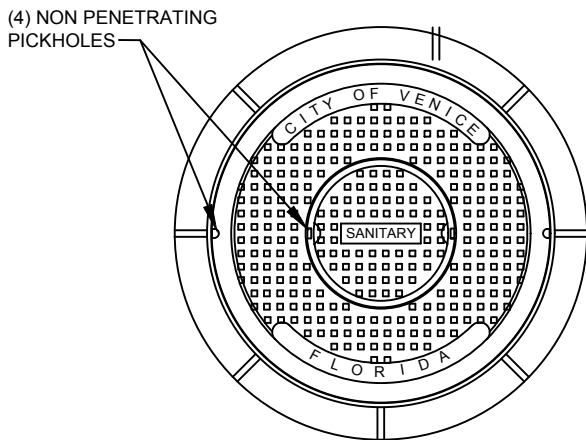

PLAN

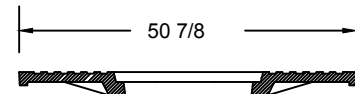

**COVER
PROFILE**

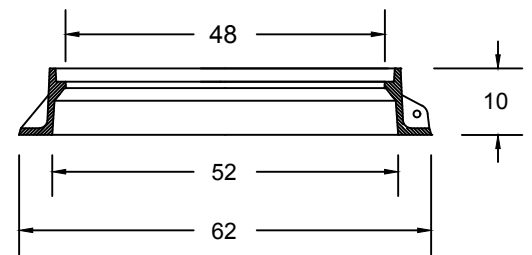

**RING
PROFILE**

- 1.) SHALLOW MANHOLE SHALL BE INSTALLED WHEREVER THE BASE OF THE MANHOLE IS LESS THAN 5 FEET BELOW THE FINISHED GRADE
- 2.) MANHOLE SHALL CONFORM TO A.S.T.M. C-478 LATEST REVISION TYPE II CONCRETE, 4000 P.S.I. 28 DAY COMPRESSIVE STRENGTH
- 3.) INTERCEPTOR MANHOLES, DROP MANHOLES, AND MANHOLES WITH INTERCEPTING FORCE MAINS SHALL BE LINED.
- 4.) ALL JOINTS SHALL BE WRAPPED WITH RUBBER-NEK SEALER.
- 5.) INFLOW DISH SHALL BE PROVIDED AND INSTALLED BY CONTRACTOR.
- 6.) COVER SPECIFICATIONS:
 MATERIAL: ASTM-A48 CLASS 30B GRAY IRON.
 RING WT: 700 LBS. APP. (USF 690-AG-M)
 OUTER COVER WT: 675 LBS. APP.
 INNER COVER WT: 105 LBS. APP.

PRECAST SHALLOW MANHOLE DETAIL

N.T.S.



CITY OF VENICE
ENGINEERING DEPARTMENT

401 WEST VENICE AVE.
VENICE FL 34285
(941) 486-2626
FAX (941) 480-3031

UTILITIES - SEWER

**PRECAST SHALLOW
MANHOLE**

DATE
JAN. 2018

SHEET NO.
S-3

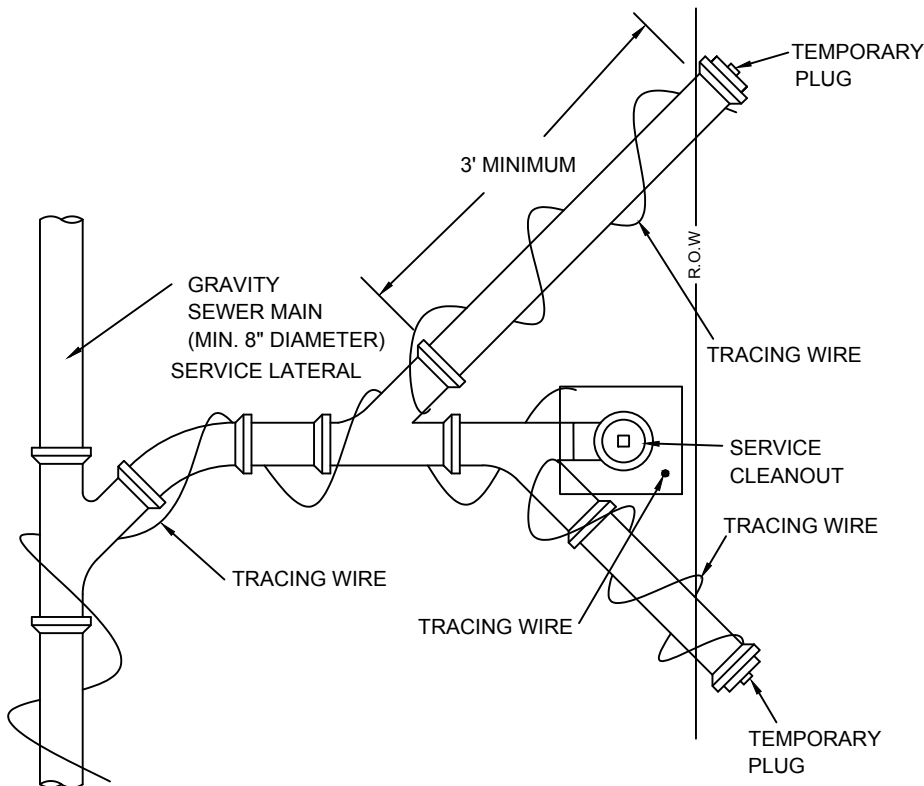

CLEANOUT PLAN

- 1.) ALL SERVICE LATERAL JOINTS SHALL BE GASKETED FROM MAIN WYE.
- 2.) ALL LATERAL SERVICES SHALL BE A MINIMUM OF SIX INCHES IN DIAMETER.
- 3.) A CLEANOUT SHALL BE PROVIDED AT THE RIGHT OF WAY OR THE PROPERTY LINE.
- 4.) COPPERHEAD TRACING WIRE #12 AWG OR EQUAL SHALL BE USED .IT SHALL BE COLOR CODED TO REFLECT WHAT THE PIPE CARRIES. (BLUE = WATER, GREEN = SEWER, PURPLE = REUSE)
- 5.) AIR TEST REQUIRED.
- 6.) THE BUILDING GENERAL CONTRACTOR SHALL INSURE THE APPLICABLE SERVICING SANITARY SEWER CLEANOUT CONNECTION IS PLACED AT FINISH GRADE WITH COVER, AND IS WITH A CONCRETE PAD AT THE TIME CERTIFICATION OF OCCUPATION (CO) IS REQUESTED. NON COMPLIANCE MAY RESULT IN A DELAY OF CO.
- 7.) FOR CURBED ROADWAYS: CURB SHALL BE ETCHED WITH THE LETTER "S" DIRECTLY PERPENDICULAR TO THE SEWER CLEAN-OUT.

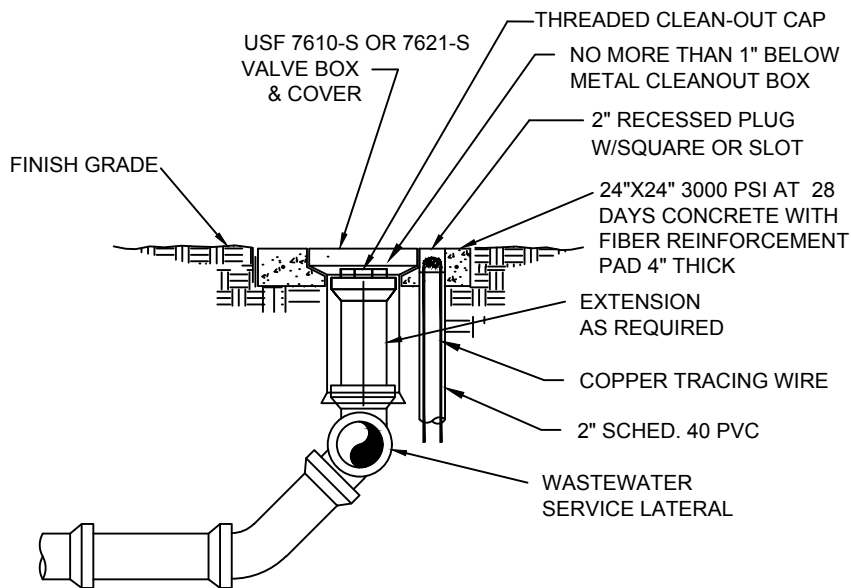

CLEANOUT PROFILE

SANITARY SEWER SERVICE & CLEANOUT DETAIL

N.T.S.



CITY OF VENICE
ENGINEERING DEPARTMENT

401 WEST VENICE AVE.
VENICE FL 34285
(941) 486-2626
FAX (941) 480-3031

UTILITIES - SEWER

SEWER SERVICE & CLEANOUT

DATE
JAN. 2018

SHEET NO.
S-4

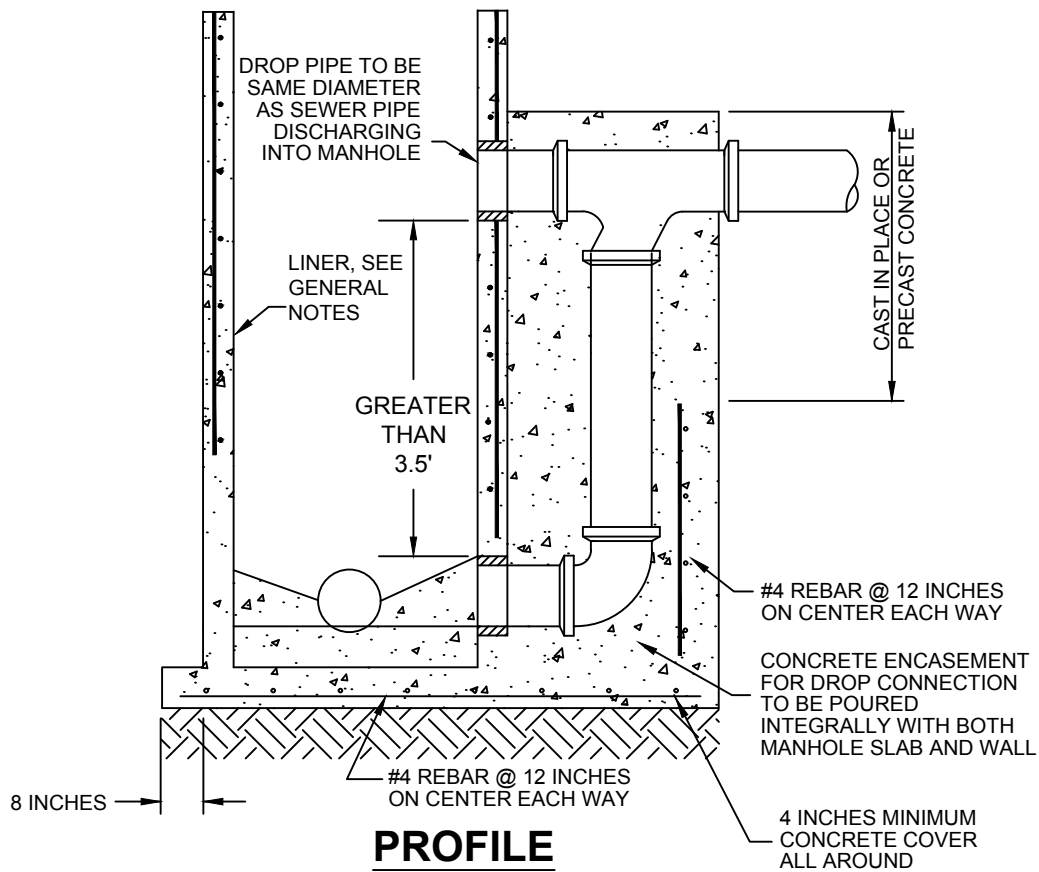

- 1.) MANHOLE SHALL CONFORM TO A.S.T.M. C-478 LATEST REVISION TYPE II CONCRETE, 4000 P.S.I. 28 DAY COMPRESSIVE STRENGTH
- 2.) THE NEW CONSTRUCTION OF INTERCEPTOR MANHOLES, DROP MANHOLES, AND MANHOLES INTERCEPTING FORCE MAINS SHALL BE LINED WITH AGRU SURE GRIP HDPE WITH A GU BASE LINER.
- 3.) DROP MANHOLES SHALL NOT BE USED WITHOUT WRITTEN PERMISSION FROM THE UTILITY DEPARTMENT.

SANITARY SEWER DROP MANHOLE

N.T.S.



CITY OF VENICE
ENGINEERING DEPARTMENT

401 WEST VENICE AVE.
VENICE FL 34285
(941) 486-2626
FAX (941) 480-3031

UTILITIES - SEWER

**SANITARY DROP
MANHOLE**

DATE
JAN. 2018

SHEET NO.
S-5

**UTILITIES
LIFT STATION
DETAILS**

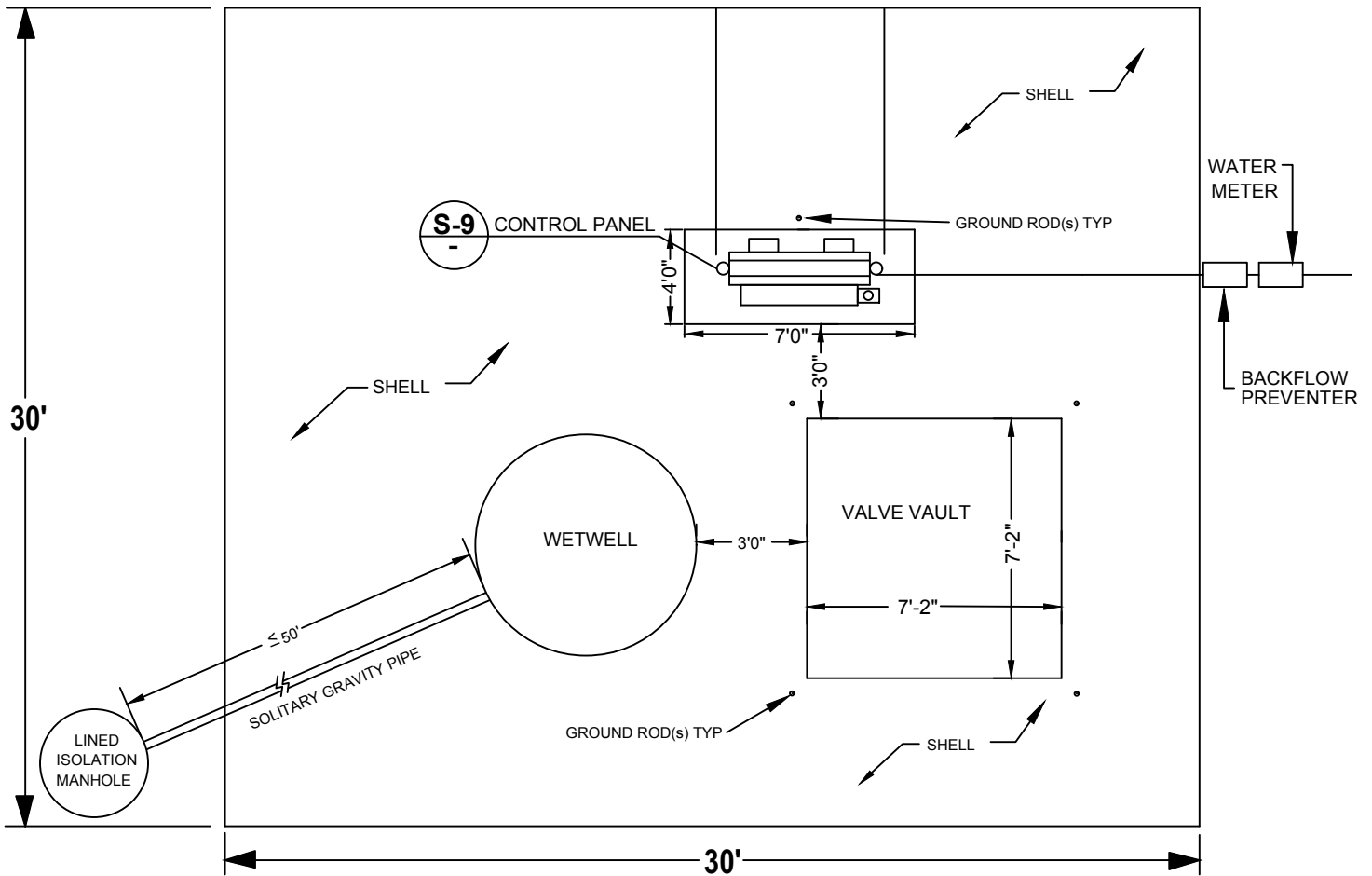

1. UTILITY OWNED LIFT STATIONS SHALL HAVE A MINIMUM DIMENSION OF THIRTY FEET (30') BY THIRTY FEET (30') WITHIN AN "EXCLUSIVE" EASEMENT GRANTED TO THE CITY OF VENICE.
2. THE ENGINEER OF RECORD MUST PROVIDE A LIFT STATION LAYOUT PLAN WHICH INCLUDES DIMENSIONS, EXISTING AND PROPOSED GRADES WHICH DEMONSTRATE POSITIVE DRAINAGE AWAY FROM THE LIFT STATION AND CALCULATIONS VERIFYING NO SITE FLOODING WILL OCCUR DURING THE 25YR, 24 HR STORM EVENT.
3. CONTRACTOR TO PLANT TREES AND SHRUBS SURROUNDING THE LIFT STATION WITH EXCEPTION OF A 12 FOOT ENTRANCE. THE LOCATION OF THE 12 FOOT ENTRANCE SHALL BE APPROVED BY THE UTILITIES DEPARTMENT. TREES & SHRUBS SHALL NOT INTERFERE WITH STRUCTURE, PANELS, ACCESS TO WETWELL OR VALVE VAULT. ALL TREES & SHRUBS SHOULD MATCH SURROUNDINGS SO AS TO MAKE THE LIFT STATION INCONSPICUOUS.
4. THE HOME OWNER ASSOCIATION OR ENTITY RESPONSIBLE FOR COMMON AREA MAINTENANCE IS RESPONSIBLE TO MAINTAIN THE TREES & SHRUBS PLANTED AT LIFT STATION.
5. FENCING MAY BE REQUIRED AT THE DISCRETION OF THE UTILITY DEPARTMENT WHEN IT IS DETERMINED THAT GENERAL PUBLIC SAFETY MAY BE AT RISK OR INCREASED VISUAL BUFFERING IS NECESSARY.
6. CONDUIT CORES IN WETWELL SHALL BE DIRECTED TOWARDS THE CONTROL PANEL TO MINIMIZE DEFLECTIONS.
7. ENTIRE LIFT STATION SITE SHALL BE LINED WITH 2 LAYERS OF VISQUEEN AND WASHED SHELL AT A MINIMUM OF 6" THICKNESS.
8. MINIMUM 12' WIDE ACCESS ROADWAY TO LIFT STATION MUST BE PROVIDED.
9. AN ADDITIONAL FOUR FOOT WALK-THRU GATE MAY BE REQUIRED.
10. F.P.L. POINT OF CONNECTION (P.O.C.) TO BE ADDED ON AS LOCATED TO L.S. METER CAN.
11. METER CAN TO L.S. P.O.C. LOCATE TO BE ADDED ON REFERENCE DRAWINGS.
12. ALL SPARE PARTS FROM THE SPARE PARTS LIST SHALL BE DELIVERED TO COV UTILITIES DEPARTMENT PRIOR TO ACCEPTANCE OF LIFT STATION.

LIFT STATION SITE LAYOUT

N.T.S.



CITY OF VENICE
ENGINEERING DEPARTMENT

401 WEST VENICE AVE.
VENICE FL 34285
(941) 486-2626
FAX (941) 480-3031

UTILITIES - LIFT STATION

**LIFT STATION
SITE LAYOUT**

DATE
JAN. 2018

SHEET NO.
LS-1

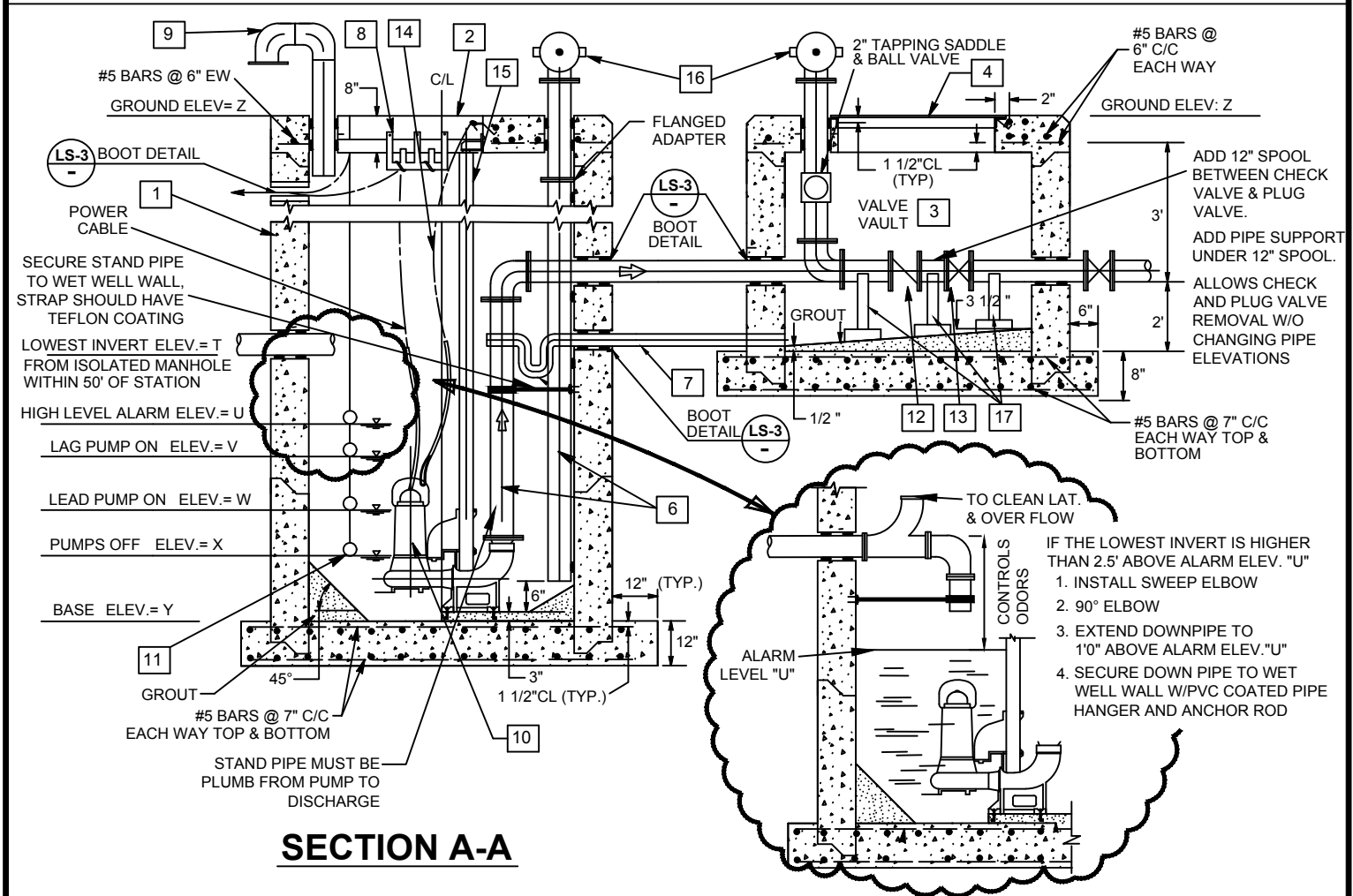
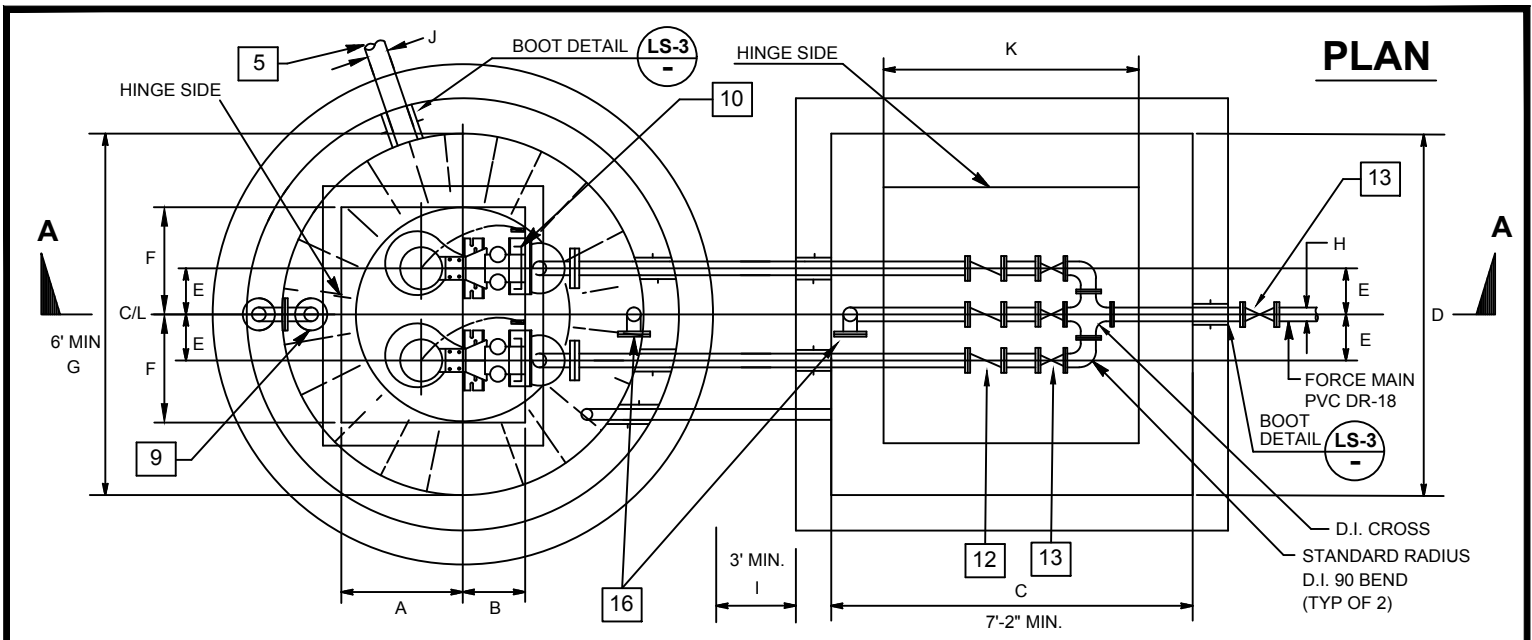

SANITARY SEWER LIFT STATION DETAIL

N.T.S.

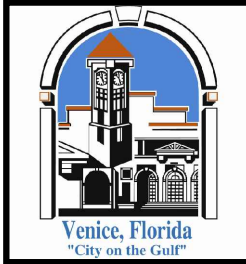

CITY OF VENICE
 ENGINEERING DEPARTMENT
 401 WEST VENICE AVE.
 VENICE FL 34285
 (941) 486-2626
 FAX (941) 480-3031

UTILITIES - LIFT STATION

LIFT STATION

DATE
 JAN. 2018

SHEET NO.
LS-2

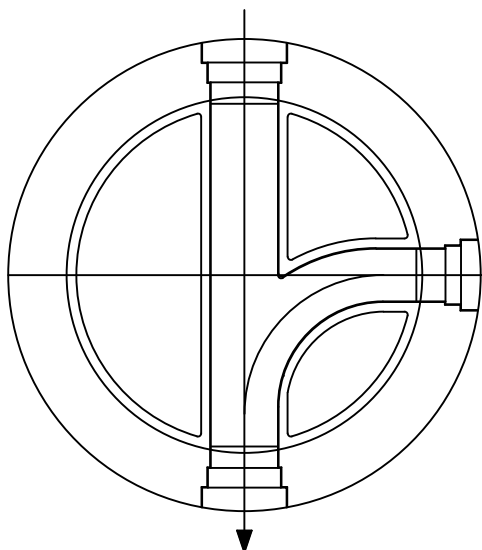

Brick masonry or Precast concrete grade rings @ 25" I.D. or Field poured concrete collar

N.T.S.

1. BENCHES SHALL BE FIBERGLASS REINFORCED PLASTIC.
2. BASE SHALL BE EXTENDED SKIRT TO FIRST JOINT, AS MANUFACTURED BY GU.
3. NO FIELD MODIFICATIONS TO THE MANHOLE SHALL BE ACCEPTED.
4. INFLOW DISH SHALL BE PROVIDED.

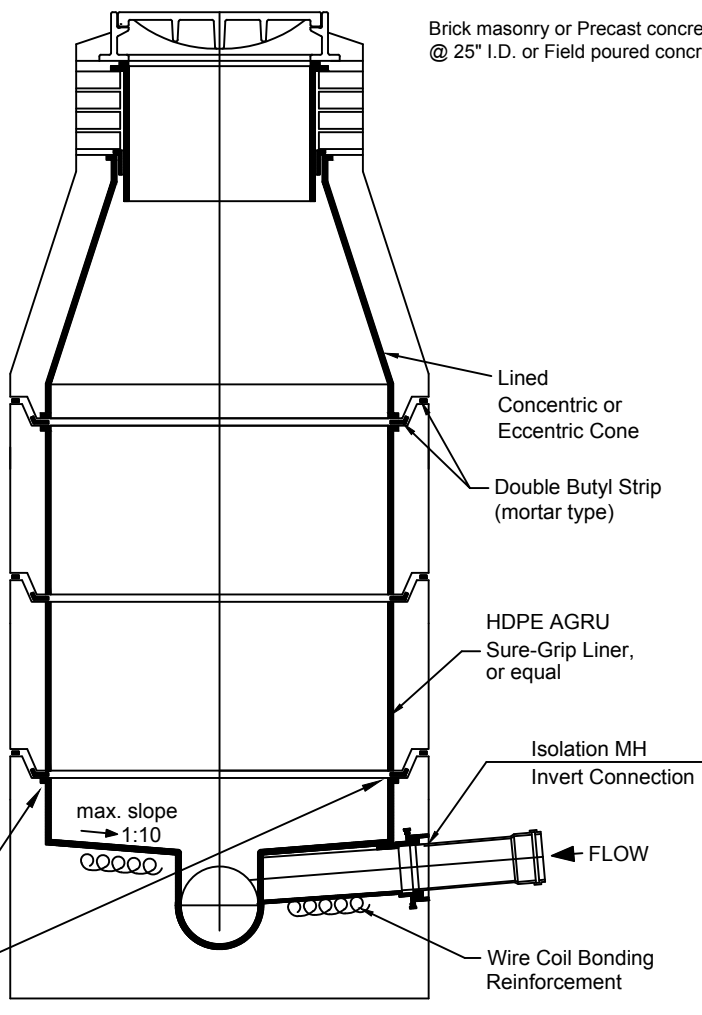

COMPLETELY LINED ISOLATION MANHOLE DETAIL

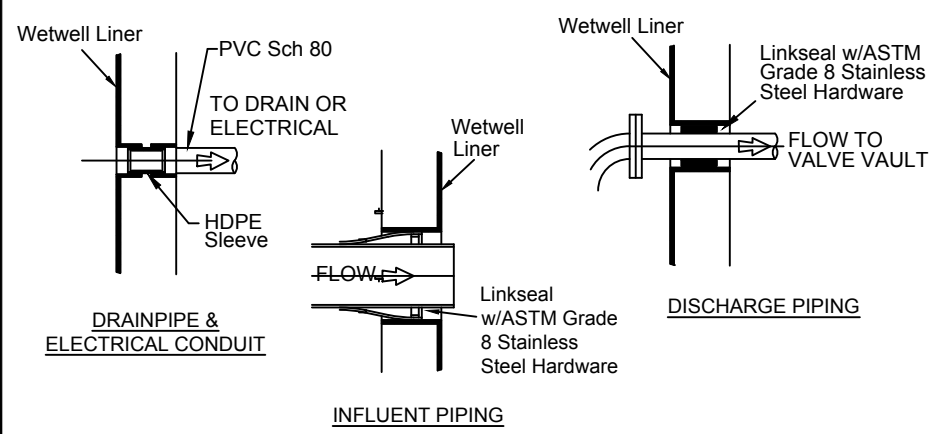

BOOT DETAILS

N.T.S.

A-LOCK BOOT OR COMPRESSION GASKET INSTALLATION INSTRUCTIONS

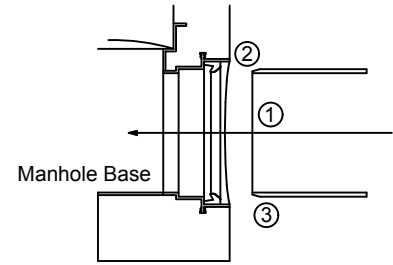

1. CLEAN BELL.
2. INSTALL GASKET AS SHOWN.
3. LUBRICATE SPIGOT AND SLIDE INTO BELL AND GASKET.

ISOLATION MH INVERT CONNECTION

N.T.S.



CITY OF VENICE
ENGINEERING DEPARTMENT

401 WEST VENICE AVE.
VENICE FL 34285
(941) 486-2626
FAX (941) 480-3031

UTILITIES - LIFT STATION

ISOLATION MANHOLE & BOOT DETAILS

DATE
JAN. 2018

SHEET NO.
LS-3

Item	Quantity	Description
1	1	WETWELL: Shall be reinforced pre-cast concrete as specified by ASTM C-478, latest revision. Minimum 6-ft. interior diameter. Joints shall be sealed with Butyl seal conforming to federal specification SS-S-00210. Interior shall be lined with HDPE Agru Sure-Grip and welded by an Agru certified welder, or equal. Exterior shall be coated with coal-tar based sealant as manufactured by Concrete Sealants, New Carlisle, Ohio or equal, including the bottom of the slab. All exterior joints shall be wrapped with rubberneck tape. Wetwell shall be set on a minimum base of 6 inches of gravel. A minimum of three 2-inch PVC conduits shall be provided for electrical connections to the motor control panel. All hardware supplied shall be 316 SS. No wetwell shall constructed with a depth greater than 25 ft.
2	1	WETWELL ACCESS HATCH COVER: 2 door access as manufactured by Halliday Products or equal. Access frame and covers shall be fabricated of 1/4 inch aluminum diamond- pattern plate, withstand a minimum live load of 150 psf, and provide support for 316 SS guide rails and 316 SS cable holder for electrical wiring. Covers shall provide lifting handle and safety latch to hold cover in open position. Locking hasps shall be furnished for each cover.
3	1	VALVE VAULT: Shall be pre-cast concrete. All piping shall have 12 inch clearance to floor and walls. Interior and exterior shall be coated with two coats of Koppers Intersol 49 or equal. Install 2 inch 316 SS saddle clamp & ball valve on vertical riser by-pass piping inside of valve vault. All piping entering or exiting the valve vault shall have a rubber boot.
4	1	VALVE VAULT COVER: Shall have a 2-door access as manufactured by Halliday Products or equal. Access frame and covers shall be fabricated of 1/4 inch aluminum diamond-pattern plate and withstand a minimum live load of 150 psf. Each cover shall provide a lifting handle and safety latch to hold cover in open position. Locking hasps shall be furnished for each cover. All hardware supplied shall be 316 SS.
5	1	ISOLATION MANHOLE AND INFLUENT PIPING: Isolation manhole shall be located within fifty (50) feet of the wetwell and discharge through a solitary gravity pipe directly into the wetwell. The isolation manhole walls shall be lined with Agru Sure-Grip; while the manhole invert and bottom shall be lined with a GU/FRP liner or equal. All Interior Seams/Joints to be welded by an Agru certified welder. Isolation manhole shall be located outside of traffic area.
6	1	PIPING: All piping within the wetwell (discharge, standpipe, and vent) shall be solvent-weld Schedule 80 PVC with a minimum diameter of four inches, except for the ductile iron spool leading outside the wetwell to the cam-lock. All piping and fittings in the valve vault shall be flanged ductile iron and coated with 2 coats coal-tar epoxy.
7	1	VALVE VAULT DRAIN: 2-inch PVC drain with trap. Locate trap to inside of wet well.
8	1	FLOAT CABLE RACK: 316 Stainless Steel (Do NOT install on wall w/invert)
9	1	VENT PIPE: 4-inch Solvent-weld Schedule 80 PVC pipe with stainless steel screen.
10	2	PUMPS: Shall be 240v 3-phase power, submersible-type Hydromatic or ABS, no equal. Pumps shall be a minimum of 100gpm. No vortex or grinder pumps are allowed. A pump curve shall be attached to this set of plans including points of operation or design conditions. Each pump power cable shall have a separate conduit exiting the wetwell and a single additional 2-inch conduit shall be provided for the float control cables. (1 spare pump, same as specs. 1 spare impeller & wear ring for each pump). Impellers shall be 316 stainless steel.
11	4	FLOAT LEVEL SWITCHES: Manufacturer - Anchor Scientific Inc. normally open types control duty float switch Single Throw - Double Pole(STDP) 10 amp @ 120 Vac narrow angle mercury switch Model - S50NO-EZC (Spare set of floats). Do not install on wall with invert.
12	3	CHECK VALVES: Use only valves manufactured by Mueller. Valves shall be iron body, bronze-mounted, stainless steel hinge pin, outside lever and weight-operated, swing non-slam type, and equipped with removable inspection covers. Units shall be rated for 150 psi minimum working pressure and shall permit full flow area equal to that of the connecting pipe. All check valves shall have a petcock tapped into the top of the bonnet providing a 1/4-inch NST, female fitting for attachment of a pressure gauge.
13	4	PLUG VALVES: Valves shall be DeZurik. Bodies shall be cast iron per ASTM A 126, Class B. Ends shall be flanged, Class 125 per ANSI B16.1. Plugs shall be cast iron (ASTM A 126, Class B), or ductile iron (ASTM A 536, Grade 65- 45-12) with neoprene facing. Valve body seats shall be 316 stainless steel or have a raised welded-in overlay at least 1/8-inch thick of not less than 90% nickel. Body capscrews and bolts and nuts shall be Type 316 stainless steel. Packing shall be butadiene-filled Teflon and replaceable with valve body under full pressure. Plug valves, 4 inches through 12 inches, shall be non-lubricated type. Minimum pressure rating shall be 175 psi.
14	2	LIFT CABLE: 316 Stainless Steel installed on each pump.
15	1	GUIDE RAILS: 2-inch diameter rails, 316 Stainless Steel, shall be installed plumb from top to bottom, max. 12" from top of lid.
16	1	CAM-LOCK: Ductile iron spool piping with quick disconnect, dust cover, and chain. Position towards by-pass pump access.
17	AS NEEDED	PIPE SUPPORT: Adjustable iron pipe support stands in valve vault, minimum seven (7) and shall be coated with 2 coats of coal-tar epoxy. All above ground by-pass piping to be lined epoxy coated ductile iron.

- 1.) METER FEES MUST BE PAID IN FULL PRIOR TO THE LIFT STATION START-UP.
- 2.) ENGINEER MUST PROVIDE A LIFT STATION SITE PLAN WHICH INCLUDES EXISTING AND PROPOSED GRADES, SHOWING POSITIVE DRAINAGE AWAY FROM THE LIFT STATION.
- 3.) IF FORCE MAIN DISCHARGES INTO A MANIFOLDED SYSTEM, COORDINATE WITH THE CITY OF VENICE UTILITIES DEPARTMENT TO HAVE ONE PUMP OPERATING AT EACH MANIFOLDED LIFT STATION DURING TIME OF PUMP TESTING.
- 4.) CHECK CAPACITY OF PUMPS BY READING MOTOR AMP DRAW AND VOLTAGE WITH DISCHARGE PRESSURE AND RATE OF FLOW AT THREE POINTS ON THE PUMP CURVE. RATE OF FLOW AND HEAD MUST BE WITHIN RESPECTIVELY 10 PERCENT AND 5 PERCENT ABOVE APPROVED CURVE FOR ACCEPTANCE.
- 5.) FLOAT CONTROLS SHALL BE SUBMERSED TO CHECK AUTOMATIC OPERATION.
- 6.) ALL CONTROL PANEL ELEMENTS SHALL BE OPERATED DURING PUMP TESTING.
- 7.) THE PUMP AND CONTROL PANEL MANUFACTURER'S REPRESENTATIVES SHALL BE PRESENT FOR THE INITIAL START-UP AND TESTING AND SHALL SUBMIT A WRITTEN REPORT OF ACCEPTANCE TO THE CITY OF VENICE UTILITIES DEPARTMENT UPON SUCCESSFUL TEST RESULTS.
- 8.) SHOP DRAWINGS OF ENTIRE LIFT STATION INSTALLATION MUST BE APPROVED BY THE CITY OF VENICE ENGINEERING AND UTILITY DEPARTMENTS PRIOR TO PLACEMENT OF ORDER.

LIFT STATION SCHEDULE AND NOTES



CITY OF VENICE
ENGINEERING DEPARTMENT

401 WEST VENICE AVE.
VENICE FL 34285
(941) 486-2626
FAX (941) 480-3031

UTILITIES - LIFT STATION

**LIFT STATION
SCHEDULE**

DATE
JAN. 2018

SHEET NO.
LS-4

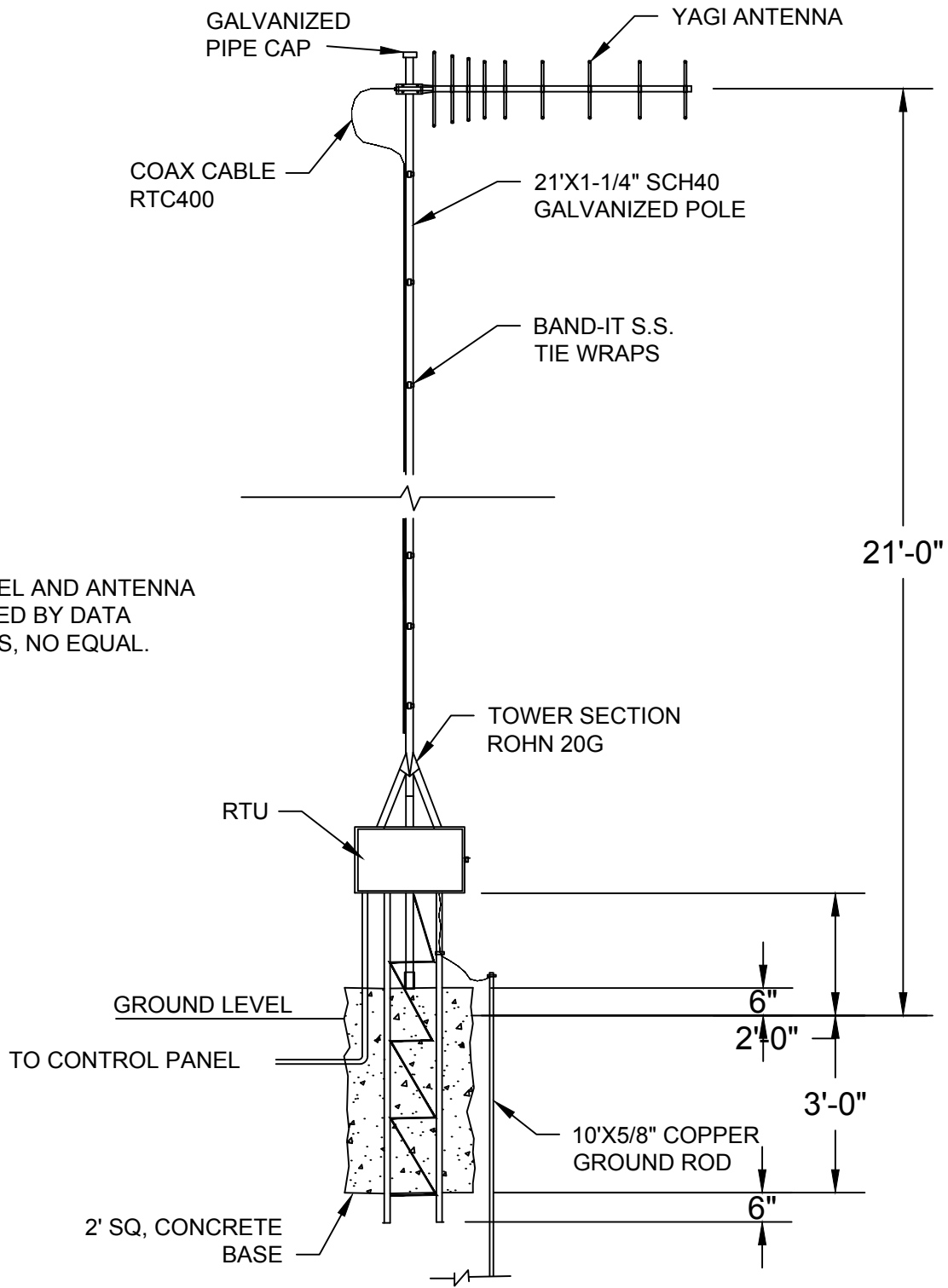

NOTE:

CONTROL PANEL AND ANTENNA
TO BE SUPPLIED BY DATA
FLOW SYSTEMS, NO EQUAL.

TELEMETRY CONTROL PANEL & ANTENNA

N.T.S.



CITY OF VENICE
ENGINEERING DEPARTMENT

401 WEST VENICE AVE.
VENICE FL 34285
(941) 486-2626
FAX (941) 480-3031

UTILITIES - LIFT STATION

LIFT STATION
TELEMETRY

DATE
JAN. 2018

SHEET NO.
LS-5

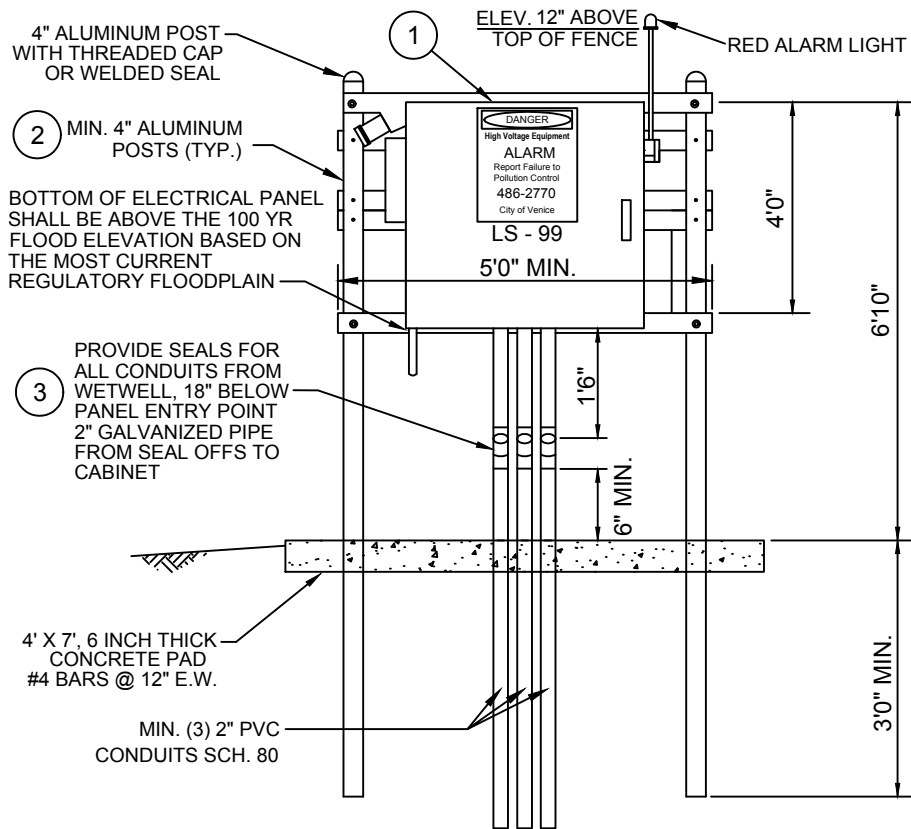

NOTES:

1. ALL MOUNTING HARDWARE SHALL BE MINIMUM OF 304 STAINLESS STEEL W/ NEOPRENE GASKETS.
2. ALL WATER SERVICE PIPING SHALL BE 3/4" RIGID COPPER.
3. ALL PIPING IN CONTACT WITH CONCRETE PAD SHALL BE COATED WITH COAL-TAR EPOXY.

ITEM	QUANTITY	DESCRIPTION
1	1	<p>CONTROL PANEL: LOCATION OF THE CONTROL PANEL SHALL CONFORM WITH THE LAYOUT AND ORIENTATION SHOWN WITHIN THIS PLAN SET AND THE CONTROL PANEL SHALL PROVIDE:</p> <ol style="list-style-type: none"> 1. TWO (2) MECHANICALLY INTERLOCKED MAIN CIRCUIT BREAKERS (ONE FOR NORMAL POWER, ONE FOR EMERGENCY POWER) SQUARE D TYPE QOU FOR CURRENTS UP TO 100 AMPERES AND TYPE KAL OVER 100 AMPERES. 2. EMERGENCY GENERATOR RECEPTACLE (CONFORM TO OTHERS IN SYSTEMS), COMBINATION STARTERS WITH CIRCUIT BREAKERS FOR EACH MOTOR, PLUG-IN ALTERNATOR AND ALTERNATOR TEST SWITCH, CONERY FLOAT CONTROLLERS (LAG PUMP(S) ON AT HIGH WATER LEVEL), HIGH LEVEL ALARM WITH LIGHT, HORN, AND SILENCER SWITCH, CONVENIENCE OUTLET WITH CIRCUIT BREAKER, LIGHTNING ARRESTOR, VOLTAGE/PHASE MONITOR, CONTROL CIRCUIT BREAKER, CONTROL TRANSFORMER (460-VOLT SERVICE ONLY). ALL DEVICES WILL BE LABELED WITH PLACARDS ATTACHED TO DEAD-FRONT DOOR. 3. ALUMINUM DEAD FRONT PANEL CONSTRUCTION, NEMA 4X TYPE 304 STAINLESS STEEL RAIN-TIGHT ENCLOSURE WITH DRIP SHIELD, SEAL FAIL MODULE, ELAPSED TIME METER, HOA SWITCH AND RUNNING LIGHTS FOR EACH PUMP. ALL MACHINE SCREWS WILL BE SCREWED INTO PRE-TAPPED THREADS IN THE BACK PANEL; SELF-TAPPING SCREWS OR NUT-SECURED SCREWS ARE UNACCEPTABLE. 4. ALL CONDUITS SHALL BE 2-INCH SCHEDULE 80 PVC, EXCEPT FOR THE GROUND CONDUIT, WHICH SHALL BE 1/2-INCH SCHEDULE 80 PVC. ALL CONDUITS SHALL ENTER FROM THE BOTTOM OF THE ENCLOSURES, WITH THE POWER SUPPLY CONDUITS BETWEEN SEAL OFF & PANEL SHALL BE 2" DIA.x18" LONG GALVANIZED PIPE. 5. LEVEL CONTROL SYSTEM TO START AND STOP THE PUMPS IN RESPONSE TO WETWELL LIQUID LEVELS. LEAD PUMP ON, LAG PUMP ON, PUMPS OFF, ALARM LEVELS SHALL BE SENSED BY ANCHOR SCIENTIFIC S50NO-EZC ROTOFLOATS SET AT ELEVATIONS WITHIN THE LIMITS DETAILED IN PAGE LS-5. 6. ALARM HORN AND GENERATOR RECEPTACLE WITH WEATHERPROOF FITTINGS WITH APPLIED SILICON AROUND PERIMETER OF MOUNTING. THE VISUAL ALARM LIGHT WILL BE MOUNTED WITH A WEATHERPROOF FITTING INTO THE TOP OF ALARM HORN USING 3/4-INCH SS OR ALUMINUM RIGID CONDUIT. THE CONDUIT WILL BE STRAPPED WITH A SS BRACKET WELDED TO THE SIDE OF THE CONTROL PANEL.
2	1	<p>CONTROL PANEL SUPPORT: ALL EQUIPMENT SHALL BE MOUNTED USING 4"x2" ALUMINUM CHANNEL. ISOLATE ALL DISSIMILAR METALS WITH 1/8" NON-METALLIC INSULTING WASHERS. 316 STAINLESS STEEL OR ALUMINUM MOUNTING HARDWARE THROUGHOUT.</p>
3	(AS NEEDED)	<p>ELECTRICAL CONDUIT: EACH PUMP POWER CORD AND LOW VOLTAGE SENSOR WILL HAVE A 2-INCH SCHEDULE 80 PVC ELECTRICAL CONDUIT WITH A 2-INCH APPLETON SEAL- OFF 18 INCHES BELOW THE BOTTOM OF THE ENCLOSURE. THE FOUR FLOAT SENSOR CABLES SHALL EACH BE FED THROUGH A 2-INCH SCHEDULE 80 PVC ELECTRICAL CONDUIT WITH A 2-INCH APPLETON SEAL-OFF 18 INCHES BELOW THE BOTTOM OF THE ENCLOSURE, AND SEAL OFF CEMENT W/ DUCT SEAL ON BOTTOM FROM ALL CONDUITS COMING FROM WETWELL.</p>

LIFT STATION CONTROL PANEL FRONT

N.T.S.



CITY OF VENICE
ENGINEERING DEPARTMENT

401 WEST VENICE AVE.
VENICE FL 34285
(941) 486-2626
FAX (941) 480-3031

UTILITIES - LIFT STATION

**CONTROL
PANEL FRONT**

DATE
JAN. 2018

SHEET NO.
LS-6

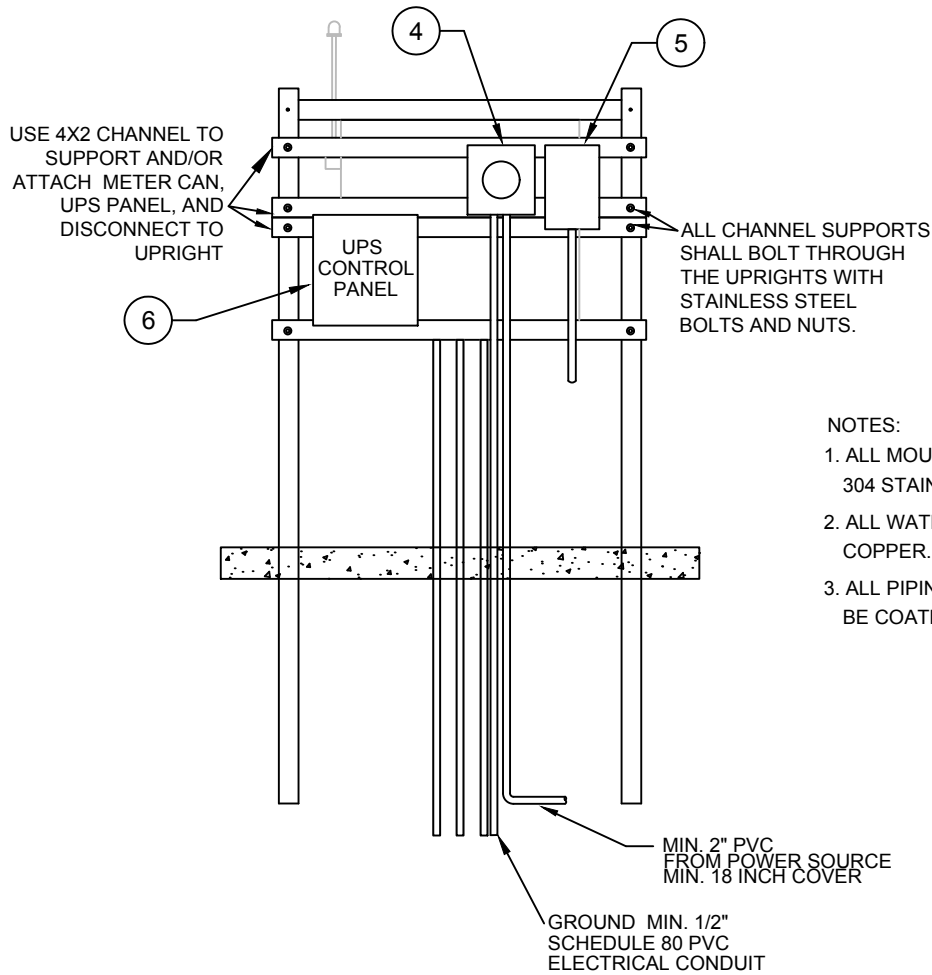

NOTES:

1. ALL MOUNTING HARDWARE SHALL BE MINIMUM OF 304 STAINLESS STEEL W/ NEOPRENE GASKETS.
2. ALL WATER SERVICE PIPING SHALL BE 3/4" RIGID COPPER.
3. ALL PIPING IN CONTACT WITH CONCRETE PAD SHALL BE COATED WITH COAL-TAR EPOXY.

ITEM	QUANTITY	DESCRIPTION
4	1	METER CAN: 200-AMP MILBANK METER CAN WITH BYPASS HANDLE. METER CAN WILL FEED 240 VOLT, 3-PHASE POWER WITH NEUTRAL.
5	1	DISCONNECT SWITCH: SHALL BE NEMA 4X TYPE 304 STAINLESS STEEL, NON-FUSED DISCONNECT SWITCH, PADLOCKABLE IN THE "ON" AND "DOOR-CLOSED" POSITIONS SHALL BE PROVIDED PRIOR TO THE CONTROL PANEL, IN SERIES CONNECTION CONFIGURATION. MIN. 100 AMP SQUARE D TYPE HU 363 DS, SERVICE ENTRANCE RATED. ELECTRIC SERVICE SUPPLY SHALL BE A MINIMUM OF 100 AMPS.
6	1	UPS CONTROL PANEL: LOCATION OF UPS CONTROL PANEL SHALL CONFORM WITH THE LAYOUT AND ORIENTATION SHOWN WITHIN THIS PLAN SET AND THE UPS PANEL SHALL PROVIDE: <ol style="list-style-type: none"> 1. UNINTERRUPTIBLE POWER SUPPLY (APC BR1500). 2. COOLING FAN WITH THERMOSTAT. 3. FUSE. 4. 120V RECEPTACLE FOR UPS.

LIFT STATION CONTROL PANEL BACK

N.T.S.



CITY OF VENICE
ENGINEERING DEPARTMENT

401 WEST VENICE AVE.
VENICE FL 34285
(941) 486-2626
FAX (941) 480-3031

UTILITIES - LIFT STATION

**CONTROL
PANEL BACK**

DATE
JAN. 2018

SHEET NO.
LS-7

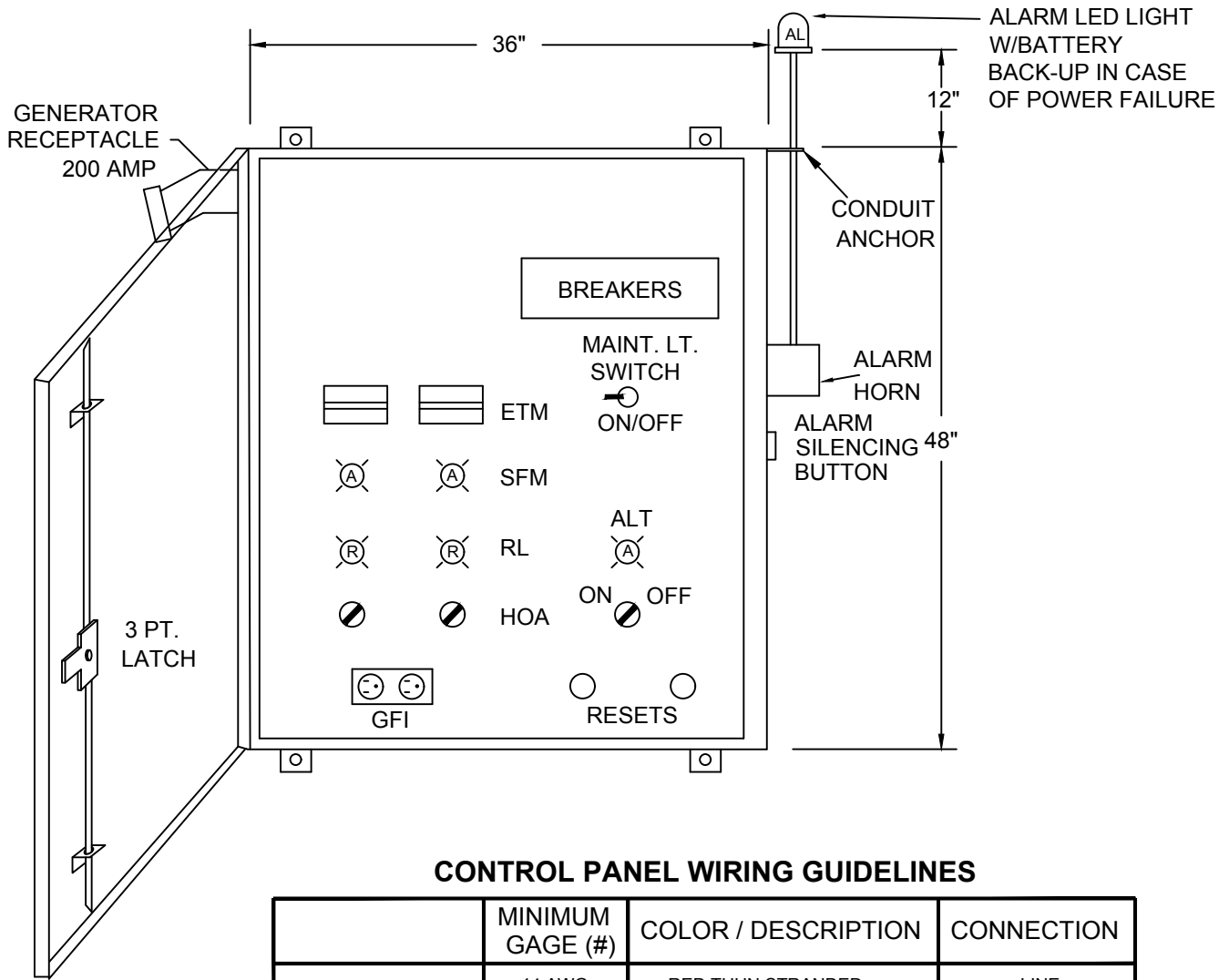

CONTROL PANEL WIRING GUIDELINES

	MINIMUM GAGE (#)	COLOR / DESCRIPTION	CONNECTION
CONTROL CIRCUIT	14 AWG	RED THHN STRANDED	LINE
	14 AWG	WHITE THHN STRANDED	NEUTRAL
	14 AWG	GREEN THHN STRANDED	GROUND
ALARM CIRCUIT	14 AWG	BLUE THHN STRANDED	LINE
	14 AWG	WHITE THHN STRANDED	NEUTRAL
	14 AWG	GREEN THHN STRANDED	GROUND
GFI CIRCUIT	12 AWG	BLACK THHN STRANDED	LINE
	12 AWG	WHITE THHN STRANDED	NEUTRAL
	12 AWG	GREEN THHN STRANDED	GROUND

WIRES MUST BE CLEARLY NUMBERED WITH CONSISTENCY AND LABELED WITH WIRE TAGS IN ACCORDANCE WITH THE WIRING SCHEDULE ABOVE.

ENCLOSURE & DEADFRONT LAYOUT

N.T.S.



CITY OF VENICE
ENGINEERING DEPARTMENT

401 WEST VENICE AVE.
VENICE FL 34285
(941) 486-2626
FAX (941) 480-3031

UTILITIES - LIFT STATION

**ENCLOSURE &
DEADFRONT LAYOUT**

DATE
JAN. 2018

SHEET NO.
LS-8

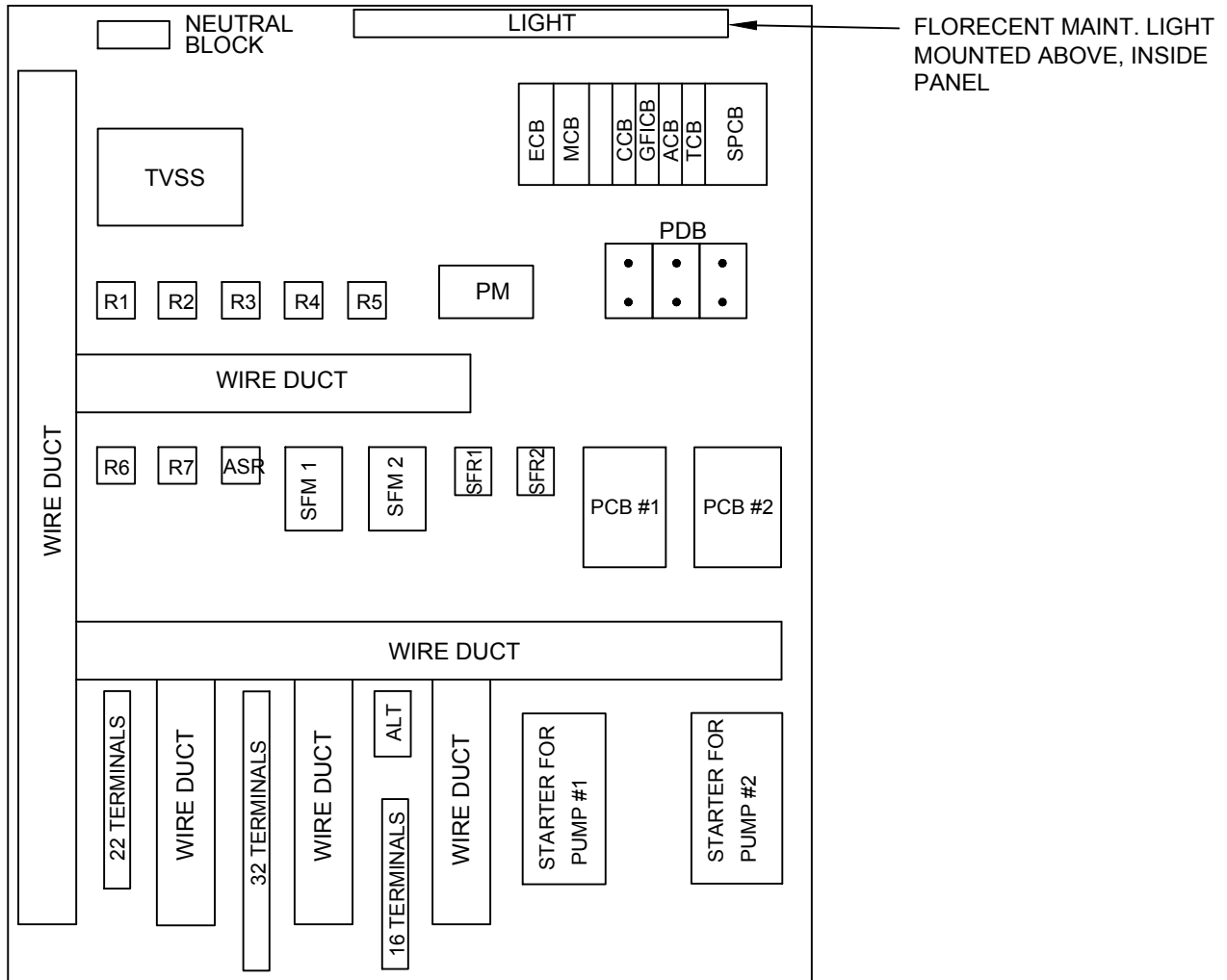

GENERAL ELECTRICAL NOTES

1. ALL POWER DISTRIBUTION, MOTOR CIRCUIT BREAKERS, MOTOR THERMAL UNITS, AND CROSS-LINE STARTERS WILL BE SIZED PER PUMP MANUFACTURER RECOMMENDATIONS AND NEC.
2. MOTOR STARTERS WILL BE SQUARE D CLASS 8536, OPEN FRAME, AND CROSS-LINE WITH A 120 VOLT COIL AND OVERLOAD BLOCKS. MOTOR STARTERS SHALL BE NEMA SIZE 1, AS A MINIMUM.
3. THE DIVERSIFIED ELECTRONICS PHASE AND VOLTAGE MONITOR WILL DE-ENERGIZE THE 120 VOLT AC CONTROL CIRCUIT AND ENERGIZE THE 120 VOLT AC ALARM CIRCUIT UPON PHASE AND VOLTAGE FAILURE. POWER DISTRIBUTION FOR THE ALARM AND CONTROL CIRCUITS WILL BE DISTRIBUTED FROM DIFFERENT 120 VOLT PHASES. THE PHASE MONITOR WILL AUTOMATICALLY RESET VOLTAGE AND PHASE FAILURES TO NORMAL CONDITIONS ONCE A NORMAL CONDITION IS DETECTED.

BACKPLATE LAYOUT

N.T.S.



CITY OF VENICE
ENGINEERING DEPARTMENT

401 WEST VENICE AVE.
VENICE FL 34285
(941) 486-2626
FAX (941) 480-3031

UTILITIES - LIFT STATION

**BACKPLATE
LAYOUT**

DATE
JAN. 2018

SHEET NO.
LS-9

TERMINALS

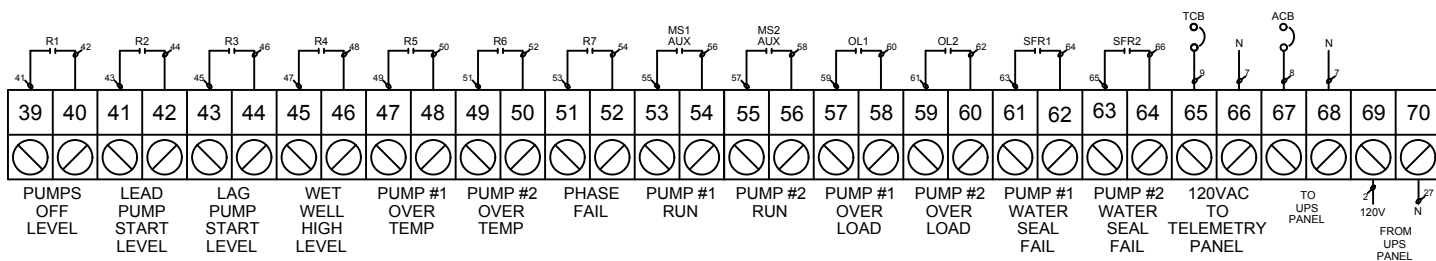
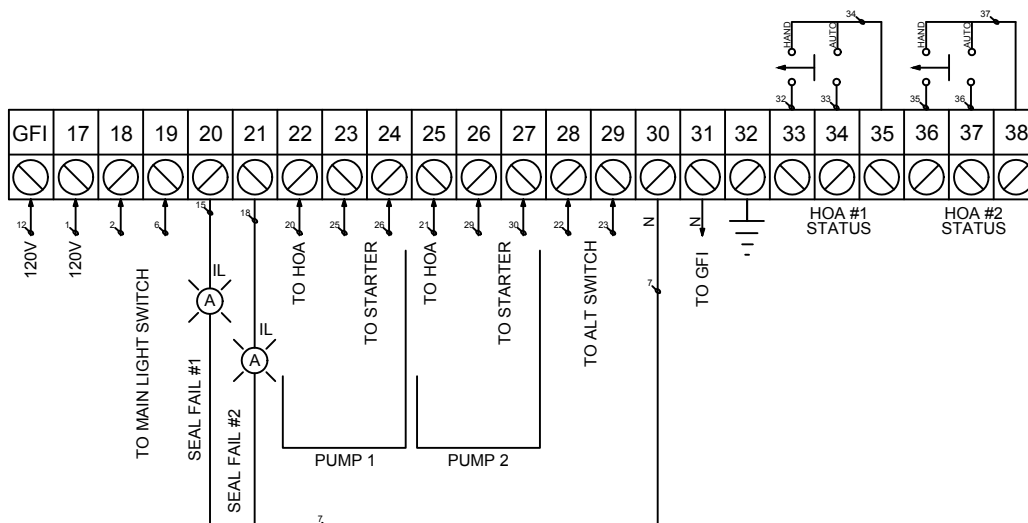
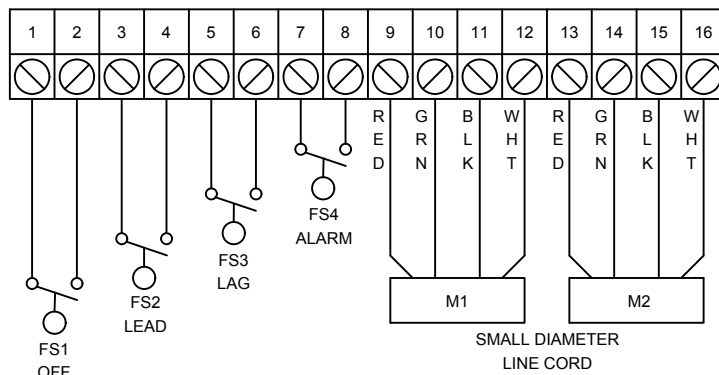

TERMINAL STRIP DIAGRAM

N.T.S.



CITY OF VENICE
ENGINEERING DEPARTMENT

401 WEST VENICE AVE.
VENICE FL 34285
(941) 486-2626
FAX (941) 480-3031

UTILITIES - LIFT STATION

TERMINAL STRIP DIAGRAM

DATE
JAN. 2018

SHEET NO.
LS-10

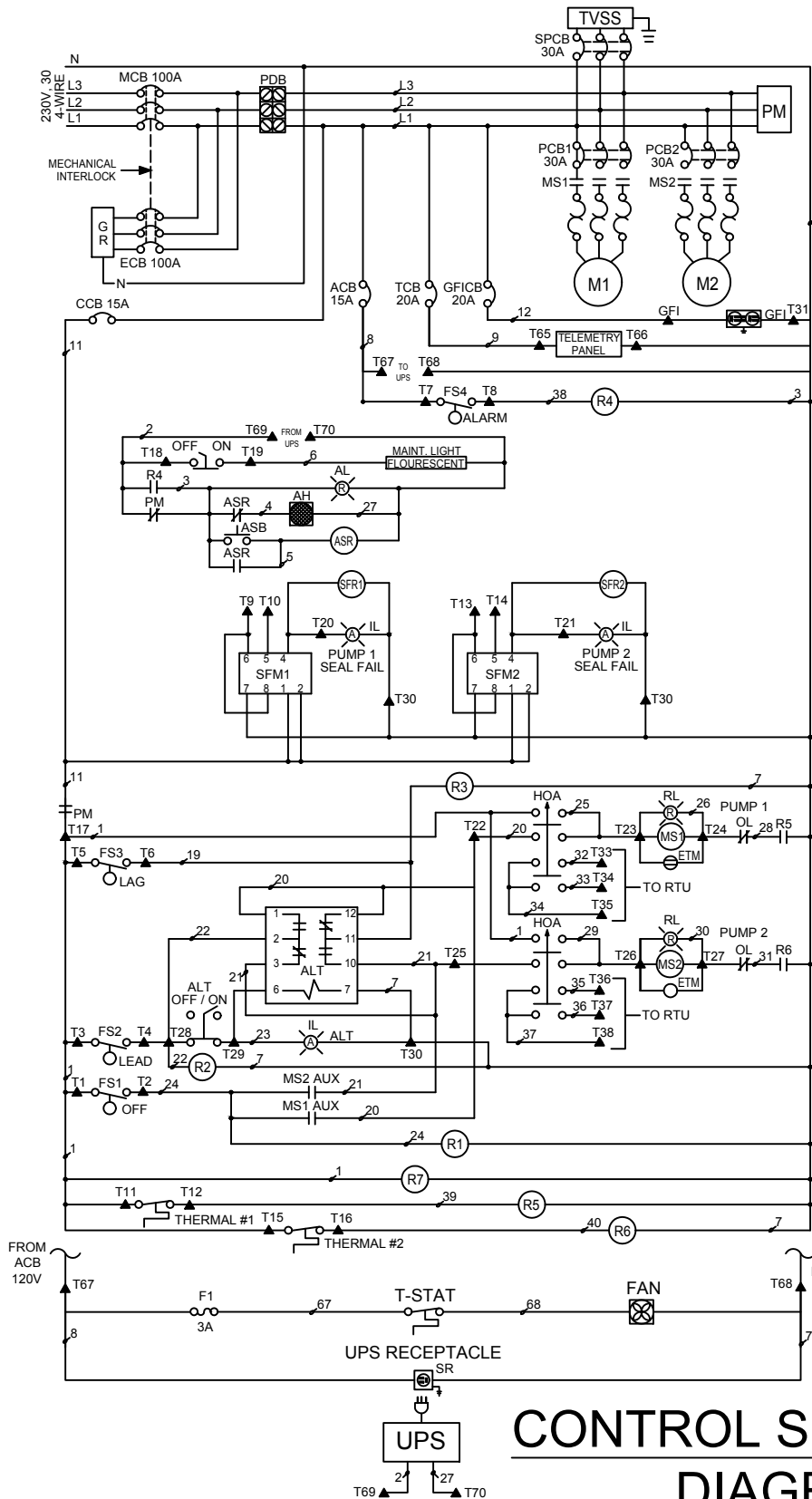

CONTROL SCHEMATIC DIAGRAM

N.T.S.



CITY OF VENICE
ENGINEERING DEPARTMENT

401 WEST VENICE AVE.
VENICE FL 34285
(941) 486-2626
FAX (941) 480-3031

UTILITIES - LIFT STATION

**CONTROL
SCHEMATIC DIAGRAM**

DATE
JAN. 2018

SHEET NO.
LS-11

CONTROL PANEL

BILL OF MATERIALS

QTY.	ABBR.	DESCRIPTION	MANUFACTURER, PART NO.
1	ENC	ENCLOSURE, 304 S.S. NEMA 3R/12	HOFFMAN, A48H3612SSLP (MIN SIZE) W/3PT LATCH
1	MCB	MAIN CIRCUIT BREAKER	SQ.D, QOU3100*
1	ECB	EMERGENCY CIRCUIT BREAKER	SQ.D, QOU3100*
2	PCB1,2	PUMP CIRCUIT BREAKER	SQ.D, QOU330*
1	SPCB	SURGE PROTECTOR CIRCUIT BREAKER	SQ.D, QOU330
1	CCB	CONTROL CIRCUIT BREAKER	SQ.D, QOU115
1	GFICB	GFI CIRCUIT BREAKER	SQ.D, QOU120
1	ACB	ALARM CIRCUIT BREAKER	SQ.D, QOU115
1	TCB	TELEMETRY CIRCUIT BREAKER	SQ.D, QOU120
2	MS1,2	MOTOR STARTER	SQ.D, 8536 (SIZE 1 MIN.)
6	OL	OVERLOAD HEATER	SQ.D, B 28*
1	GR	GENERATOR RECEPTACLE	RUSSELL STOLL, JR SB1044FR
1	PM	PHASE MONITOR	DIVERSIFIED SLA 230ALA**
2	ETM	ELAPSED TIME METER	SIMPSON, 112ET
1	ALT	ALTERNATOR	STRUTHERS-DUNN, A311XBPR
1	AH	ALARM HORN	WHEELLOCK, WHE-31T-115S
1	AL	ALARM LIGHT - STROBE	TOMAR, 495S-120-RED
1	ASR	ALARM SILENCE RELAY	SQ.D, 8501 KP12 V20
1	ASB	ALARM SILENCE BUTTON	SQ.D, 9001 SKR1BH5
1		MAINTENANCE LIGHT SWITCH	SQ.D, 9001 SKS11B5
1		ALTERNATOR SWITCH	SQ.D, 9001 SKS11B5
2	HOA	HAND OFF AUTO SWITCH	SQ.D, 9001 SKS43BH13
2	RL	RUN LIGHT	SQ.D, 9001 SKP1R31
3	IL	INDICATING LIGHT	SQ.D, 9001 SKP1A31
	GFI	GFI RECEPTACLE	HUBBELL, GF20IL
2	SFM1,2	SEAL FAIL MODULE	SSAC, LLC54BA
2	SFR1,2	CONTROL RELAY	SQ.D, 8501 KP12 V20
7	R1 - 7	CONTROL RELAY	SQ.D, 8501 KP12 V20
1	TVSS	SURGE PROTECTOR	INNOVATIVE TECHNOLOGY PTX080 3D101-240-30-N400480-30
1		MAINTENANCE LIGHT (FLOURESCENT)	HOFFMAN, A-LF16M18-R #FS12RC
3		DIN RAIL	ABB, XUS001738

NOTES:

- 1) * = SIZE AS REQUIRED PER HP.
- 2) MIN. #14 AWG THHN
- 3) ** = SIZE AS REQUIRED PER VOLTAGE.



CITY OF VENICE
ENGINEERING DEPARTMENT

401 WEST VENICE AVE.
VENICE FL 34285
(941) 486-2626
FAX (941) 480-3031

UTILITIES - LIFT STATION

**CONTROL PANEL
BILL OF MATERIALS**

DATE
JAN. 2018

SHEET NO.
LS-12

UPS PANEL

BILL OF MATERIALS			
QTY.	ABBR.	DESCRIPTION	MANUFACTURER, PART NO.
1	ENC	ENCLOSURE, 304 S.S. NEMA 3R/12	CUSTOM EQUIPMENT, 24X20X10-SL
1	FAN	COOLING FAN	HOFFMAN, A-4AXFN
1	T-STAT	THERMOSTAT	PFANNENBERG, FLZ530
1	F1	FUSE	FERRAZ, TRM-3
1	SR	UPS RECEPTACLE	PHOENIX CONTACT, 2963860
1	UPS	UNINTERUPTABLE POWER SUPPLY	APC, BR1500

NOTES:

- 1) * = SIZE AS REQUIRED PER HP.
- 2) MIN. #14 AWG THHN
- 3) ** = SIZE AS REQUIRED PER VOLTAGE.

SPARE PARTS

BILL OF MATERIALS			
QTY.	ABBR.	DESCRIPTION	MANUFACTURER, PART NO.
1	MCB	MAIN CIRCUIT BREAKER	SQ.D, QOU3100*
2	PCB1,2	PUMP CIRCUIT BREAKER	SQ.D, QOU330*
2	MS1,2	MOTOR STARTER	SQ.D, 8536 (SIZE 1 MIN.)
1	PM	PHASE MONITOR	DIVERSIFIED SLA 230ALA**
1	TVSS	SURGE PROTECTOR	INNOVATIVE TECHNOLOGY PTX080 3D101-240-30-N400480-30
1		PUMP	HYDROMATIC OR ABS, PER SPECS
1		IMPELLOR	316 STAINLESS STEEL, PER SPECS
1		WEAR RING	PER SPECS
1		FLOAT LEVEL SWITCHES (1 SET)	ANCHOR SCIENTIFIC INC., PER SPECS



CITY OF VENICE
ENGINEERING DEPARTMENT

401 WEST VENICE AVE.
VENICE FL 34285
(941) 486-2626
FAX (941) 480-3031

UTILITIES - LIFT STATION

**UPS PANEL &
SPARE PARTS LIST**

DATE
JAN. 2018

SHEET NO.
LS-13